

Mitsubishi Electric Air-conditioner Network System Maintenance Tool

– Advanced –
for .NET
Operating Manual

Contents		Page
1	Foreword	
	1.1 Introduction of Maintenance Tool	1
	1.2 Required Operating Environment	7
	1.3 Installation	8
	1.4 Starting and Ending the Application	14
2	Terms for Each Section	
	2.1 Design of Screen	33
	2.2 Operating Method	33
3	On-Line Monitor Operation Method	
	3.1 On-Line Monitor Screen Transfer	34
	3.2 Function Chart	35
	3.3 Address Search Method	37
	3.4 Main Screen	39
	3.5 Function Selection Operations	42
	3.6 Display Mode Change	42
	3.7 Connecting Information	43
	3.8 Operation Monitor	46
	3.9 Optional Setting	75
	3.10 Operation Control	85
	3.11 Maintenance Data	93
	3.12 OC Date / Time Setting	112
	3.13 Free contact of indoor unit	113
	3.14 Remote error notification	115
	3.15 Setting and Monitoring DIDO/AI/PI Controllers	142
	3.16 Setting the Values for Indoor unit Functions	179
	3.17 Compressor operating data monitor	181
	3.18 Initial Settings and Monitoring AHC ADAPTER	185
	3.19 Fixed value setting of compressor frequency	208
	3.20 Indoor unit LEV problem detection support	210
	3.21 Detection of the incorrect port connections/settings	221
4	Off-Line Monitor Operating Method	
	4.1 Off-Line Monitor Screen Transfer	236
	4.2 Function Chart	237
	4.3 Operation Monitor	239
	4.4 System Information	243
	4.5 Monitoring of Pre-error Data	244
	4.6 Compressor operating data monitor	245
	4.7 Function common for each screen	246
	4.8 Offline Analyze on Wide area access mode	251
	4.9 Offline Analyze on Initial settings of AHC	252
5	File Names	253
6	Troubleshooting	259
7	Explanation of Terminology	267
8	Connection table for M-series	435
9	Trademark and license	464

Before using Maintenance Tool, read this manual thoroughly to ensures correct operation.

1.1 Introduction of Maintenance Tool

The Maintenance Tool are comprised of the **On-Line Monitor** and the **Off-Line Monitor**.

The following four connection methods are available in the Online Monitoring.

- (1) Monitoring by connecting the maintenance tool to MN converter (CMS-MNF,CMS-MNF-B,CMS-MNG-E) via RS-232C.
- (2) Monitoring by connecting the maintenance tool to MN converter (CMS-MNG-E) via USB.
- (3) Monitoring through the Centralized Controller by connecting the maintenance tool to LAN. A brief explanation of each of their function is provided here.Maintenance Tool is connectable to Centralized Controllers and Remote Monitoring Controllers(CMS-RMD) via the LAN.
- (4) Monitoring by connecting the maintenance tool to USB via USB/Serial conversion cable for P/M series which is not connected to M-NET.

* "G(B)-50A / GB-24A / AG-150A / GB-50ADA / PAC-YG50ECA / EB-50GU / AE-200 / AE-50 / EW-50 / PAC-YG50ECA" is referred to as "Centralized Controller".

* "G(B)-50A Web / GB-24A Web / AG-150A Web / GB-50ADA Web / EB-50GU Web / AE-200 Web / AE-50 Web / EW-50 Web" is referred to as "Centralized Controller Web".

To use the maintenance tool via Centralized Controller(Network), license registration for the Centralized Controller to be used is necessary.

Purchasing the license No. for each Centralized Controller be used, conduct the license registration through the Web browser ([http://\[IP address of the Centralized Controller\]/ administrator.html](http://[IP address of the Centralized Controller]/ administrator.html)). After selecting "Maintenance tool" of the optional function on the Web Browser Screen displayed, enter the purchased license No.

Refer to the following chapters in the "Web Browser Operation Manual" for detailed information about license registration.

Centralized Controller G-50A, AG-150A or GB-50ADA:Chapter4 [Registering a License for Optional Functions]

Centralized Controller EB-50GU, AE-200, AE-50 or EW-50:Chapter10 [License registration for optional functions]

When connecting maintenance tool via Expansion Controller,register the license in AG-150A connected by the Expansion Controller. (Only when AG-150A that registers the license is normally connected, it is possible to connect via Expansion Controller.)

Important:

Only one Maintenance Tool can be connected to each M-NET centralized control system.

If more than one Maintenance Tool is connected to a system, communication error (Error codes 6603 or 6608) may occur with the air-conditioning and refrigeration equipment or with the centralized controller due to increased communication traffic.

1.1.1 On-Line Monitor(via MN converter)

The **On-Line Monitor** is connected to the unit by a MN Converter (CMS-MNF,CMS-MNF-B,CMS-MNG-E) and can monitor such areas as system data, unit data and operating data.

(1) In case for local connection (via RS-232C)

Connecting PC installed with the maintenance tool to M-NET transmission line via MN Converter allows conducting various monitoring and setting from the Maintenance Tool.

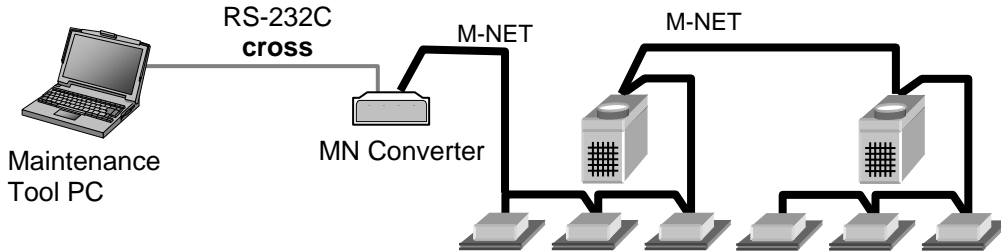

NOTE:

- When the MN Converter (CMS-MNG-E) is being used in Remote Error Notification mode (see section 3.13), you cannot connect to the MN Converter (CMS-MNG-E) via RS-232C. Connect via USB.

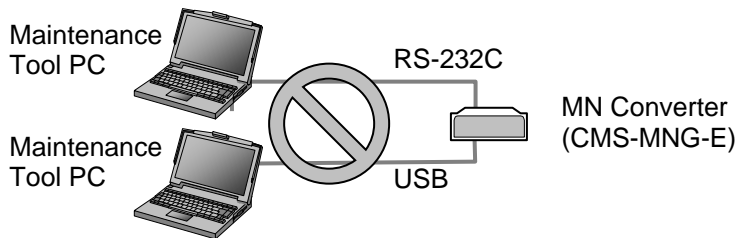

NOTE:

- You cannot connect to the MN Converter (CMS-MNG-E) via RS-232C and USB at the same time. Doing so may result in malfunctions.

(2) In case for local connection (via USB) (CMS-MNG-E)

Connecting PC installed with the Maintenance Tool to M-NET transmission line via MN Converter allows conducting various monitoring and setting from the Maintenance Tool.

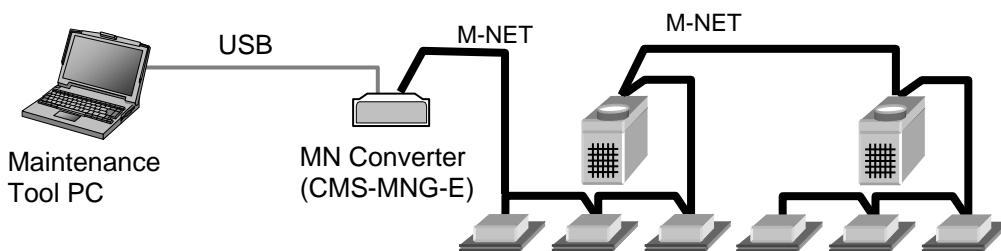

NOTE:

- To connect to the MN Converter via USB, the USB serial driver must be installed on the Maintenance Tool PC. [Refer to 1.3.4]

NOTE:

- You cannot connect to the MN Converter (CMS-MNG-E) via RS-232C and USB at the same time. Doing so may result in malfunctions.

(3) In case for remote connection

Using a modem and remotely connecting PC installed with the Maintenance Tool to MN Converter via public telephone circuit allow conducting various monitoring and setting as same in the case of local connection.

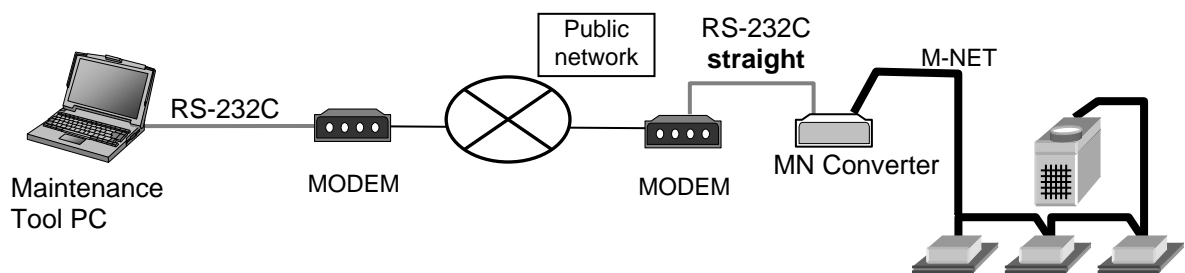

*For the remote connection utilizing MN Converter, an isolator is required to be inserted between the modem and MN Converter.(except CMS-MNG-E)

For detail, please see Installation Manual-annexing of MN Converter (CMS-MNF-B).

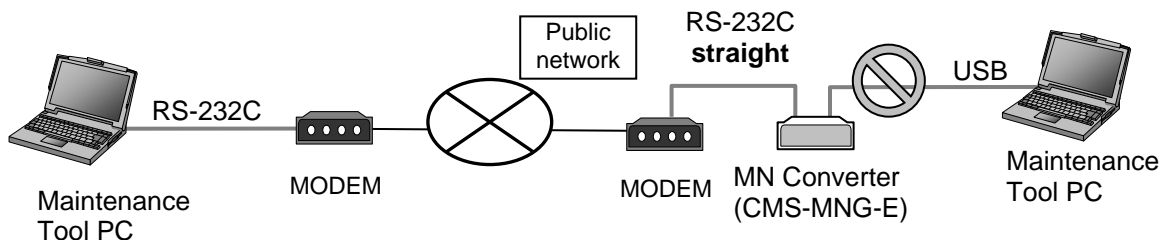

NOTE:

- You cannot use the Maintenance Tool via RS-232C remote connection and via USB at the same time. Doing so may result in malfunctions. You can use the Maintenance Tool for error notification setting via USB when the Maintenance Tool is not used via RS-232C remote connection. (Used when connecting via MN converter CMS-MNG-E.)

1.1.2 On-Line Monitor(via Centralized Controller)

The **On-Line Monitor** is connected to the unit by the Centralized Controller and can monitor areas as system data, unit data and operating data.

NOTE:

- When connecting AG-150A with Expansion Controller(PAC-YG50ECA), connect maintenance tool not AG-150A but via Expansion Controller.
- AG-150A Ver2.45 or more and Expansion Controller Ver1.45 or more are necessary for the connection via Expansion Controller.

(1) In case for local connection

By directly connecting the PC installed with Maintenance Tool and Centralized Controller through LAN, various monitoring/setting can be performed from the Maintenance Tool.

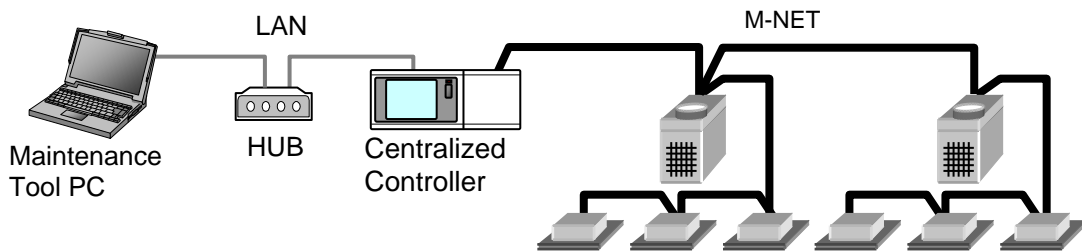

(1)-2 In case for local connection for AG-150A connection with the Expansion Controller (PAC-YG50ECA)

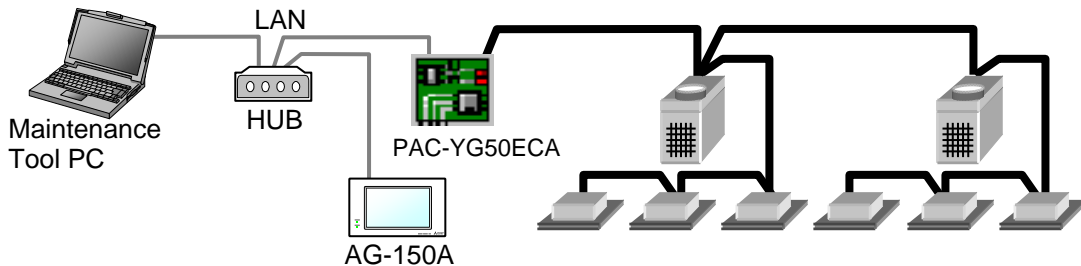

(2)-1 In case for remote connection (Dialup connection mode)

By connecting the PC installed with Maintenance Tool and Centralized Controller through public network remotely, various monitoring/setting can be performed from the Maintenance Tool.

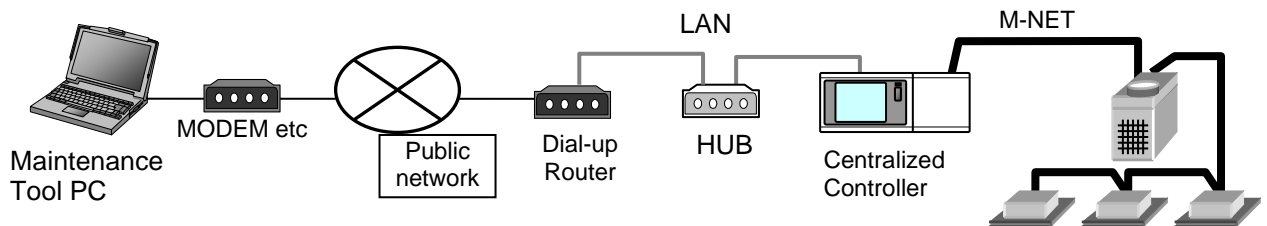

1.1.3 On-Line Monitor(via USB/Serial conversion cable) for M or P-series

The On-Line Monitor is connected to the unit by the USB/Serial conversion cable and it can monitor unit data and operating data.

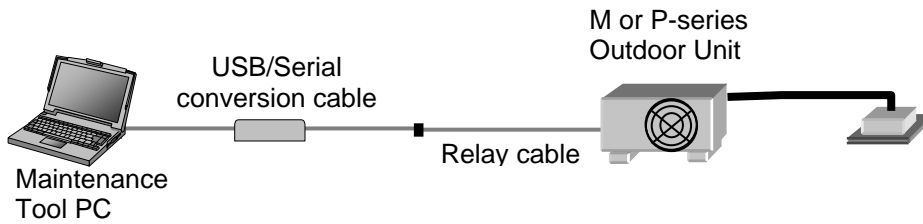

<Connectable Models and Relay cable correspondence table>

Connectable Models		Relay cable type	Connection point of Outdoor unit
P-series	PUY/PUZ etc	Type P	CNMNT
M-series *1	MXZ-2~6 without Branch Box	Type AD/B/C *2	CN605/606/806/861 *2
	MUY/MUZ/MUFZ		
	SUZ/SUHZ		

*1 Please refer to chapter 9 for detailed applicable models.

*2 Relay cable and Connection point are different to each model. [Refer to chapter 9]

NOTE:

- To connect to the USB/Serial conversion cable via USB, the USB serial driver must be installed on the Maintenance Tool PC. [Refer to 1.3.4.2]

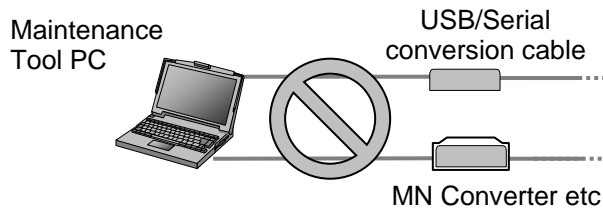

NOTE:

- You cannot use the Maintenance Tool via MN converter/Modem/HUB and USB/Serial conversion cable at the same time.

1.1.4 Off-Line Monitor

The **Off-Line Monitor** can display, print information obtained by the On-Line Monitor.

In the case of connection monitoring utilizing Centralized Controller, the operation monitor data collected by Centralized Controller will be transmitted to remote mail servers periodically if the [Operation monitor - mail communication mode] of online mode is adapted.

Using this function allows to collect and monitor the operation monitor data without continually connecting the maintenance tool.

*For the setting of the [Operation monitor - mail communication mode], refer to 3.7.1 and 4.3.2 description.

*Image of the [Operation monitor - mail communication mode]

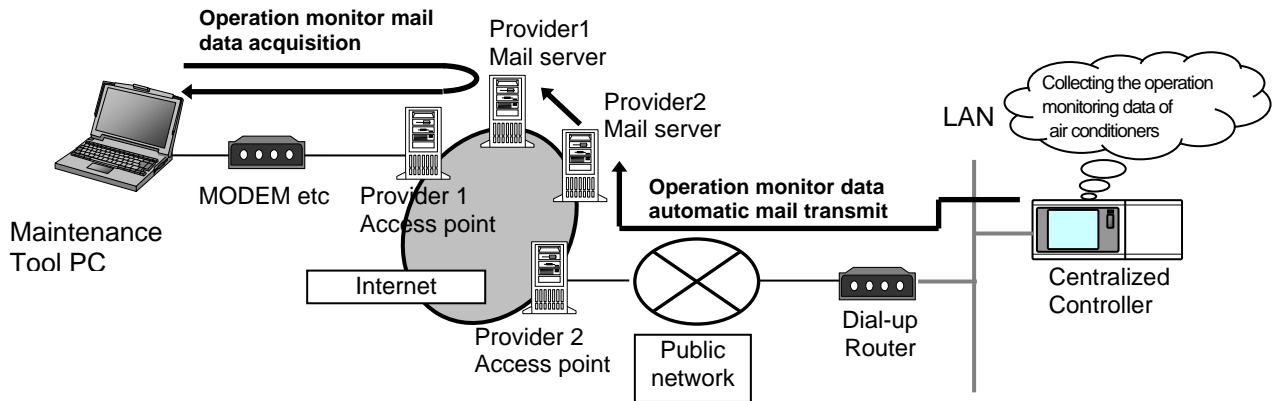

1.1.5 Wide area access mode

Under the "Wide area access mode," the access method for remote connection can be registered to the database of each customer enabling easy online connection with the air conditioning system of the customer desired to be accessed.

[Remote access method]

- **LAN** : Accessing by directly connecting Maintenance Tool PC and Centralized Controller with LAN (WAN).
- **Dialup** : Accessing by dialup connection to Centralized Controller via public network.
- **E-mail** : Accessing by E-mail communication to Centralized Controller via mail server.
- **Modem (MN Converter)** : Accessing by connecting Modem to MN Converter via public telephone circuit.

After the online connection performed by any of the above methods, you may use the similar function as that obtainable in the normal online connection.

While under the offline mode, customer information will be provided to the monitored data enabling only to select a specified customer for display.

1.2 Required Operating Environment

1.2.1 Hardware Requirements

- OS Windows 8.1/10/11
(Recommended English version *1)
- CPU 2GHz or faster
- RAM 4GB or more(at least 8GB recommended)
- HDD Available space 100GB or more *2
- LCD Screen resolution:1024x768 or more
- Operating environmentNET Framework 4.6.2 or later
- Serial port 1 RS232C serial port (Used when connecting via MN converter)
- USB port 1 USB port (Used when connecting via MN converter CMS-MNG-E) *3
- Pointing device..... Mouse or track ball or any other pointing device

*1 About OS

Fundamentally, it corresponds to OS of each country. However, separators of time and date differ in each language. This separator may affect a maintenance tool.

It recommends using it by English OS and Regional options setup, changing into English area form. Or it recommends using it, changing date separator into [/] and time separator into [:].

*2 About Hard Disk Space

The hard disk space recommended above is only the amount required for installing the maintenance application. Additional space will be required if the operating data is also to be stored on the hard disk. Accordingly, there may not be enough memory to store operating data if the maintenance system is installed in a computer with limited hard disk memory.

*3 About USB port

USB port of MN Converter (CMS-MNG-E) and USB/Serial conversion cable are USB1.1.

NOTE:

TG-2000A and Maintenance Tool cannot operate with the same personal computer.

1.2.2 Required Materials

The following materials are needed for operating the Maintenance Tool :

(1) In case of routing via MN converter

MN Converter (CMS-MNF,CMS-MNF-B,CMS-MNG-E), Personal Computer, RS-232C **cross** cable, USB cable(CMS-MNG-E) and modem in the case of remote connection, are required. RS-232C is to be **straight** cable in this case.

For detail, please see Installation Manual-annexing of MN Converter.

(2) In case of routing via Centralized Controller

Centralized Controller, personal computer, LAN cable (Straight) and HUB.

A dial-up router is required for remote communication. For the dial-up router to be used, employ that allowing data communication by receiving external telephone transmission.

(3) In case of routing via USB/Serial conversion cable.

USB/Serial conversion cable and Relay cable 【Service parts No: M21 EC0 397】 , and Personal Computer.

1.3 Installation

Ver5.** is not an upgrade, but a totally new version.

* Ver5.00 & Ver4.** can both be installed on the same PC

* The data of Ver4.** can be exported & then imported into Ver5.**
However, Ver5.** data can't be used in Ver4.**.

Caution:

Please refer to also 1.3.3 Change of computer name on PC.

1.3.1 Setting Up the Maintenance Tool (New setup)

Caution:

- Administrative ID and password are required to set up the Maintenance Tool.
 - After the setup is complete, the administrative ID or password is not required to use the Maintenance Tool.
- Before setting up, please confirm the following points.
 - The check 'Compress drive to save disk space' of LocalDisk(C:) Properties must be removed. When not satisfying it, the error occurs when installing it and the installation is discontinued.

(1) Starting the setup program

Execute "**Setup.exe**" located in folder (Its name is "New") on CD-ROM. (**Not click on any other files.**)

Double clicking on "**Setup.exe**" with the explorer displays the application install screen.

NOTE:

- The number of applications installed by the OS is different, but just click on [**install**] button. (Right Figure is Screen of Windows 8.1.)



Caution:

- It takes 1 minutes to install the application.

(2) Installing the Maintenance Tool

When the installation of the application software is finished, the installation screen of the Maintenance Tool is displayed. Confirm the display contents, and if no problem was found on the content, click **[Next]** button.

* To stop setting up, click on **[Cancel]** button.



(3) Ready to the installation start

Confirm the starting and select an **[Install]** button. Click on [Install] button starts installation.

* Clicking on **[Cancel]** button stops installation.

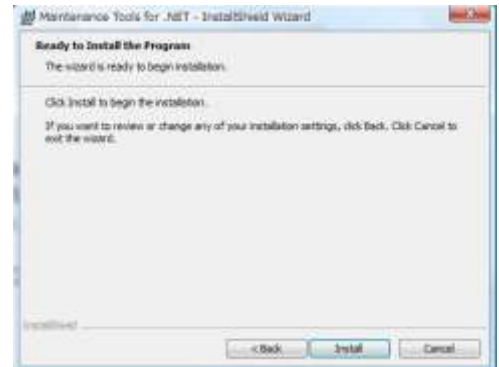

Caution:

- When a screen such as the right figure was displayed without installation start preparations screen being displayed, Select **[Remove]**, and please click a **[Next]** button.

- Click **[Remove]** with the next screen, click on **[Finish]**, and be completed.

- Install the Maintenance Tool program.

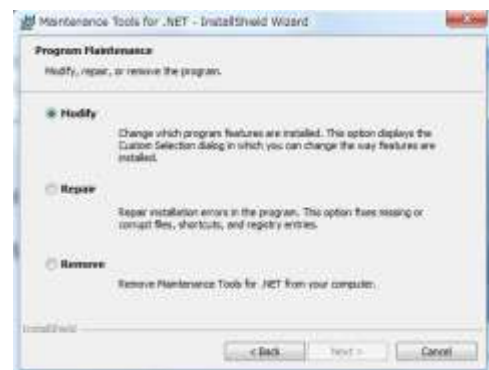

(4) Confirming the completion of Maintenance Tool setup

1) Select [**Finish**] button.

Click on [**Finish**] button on the Installation Complete screen.

Now the installation of the Maintenance Tool is complete.



After completing installation, restart your computer.

Store the CD-ROM in a safe place.

Caution:

After installing Maintenance Tool, be sure to restart your computer.

(5) Setting up other software (Only using USB/Serial conversion cable)

When connecting to M / P-series via USB / Serial Conversion cable, you need to install the following software additionally.

1) Install rewriting software for USB/Serial conversion cable

Install the rewriting software (FT_PROG) from the following FTDI site.

<http://www.ftdichip.com/Support/Utilities.htm>

NOTE:

•The operation of FT_PROG requires Microsoft .NET Framework version 4.0 or later.

2) Install Microsoft Visual C++ Redistributable for Visual Studio 2015

Install the Microsoft Visual C++ Redistributable for Visual Studio 2015 from the following Microsoft site.

<https://www.microsoft.com/en-US/download/details.aspx?id=48145>

NOTE:

•Even for 64bit PC ,you need to install 32bit software (vc_redist.x86.exe).

3) Install USB driver

For the install method, refer to 1.3.4.2 “For USB/Serial conversion cable”.

1.3.2 Uninstalling the Maintenance Tool

It explains the method of uninstalling the Maintenance Tool as follows.

[In the case of Windows8.1]

- (1) Confirm the ending of **Maintenance Tool**.
Confirm that Maintenance Tool program has been ended.
If not, end the program.
***For the ending method, refer to Chapter 1.4.7.**

- (2) Open [Uninstall a program]
 - (a) By using a mouse
Place the mouse pointer in the top or bottom right corner of the screen to access the Charm Bar.
Click [Settings] on the Charm Bar, click [Control Panel], and then click [Uninstall a program]
 - (b) From the touch panel
Swipe the screen from the right edge to access the Charm Bar.
Tap [Settings] on the Charm Bar, tap [Control Panel], and then tap [Uninstall a program]



- (3) Select [Maintenance Tool for .NET]
Select [Maintenance Tool for .NET] from a list of applications that appears, and delete [Maintenance Tool for .NET]

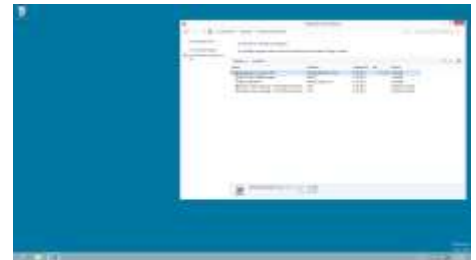

- (4) Exit [Uninstall a program].
When done deleting the program, exit the [Uninstall a program] window.

NOTE:

- Recommend not to delete the common components.
- There are folders and files that can not be deleted with this uninstalling.
(Example:C:\MnttoolNetEA)
- If you do not need the installed software to use USB / Serial conversion cable, please uninstall it.
Please refer to each software manual for the uninstallation method.

Caution:

- After uninstalling Maintenance Tool program, be sure to restart your computer.

[In the case of Windows10,11]

(1) Confirm the ending of **Maintenance Tool**.
 Confirm that Maintenance Tool program has been ended.If not, end the program.
***For the ending method, refer to Chapter 1.4.7.**

(2) Open [Control Panel]
 Click the [search box] from the taskbar. Then start typing “control panel” and click the “Control Panel” search result.

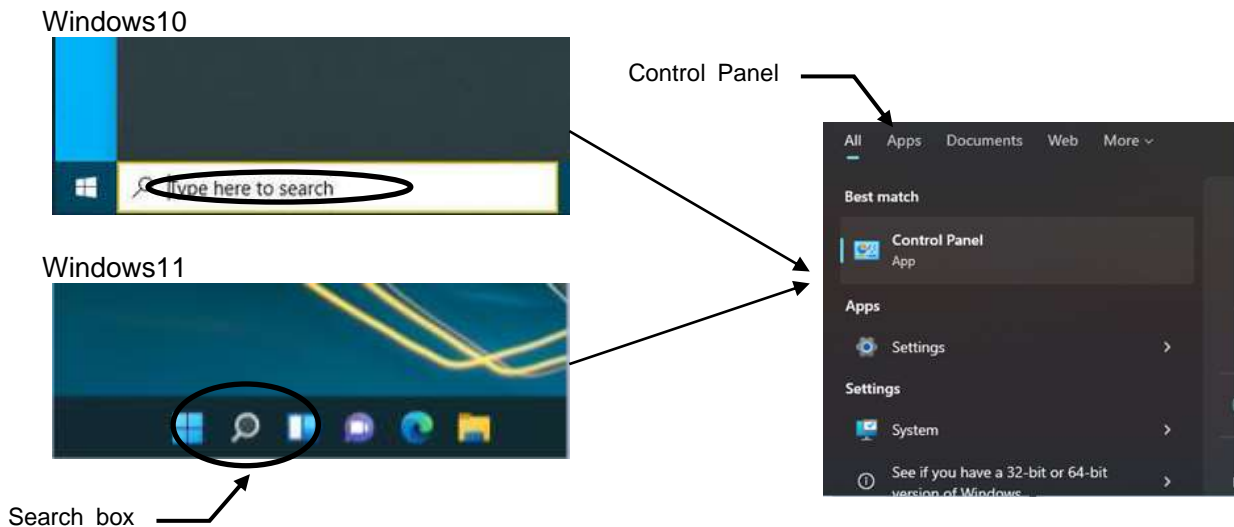

(3) Open [Uninstall a program]
 The [Control Panel] window will appear.Click [Uninstall a program]



(4) Select [Maintenance Tool for .NET]
 Select [Maintenance Tool for .NET] from a list of applications that appears, and delete [Maintenance Tool for .NET]



(5) Exit [Uninstall a program].
 When done deleting the program, exit the [Uninstall a program] window.

NOTE:

- Recommend not to delete the common components.
- There are folders and files that can not be deleted with this uninstalling.
 (Example:C:\MnttoolNetEA)
- If you do not need the installed software to use USB / Serial conversion cable, please uninstall it.
 Please refer to each software manual for the uninstallation method.

1.3.3 Change of computer name on PC

Do not change the computer name after the Maintenance Tool has been setup. Maintenance Tool will not run properly if changed, and may require the OS to be installed again.

1.3.4 USB Serial driver installation

1.3.4.1 For MN Converter

To connect the Maintenance Tool to the MN Converter (CMS-MNG-E) via USB and then use the tool, the USB serial driver must be installed on the Maintenance Tool PC.

- (1) Execute the batch file in the respective folder that corresponds to the OS of your PC. (See the table below.)

	Windows8.1	Windows10,11
Driver folder	CMS-MNG_Driver (win8_x86_x64)	CMS-MNG_Driver (win10_x86_x64)
Driver file	Win8DriverInst.bat	Win10DriverInst.bat

- (2) Connect a USB cable to the USB port of the MN Converter (CMS-MNG-E).

This completes USB serial driver (CMS-MNG) installation.
Check that the driver is running correctly in the Device Manager window.

1.3.4.2 For USB/Serial conversion cable

To connect the Maintenance Tool to the USB/Serial conversion cable via USB and then use the tool, the USB serial driver must be installed on the Maintenance Tool PC.

- (1) Install the latest USB driver (D2XX) from the following FTDI site.

<http://www.ftdichip.com/Drivers/Ds2XX.htm>

- Please connect USB/Serial conversion cable and install from Device Manager window etc.
- Check that the driver is running correctly in the Device Manager window.

1.4 Starting and Ending the Application

1.4.1 Starting the Maintenance Tool

- (1) Connect the computer and Centralized Controller and air conditioner.
* When using the USB / serial conversion cable, please do not connect it to the air conditioner side yet.
- (2) Click on "**Start**", and then click on "**Programs**".
- (3) Click on "**Maintenance Tool for .NET**" in the "**Maintenance Tool**" folder.



- (4) The **Title Screen** will soon appear.



- (5) The "**Screen Display Setting**" screen is displayed.
Setting the display settings

a) Display scale

The Maintenance Tool screen will appear smaller on a high-resolution monitor.
If the Maintenance Tool screen appears too small, check "Enable auto scaling."

b) [This window is not displayed,when starting Maintenance tool.]

If the checkbox is checked, this window will not appear when the Maintenance Tool is starting up.

c) [OK]

Click [OK] to close the "Screen Display setting screen."

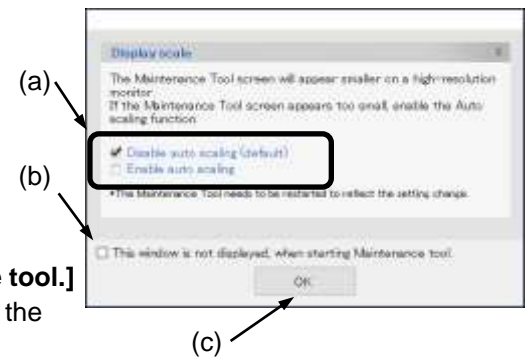

Note

- The Maintenance Tool needs to be restarted to reflect the change in the display scale setting.
- The display scale setting function is available only on Windows10,11.

(6) The “**Select units of measurement**” screen is displayed.
 Select the method of displaying the Temperature, the Pressure and the capacity.

a) Temperature

- If the “**Degrees Celsius**” is checked, the temperature display becomes a celsius.
- If the “**Degrees Fahrenheit**” is checked, the temperature display becomes a fahrenheit.

b) Pressure

- If the “**Kilogram/cm2**” is checked, the pressure display becomes a Kilogram/cm2.
- If the “**Pound/inch2**” is checked, the pressure display becomes a Pound/inch2.

c) Capacity

- If the “**Capacity Code**” is checked.
 - The capacity item name of the Unit Information Display Columns becomes “**Capacity**”, and **indoor unit capacity code** is displayed.
 - The QJ item name of the operation monitor becomes “**QJ**”, and **indoor unit capacity code** is displayed.
- If the “**UL-Model Number**” is checked.
 - The capacity item name of the Unit Information Display Columns becomes “**UL-Model**”, and indoor unit **UL-Model number** is displayed.
 - The QJ item name of the operation monitor becomes “**Model**”, and indoor unit **UL-Model number** is displayed.

d) Model

- If the “**Mitsubishi Model**” is checked
 - Mitsubishi model name will be displayed in the “Model” field on the “Main Screen”. [Refer to 3.4 Main Screen.]
- If the “**IR Model**” is checked
 - IR model name will be displayed in the “Model” field on the “Main Screen”. [Refer to 3.4 Main Screen.]
 - IR model means product released from Ingersoll Rand brand in the United States.

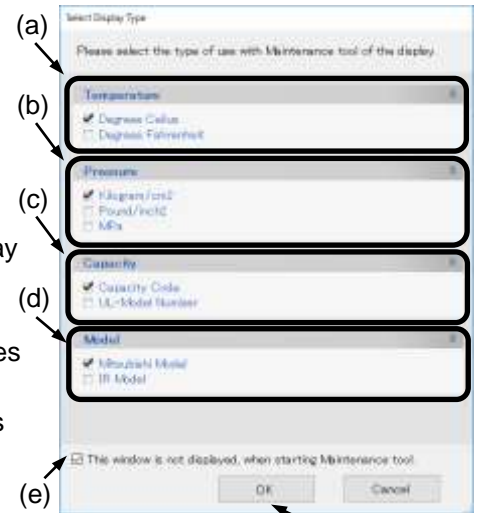

Caution:

The “Model” setting applies only to the “PQRY-TLMU”, “PQRY-YLMU”, “PQHY-TLMU”, “PQHY-YLMU”, “PUMY”, “AE-200-A”, “TE-50A”, “TW-50A”, and “PWFY” models.
 For other models, the name printed on the nameplate will be displayed on the Main Screen regardless of this setting.

e) If the “**Don’t show this window again.**” Is checked, this window will not appear again.

(However, it is possible to select it from “**Select Monitor Mode**” screen.)

f) If the button selected, this screen is closed.

*The capacity to store the data obtained by the maintenance tool counts for 2G-bite maximum. When the remaining storage capacity is insufficient at starting, Warning Screen will appear. In this case, move to OFF- Line Screen to delete unnecessary data.



(7) Thereafter, the selection screen of Monitor mode is displayed.
 Selecting the mode to be adapted.

Normal mode

a) ON LINE MODE

- MN CONVERTER

When on-line monitoring is adapted to air conditioning system by connecting MN Converter [Refer to 1.4.2.1.]
 Further select Remote connection to conduct remote connection. [Refer to 1.4.2.2.]

- Centralized Controller (LAN)

When on-line monitoring is adapted to air conditioning system via Centralized Controller by connecting the Maintenance Tool to LAN. [Refer to 1.4.4.1.]
 For remote connection, select either "Dialup connection mode" or "E-mail connection mode". [Refer to 1.4.4.2., 1.4.4.3.]

- USB/Serial conversion cable

When on-line monitoring is adapted to air conditioning system by connecting USB/Serial conversion cable [Refer to 1.4.3.1.]

b) OFF LINE MODE

- Offline analysis

When offline analysis is adapted to the data collected under ON-LINE MODE [Refer to 1.4.5.]

c) Wide Area Access

- Online Connection

When monitoring on-line, using various connection methods [Refer to 1.4.6.1.]

- Offline Analyze

When offline analysis is adapted to the data collected under ON-LINE MODE [Refer to 1.4.6.2]

d) When [Initial Setting] is selected, the "Initial Setting" screen is displayed.

When [Screen Display] is selected, the "Screen Display Setting" screen is displayed.

[Refer to (5)]

When [Unit of Measurement] is selected, the "Select units of measurement" screen is displayed.

[Refer to (6)]

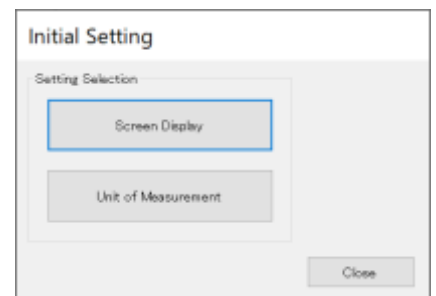
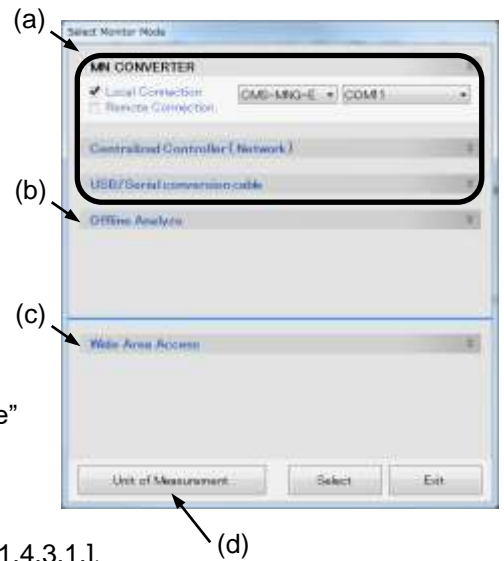

NOTE:

• [Remote Connection], [Centralized Controller(LAN)], [USB/Serial conversion cable] of [MN CONVERTER] will not be available for selection by non-administrative users.

1.4.2 Starting the On-Line Monitor(MN Converter connection)

1.4.2.1 In case for local connection

This will be used when online monitoring is adapted to air conditioning system by connecting the maintenance tool and MN Converter locally. The maintenance tool, MN Converter and air conditioning system should be connected beforehand.

- (1) Clicking "MN CONVERTER" on the selection screen of Monitor mode selects "Local connection" simultaneously. Select the model name of the connected MN Converter and the COM port No. of the connected RS-232C. Last click  .

* When MN Converter model is "CMS-MNG-E", and it is connected via USB, USB COM port No. is displayed. Select the USB COM port No. of the connected USB.



1.4.2.2 In case for remote connection

This will be used when online monitoring is adapted to air conditioning system by using a modem, and connecting the maintenance tool and MN Converter with public telephone circuit remotely. The setting up of the modem for Windows (modem at the remote site side) and the initial setting up (modem connecting MN Converter at the local side. For detail, refer to (3).) are previously required. The connection of the modem, public telephone circuit and local MN Converter is necessary.

- * For a description of the on-site air conditioner system connection method, refer to the MN Converter Operation Manual.
- * If communication does not have for 10 minutes in remote connection, "Timeout occurred!" will be displayed, if O.K. is pushed, a telephone circuit will be cut automatically and the Maintenance tool will be ended.

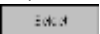
- (1) After clicking "MN CONVERTER" on the selection screen of Monitor mode, and click "REMOTE CONNECTION." For MN Converter, "CMS-MNF-B", "CMS-MNG-E" will automatically be selected. Then select COM port No. of RS-232C connected with equipment (like a modem) for connection to public telephone line. Last click  .

*MN Converter to be locally installed should be „CMS-MNF-B“, "CMS-MNG-E".
Remote connection can not be performed with "CMS-MNF."

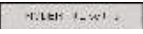
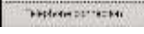

- (2) Next the screen to set remote connection will appear. In order to conduct the initial setting (AT command setting) of the modem to be used, click  , and to initiate remote connection, click  .

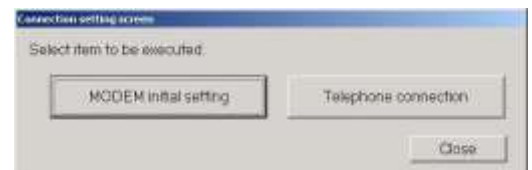

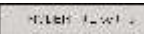
*Insert an isolator between the local MN Converter and modem for insulation. Inserting the isolator reduces the number of lines used by the internal wiring of RS-323C. For this reason, it is required to select  before the remote connection to change the setting information on the modem to be installed at the local side. For detail, see Installation Manual-annexing of MN Converter (CMS-MNF).

(3) Initial setting of modem

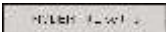
For the modem to be installed at the local side (MN Converter side), initial setting should be applied before connecting remotely. To apply the initial setting of the modem, click  on the remote setting screen.

The **Connection Modem Initial Setting Screen** will appear. A modem that is already initialized does not have to be re-initialized.

The explanation of the operation only is described here. For the detail of the setting content, see Installation Manual-annexing of MN Converter (CMS-MNF).

(a) Explanation of screen

-Select a registered modem setup file at the **Select Initial Settings File Box**. The contents of the selected file will be listed below the selection box.

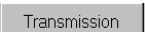
-Click on  and the modem will be set up according to the contents selected at the selection box.

(AT commands are sent to the modem.)

Check if transfer with the modem is normal at the **Transfer with Modem Status Screen**.

- Click on  to initialize another modem. Send the initialize command and register the transfer contents for the modem at the **AT Command Transmit Screen**. [Refer to (b)]

- Click on  to delete the selected modem settings from the registered settings. When the number of registrations limit is exceeded, delete the unwanted contents. [Refer to (b)]

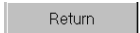
- Click on  to return to the **Connection Setting Screen**.

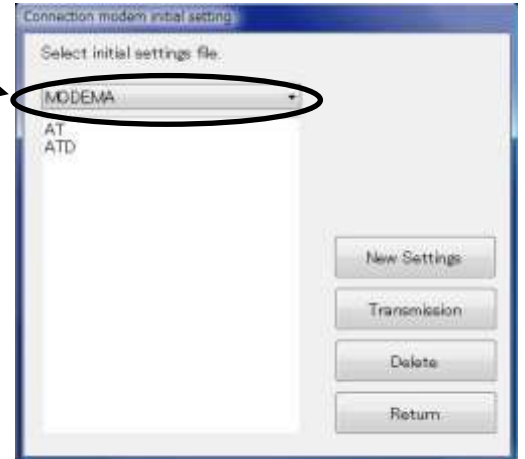

(b) Perform new modem setup.

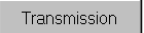
- Enter the command (you want to set) you want to send to the modem at the AT command input text. Then click on  to send the entered AT command to the modem. The response from the modem will appear below the entered AT command. Check the contents.

- After transmission to the modem is complete, click on . The contents sent to the modem will be registered as an initialize file. (Registered in the setup file list of the **Connection Modem Initial Setting Screen**.) At this time, do not forget to enter the registration name. Up to ten items can be registered. If ten items are already registered, new items cannot be registered. Delete unwanted items using the **Connection Modem Initial Setting Screen**.

- Click on  to return to the **Connection Modem Initial Setting Screen**.

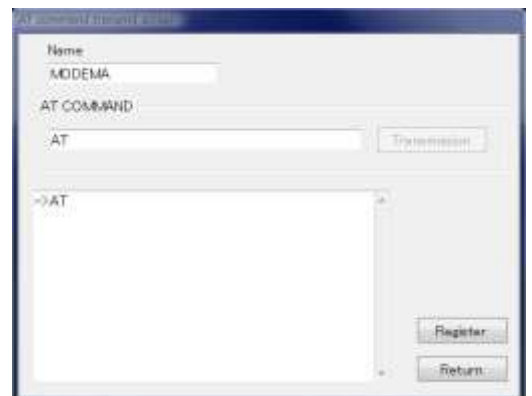

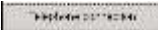

(4) Initiating the remote connection

To initiate the remote connection, click  on the remote setting screen.

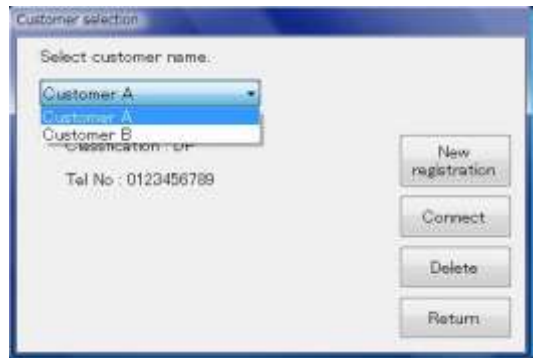
The **Customer Selection Screen** will appear. This screen connects to the on-site remote modem.



- (a) When the addressee has already been registered, select the customer name to be connected in "Select customer name box" and then click  to initiate connection.

In the case of initial connection or to change to a new addressee, click . Then the Customer Information Registration Screen will appear.

- (b) Enter Customer name of the field addressee, enter the type of the telephone circuit to be used and the telephone number of the addressee, and click . The set content will be registered.

* The contents transmitted to the modem vary in the chosen Line type.

Pay attention to the following.

When PB is chosen, "ATDT" is added before the telephone number.

For example, when a telephone number is 0123456789,

"ATDT0123456789" is transmitted to the modem. It becomes the following when "DP", "NONE" are chosen in the same way.

DP --- ATDP0123456789

NONE --- ATD0123456789

When a circuit connection is impossible in the case of above three which as well, "ELSE" is used.

When "ELSE" is chosen, nothing is added to before the telephone number.

Input a command for the circuit connection from the beginning.

For example, "ATD0,0123456789" is transmitted to the modem when "ATD0,0123456789" is inputted in the telephone number column.

When the one except for the "ELSE" is chosen, only a number can be inputted in the telephone number column.



The information for up to 100 customers can be registered. When the information for 100 customers has been registered, new customer information cannot be registered. Delete the unwanted customer information using the customer selection screen.

- (c) Check the contents, then click on .

The **Connection Status Indication Screen** will appear. Connect the line. When you want to disconnect the line, click on .

The line will be disconnected.



1.4.3 Starting the On-Line Monitor(USB/Serial conversion cable connection)

1.4.3.1 In case for local connection

This will be used when online monitoring is adapted to air conditioning system by connecting the Maintenance tool and USB/Serial conversion cable locally.

After turning off the power supply(circuit breaker) of air conditioning system, connect the USB / Serial conversion cable to the air conditioning system.

Caution:

- There is a danger of electric shock, please connect/disconnect the USB / Serial conversion cable after turn off the power supply(circuit breaker) of air conditioning system.
- For safety, Please put the junction board(Heat shrink tube part) of the USB/Serial conversion cable inside the outdoor unit and close the cover of the outdoor unit before turn on the power supply.
- Do not put the USB / serial conversion cable in a humid place.Do not get it wet.
- Do not pull or twist the USB / serial conversion cable.

(1) Clicking “USB/Serial conversion cable” on the selection screen of Monitor mode selects “P-series” or “M-series” simultaneously.

Select the COM port No. of the connected USB.

Last click  .

* By pre-inserting the USB/Serial conversion cable in the USB port, the USB COM port number will be displayed.



(2) Case of P-series select

Make sure to turn on the air conditioning system after the following notification is shown.

In case air conditioning system power has been kept on, please turn off the system then turn it on.



After click , monitor moves to the Connecting screen.

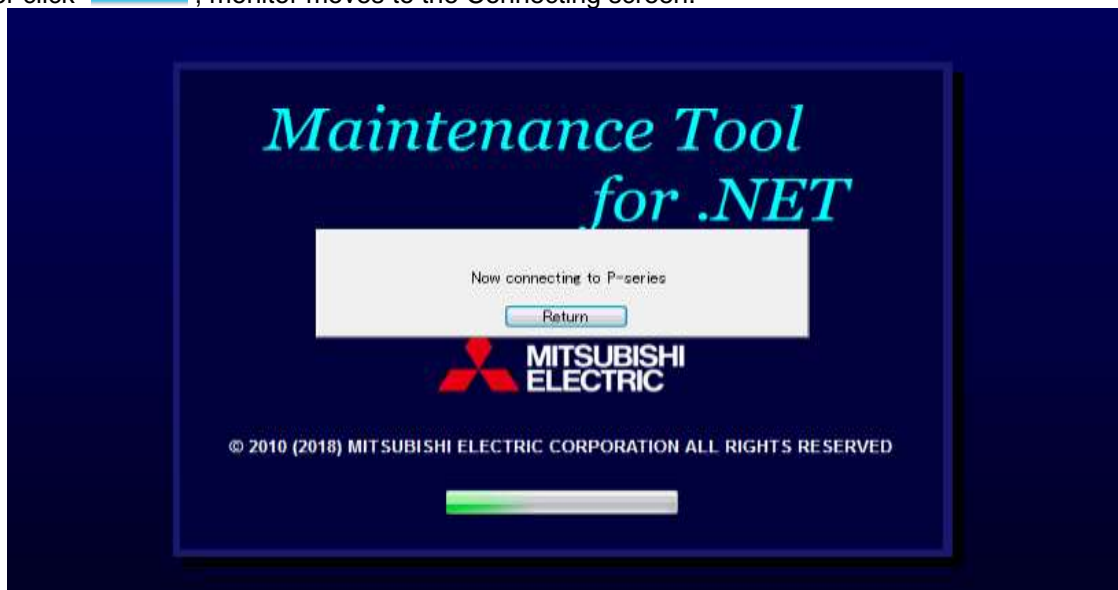

After collecting the information of air conditioning system, system automatically moves to Operation Monitor screen.

NOTE:

- In case you connect the maintenance tool with air conditioning system while air conditioning system power is on, communication error occurs and air conditioning system stops by error. In such case, please cycle power at the air conditioning system and reconnect maintenance tool.
- If you mistake Series selection ,you can return to the Select monitor mode screen by selecting "Return" button.

(3) Case of M-series select

Please turn on the power supply(circuit breaker) of air conditioning system after the following Title screen is displayed.

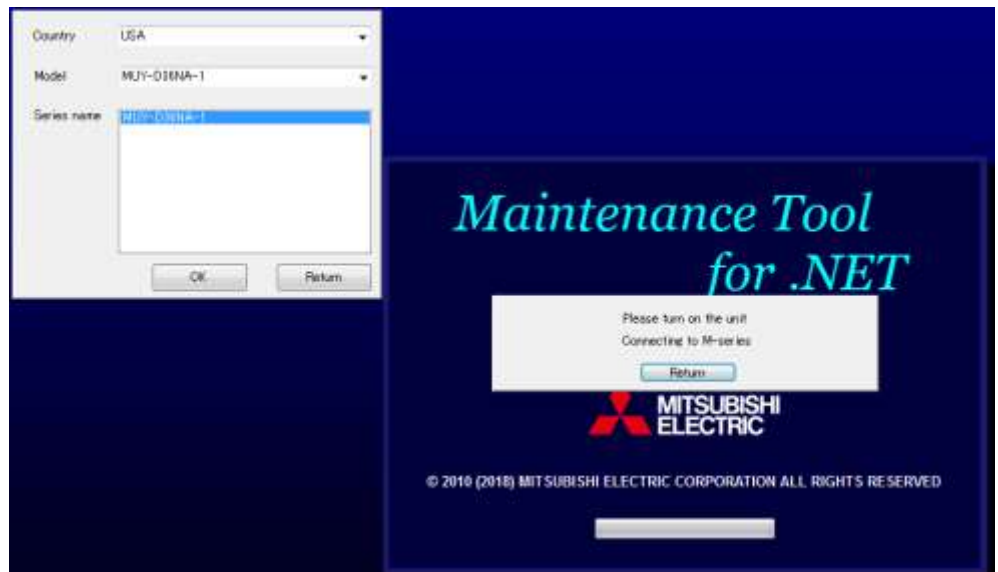

Select Country and the model / series name of the Outdoor unit to be connected and select "OK" button.

At this time, by entering the model name in the Model input field, it is possible to narrow down the model of the pull down list.

After acquiring the information of the unit, it automatically changes to the monitor screen.

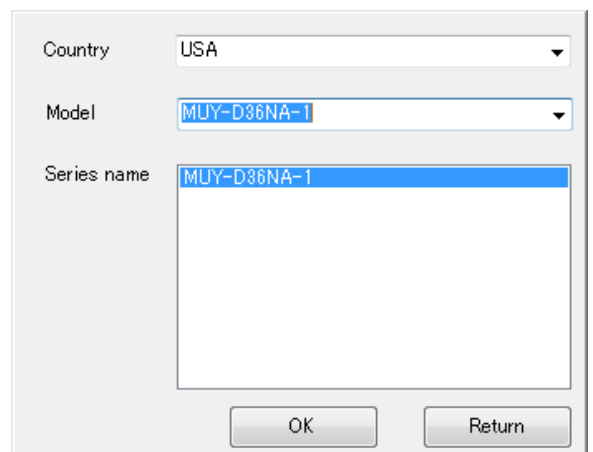

NOTE:

- If you mistake Series selection ,you can return to the Select monitor mode screen by selecting "Return" button.

1.4.4 Starting the On-Line Monitor(Centralized Controller connection)

To use the maintenance tool via Centralized Controller(Network), license registration for the Centralized Controller to be used is necessary.

Purchasing the license No. for each Centralized Controller be used, conduct the license registration through the Web browser ([http://\[IP address of the Centralized Controller\]/ administrator.html](http://[IP address of the Centralized Controller]/ administrator.html)). After selecting "Maintenance tool" of the optional function on the Web Browser Screen displayed, enter the purchased license No.

Refer to the following chapters in the "Web Browser Operation Manual" for detailed information about license registration.

Centralized Controller G-50A, AG-150A or GB-50ADA:Chapter4 [Registering a License for Optional Functions]

Centralized Controller EB-50GU, AE-200, AE-50 or EW-50:Chapter10 [License registration for optional functions]

When connecting maintenance tool via Expansion Controller,register the license in AG-150A connected by the Expansion Controller. (Only when AG-150A that registers the license is normally connected, it is possible to connect via Expansion Controller.)

* To use the maintenance tool via Centralized Controller (Only for LAN mode and Dialup connection mode), please check a setup of Internet Connection Firewall of PC. If the FIREWALL function is used, communication will be normally impossible with Centralized Controller, and normal data will not be displayed.

For detail, please refer to **[6. How to change setting of Firewall]**.

In the case of permanently installing an anti-virus software and always started under this environment, the fire wall function of this software may be activated sometimes. In such case, The normal communication with Centralized Controller will be hindered not displaying data normally. When operating Maintenance Tool, finish the anti-virus software once or remove the fire wall function.

1.4.4.1 In case for local connection

In the case when on line monitoring is applied to air conditioning system via Centralized Controller by connecting the Maintenance Tool to LAN locally.

NOTE:

- Though the warning shown on the right appears, this is not a problem. Simply click **[Unblock]** or **[Allow access]**.



- (1) Clicking “Centralized Controller (Network)” on the selection screen of Monitor mode selects “Local connection” simultaneously. Last click “”.



- (2) A message will appear prompting you to unblock **[MonitorManager]**.
 If **[MonitorManager]** is already unblocked, check the checkbox next To **[Do not show this message again]** to not show this message.
 Click **[Close]** to close the popup window.

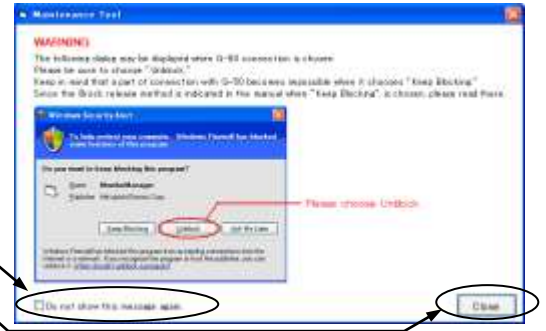

- (3) Next IP address input screen is displayed. Here, input IP address of Centralized Controller connected to the air conditioning system of which operating information is desired to monitor, and click on **[OK]**.

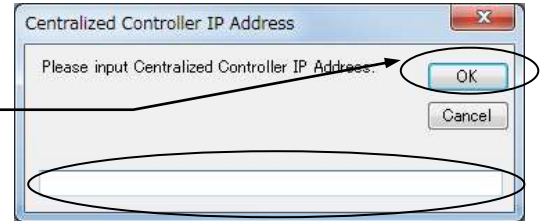

NOTE:

- It is required to set to the IP address in the same system with Centralized Controller to be connected to Maintenance Tool PC from [Control Panel].

1.4.4.2 In case for remote connection (Dialup)

In the case when on line monitoring is applied to local air conditioning system (with Centralized Controller installed) from the maintenance tool in the remote place via public telephone circuit.

* When utilizing Remote connection (Dialup), please prepare MODEM and DIAL-UP ROUTER (of a type allowing data communication by receiving external telephone transmission) for the connection with the public circuit in addition to the components used by Local connection (LAN).

For the system composition, please refer to the system diagram of (2)-1 in 1.1.2.

To use Remote connection (Dialup), it is previously required to register MODEM onto Windows and set the information on the receiver (the dial-up router at Centralized Controller in the field) of the telephone transmission onto the dial-up connection screen.

* If communication does not have for 10 minutes in remote connection, "Timeout occurred!" will be displayed, if O.K. is pushed, a telephone circuit will be cut automatically and the Maintenance tool will be ended.

- (1) After clicking "Centralized Controller(Network)" on the selection screen of Monitor mode, and click "REMOTECONNECTION(Dialup)." Last click " ".



- (2) Next **Remote Monitor screen** is displayed. Here select the connection name of the dial-up router at Centralized Controller in the field desired to be remotely connected. It is being set previously on the dial-up connection screen. Then input Dial-up user name and Dial-up password to connect with the dial-up router, and click on  .



After connecting to the telephone circuit, on-line monitoring can be performed as same as the case when connected with LAN.

1.4.5 Starting the Off-Line Monitor

When offline analysis is adapted to the data collected under ONLINE MODE.

- (1) Clicking “Offline Analyze” on the selection screen of Monitor mode.

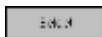
Last click “”.



1.4.6 Using the Wide area access mode

Under the “Wide area access mode,” the access method for remote connection can be registered to the database of each customer enabling easy online connection with the air conditioning system of the customer desired to be accessed.

[Remote access method]

- **LAN** : Accessing by directly connecting Maintenance Tool PC and Centralized Controller with LAN (WAN).
- **Dialup** : Accessing by dialup connection to Centralized Controller via public network.
- **Modem (MN Converter)** : Accessing by connecting Modem to MN Converter via public telephone circuit.

After the online connection performed by any of the above methods, you may use the similar function as that obtainable in the normal online connection.

While under the offline mode, customer information will be provided to the monitored data enabling only to select a specified customer for display.

NOTE:

Even when connecting under the wide area access mode, cautions will be applied as same as under the normal connection mode. You are kindly requested to observe the cautions described in the connection method under normal mode as well. (1.4.1 - 1.4.4)

1.4.6.1 Online Connection

- (1) Clicking “Online Connection (Wide area access mode)” on the section screen of Monitor mode.
Last click “  ”.



- (2) The customer registration screen will be displayed. Register customer information in the order of [1] -> [2] -> [3] hierarchically.

- [1] Area name
- ↳ [2] Customer name
- ↳ [3] Air conditioning system name & connection method

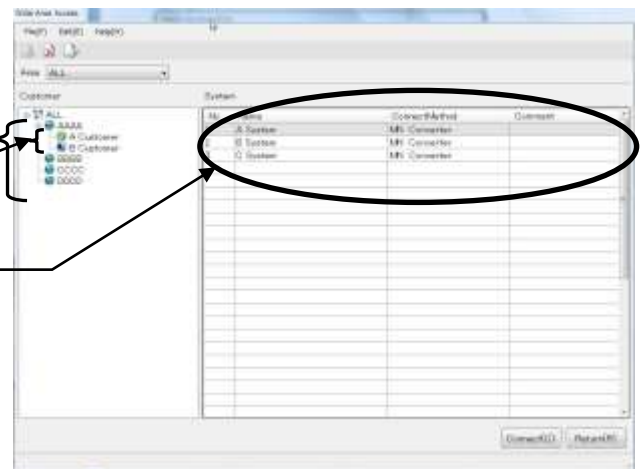

(a) Creating the [Area name] folder

- 1) When [Wide Area] is being onfigu, the sub-menu will be displayed by right-clicking.
- 2) Select [Add Area].
- 3) As the screen to enter the AREA name appears, set a proper Area name and press [OK] to create the Area folder.



(b) Creating the [Customer name] folder

- 1) Right-clicking the [Area name folder] to be registered displays the sub-menu.
- 2) Select [Add Customer].
- 3) As the screen to enter the Customer name appears, set a proper customer name.



* In addition to the above mouse operation, the creation of [AREA name] and [Customer name] can be set from the **menu bar (File)** or **tool bar (Figure)**.

By applying the same operation procedure(right-clicking, menu bar, tool bar), each folder can be deleted. Also the name of each folder can be changed.

Caution:

If a folder is deleted, all information (customer name, air conditioning system name, etc.) will be deleted similarly.

(c) Setting the [Air conditioning system name]

- 1) Under the state when the [Customer name folder] desired to be set on the air conditioning system is onfigu, the sub-menu will be displayed by right-clicking the air conditioning system list at the right screen.
- 2) Selecting [Create ...] displays [Setting screen of air conditioning system].

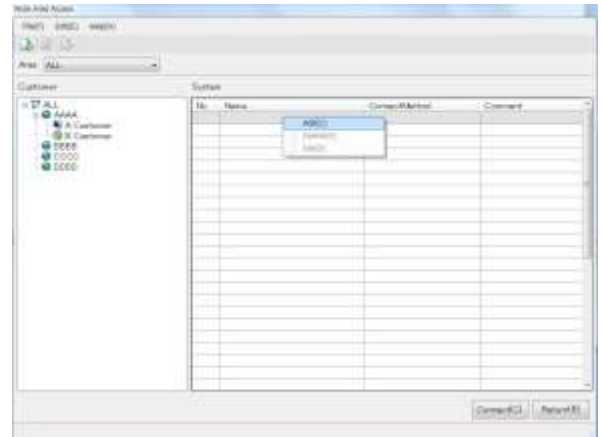
**[Setting screen of air conditioning system]**

- 1) Set the system name.
- 2) Select the method to connect with the system.
 - To connect by using **LAN (WAN)**, enter the IP address of Centralized Controller to be connected. (Same as 1.4.4.1)
 - To connect by using **Dial-up**, select the [Connection name] of dialup router of the local Centralized Controller being previously set on the dialup connection screen of Windows. And enter [User name] and [Password] for the connection with the dialup router, and lastly enter the IP address of Centralized Controller. (Same as 1.4.4.2)
 - To connect remotely with **MN Converter and Modem**, select [Modem(MN Converter)].
- 3) Enter special notes if any on the comment column. After entering and selecting the above, press [OK].

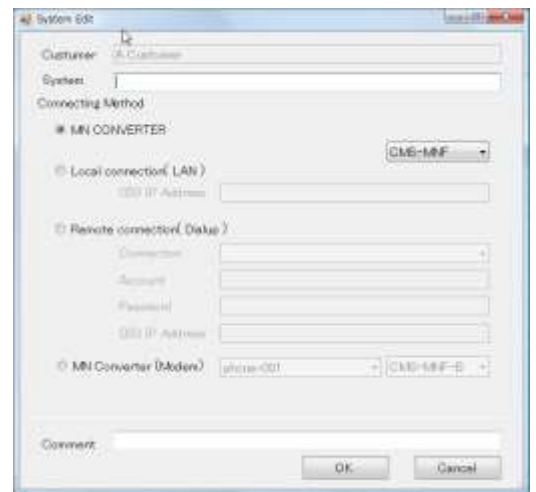

Set various information as required by repeating the items **(a)~(c) above**.

Using the area selecting section allows you to extract the only area desired to display.

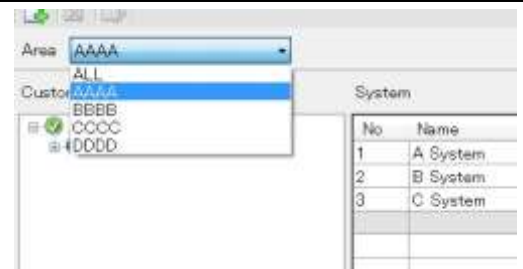

- (3) Focussing on the air conditioning system desired to be connected and pressing [Connect] will start the procedure for connection. After completing the normal connection, the screen moves to the online main screen allowing normal online operation. However when the connection method uses [Modem(MN Converter)], the screen of the Modem remote connection will appear. In this case, select the Modem to be connected and proceed the connection procedure.(Refer to 1.4.2.2.)

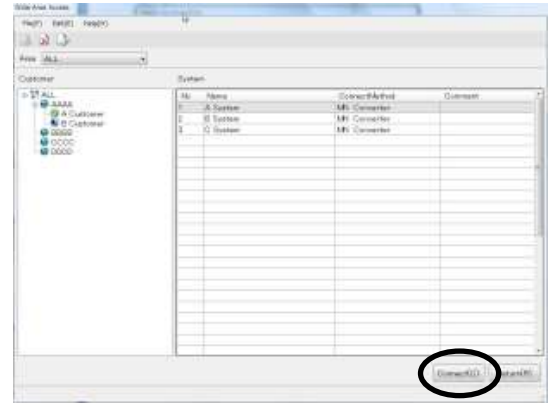

1.4.6.2 Offline Analyze

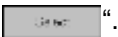
- (1) Clicking “Offline Analyze (Wide area access mode)” on the section screen of Monitor mode. Last click “  ”.



1.4.7 Ending the Maintenance Tool

1.4.7.1 Ending the On-Line Monitor

- (1) Open the **Main Screen**.
- (2) Click on **[File]** on the menu bar.
- (3) Click on **[Return]** in the sub-menu.
- (4) The message **“Are you sure you want to finish maintenance tool?”** will appear.
Click on .

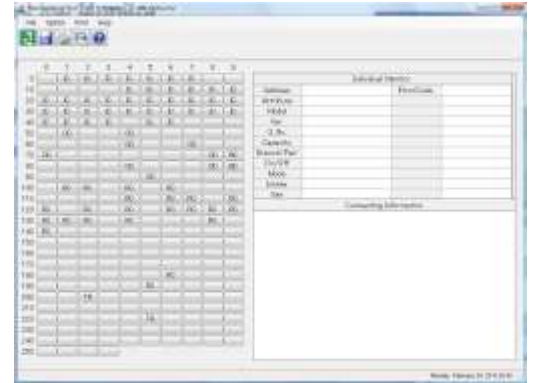

The On-Line Monitor will end and the Windows screen will appear.

*At ending of Maintenance Tool, the telephone circuit will automatically be disconnected.



* Clicking returns to the [selection screen of Monitor mode].

NOTE:

In case of connection using USB / Serial conversion cable, Main screen is not displayed and, the Select Monitor mode screen is displayed instead. Please refer to 1.4.7.3.

1.4.7.2 Ending the Off-Line Monitor

- (1) Open the **Off-line Analyze Screen**.
- (2) Click on .
- (3) The message **“Are you sure you want to finish maintenance tool?”** will appear.
Click on .



* When finishing Offline Screen immediately after deleting data, a message of “Finishing Maintenance Tool !!” may sometime be displayed. The internal data is now under arrangement. Offline Screen will automatically be finished after completing this process. Please wait a while.



* Clicking returns to the [selection screen of Monitor mode].

1.4.7.3 Ending the Mode select Monitor

- (1) Open the **Select Monitor Mode** screen.
- (2) Click on  .



2.1 Design of Screen

The design of the screen is shown below.

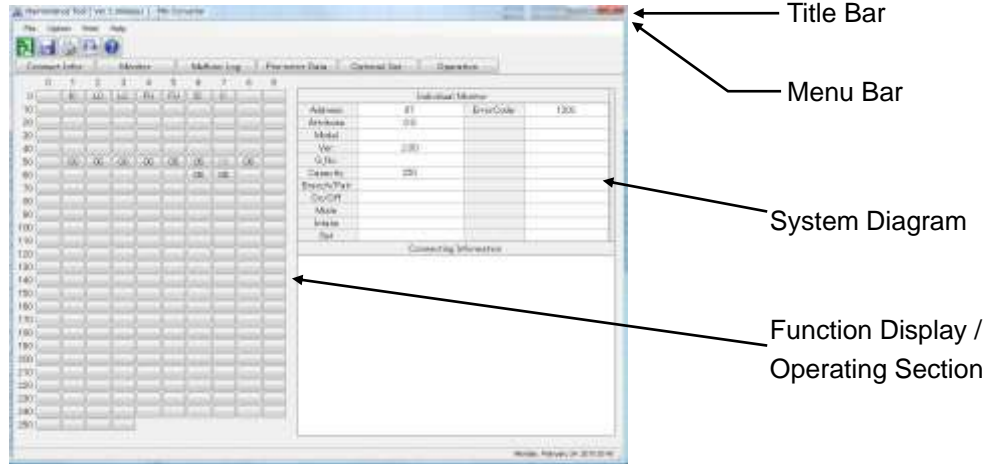

- Title Bar

Displays the title of the screen.

- Menu Bar

Displays the functions that can be performed using the current screen.

Click on an item and a sub-menu or message screen will appear, as shown in the illustration.

If a sub-menu appears, further function selections can be made.

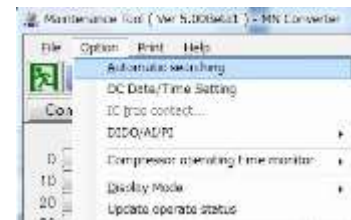

(Example of what the screen looks like when option is clicked.)

- Function Display / Operating Section

Displays the contents of the screen and the operation to be performed.

NOTE:

In case of connection using USB / Serial conversion cable, this screen is not displayed.

2.2 Operating Method

The following operations are performed by mouse.

(1) Click

Align the mouse pointer with the desired button and press the left button on the mouse. This is known as a click.

In general, all Maintenance Tool operations are performed with click operations.

(2) Drag

A drag is when the mouse pointer is moved while the left button is held down.

If you desired to check the bottom screen when two or more screens are being displayed on top of each other, align the mouse pointer with the title bar of the top screen and drag it. The bottom screen can now be seen.

3

On-Line Monitor Operating Method

3.1 On-Line Monitor Screen Transfer

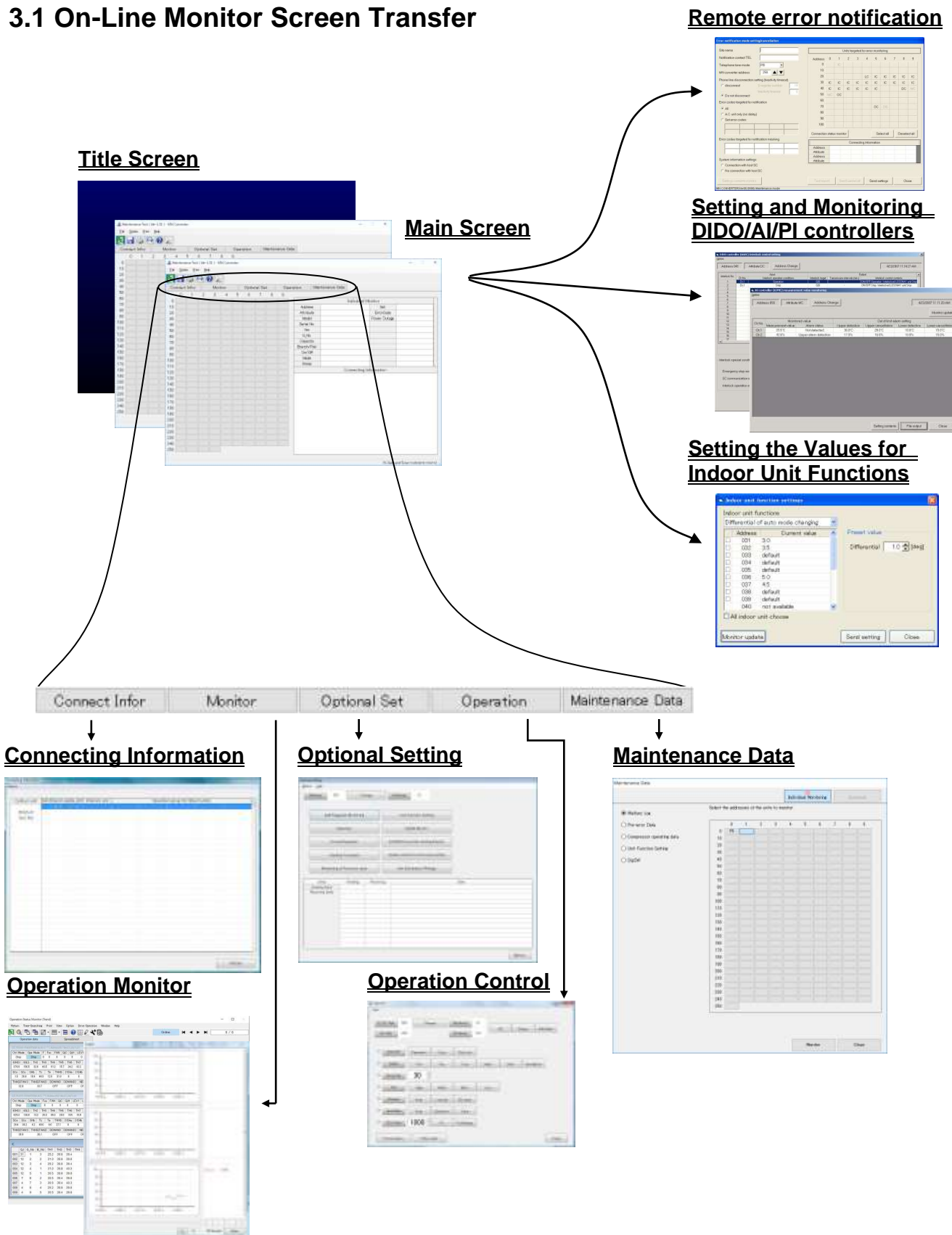

NOTE:

In case of connection using USB / Serial conversion cable, Operation monitor is displayed after Title screen.

3.2 Function Chart

Connecting Information ----- [Refer to 3.7]

This allows monitoring of the indoor units connected to the outdoor unit and of the interlock units and the operation group SC connected to indoor units.

Or this allows monitoring of a network information of the Expansion Controller (PAC-YG50ECA-J) and that upper controller's connection informations.

Operation Monitor ----- [Refer to 3.8]

This allows monitoring of the operating condition of the unit and operating data. The operation data obtained will be shown in the form of a graph.

This also allows the display of the refrigerant circuit diagram.

Utilizing the mail communication mode in addition, the operation monitoring data collected by Centralized Controller can periodically be transmitted to remote mail servers, and it can be referred as the off-line data later.

*The Mail communication mode can not be used with MN Converter connected.

Optional Setting ----- [Refer to 3.9]

This allows use of functions such as self-diagnosis monitoring.

Operation Control ----- [Refer to 3.10]

This allows the same operation as with the remote controller.

Maintenance Data ----- [Refer to 3.11]

Error history and pre-error data can be monitored and downloaded.

OC Date / Time Setting ----- [Refer to 3.12]

A setup of the present time can be performed to all outdoor units at the same time.

Free contact of indoor unit ----- [Refer to 3.13]

When utilizing the [Indoor unit free contact mode] which uses the external input/output of Free Plan indoor unit (Building-Multi) together with Centralized Controller and TG 2000A, the contact action of the indoor unit can be tested with this function.

Remote error notification ----- [Refer to 3.14]

When an error occurs in the air conditioning unit, the remote error notification function allows previously registered destinations to be automatically notified of the error via telephone lines. (This function can only be used with the MN Converter CMS-MNG-E.)

Setting and Monitoring DIDO/AI/PI Controllers ----- [Refer to 3.15]

Settings and monitoring DIDO Controller (PAC-YG66DCA), AI Controller (PAC-YG63MCA), and PI Controller (PAC-YG60MCA) can be made. (PI Controllers can be used only for monitoring.)

DIDO Controllers and AI Controllers have an interlock control function.

DIDO Controllers can also change the operation status of M-NET devices (such as indoor units, DIDO Controllers) by sending operation commands. DIDO Controllers can output contacts on DIDO Controllers themselves depending on the change in input contact status.

AI Controllers can change the operation status of M-NET devices (such as indoor units, DIDO Controllers) by sending operation commands depending on the change in measurement values.

"Interlock operation conditions" for the "interlock control function" can be set on Maintenance Tool.

Setting the Values for Indoor Unit Functions ----- [Refer to 3.16]

The preset settings for each function of the connected indoor units can be displayed, set, or changed.

Compressor operating data monitor ----- [Refer to 3.17]

Cumulative compressor operation time and the total number of startup times of the outdoor units and chillers can be monitored. When replacing the circuit board, cumulative compressor operation time and the total number of startup times can be written to the new circuit board.

Initial Settings and Monitoring AHC ADAPTER ----- [Refer to 3.18]

Initial settings and monitoring AHC ADAPTER

Fixed value setting of compressor frequency ----- [Refer to 3.19]

This allows lock the compressor to a fixed frequency.

Indoor unit LEV problem detection support ----- [Refer to 3.20]

This function automatically identifies the indoor units with possible locking of the LEV.

Detection of the incorrect port connections/settings ----- [Refer to 3.21]

This function helps detect incorrect port connections/settings for the simultaneous heating/cooling CityMulti system (R2).

-Connecting to P/M-series

In case of connection using USB / Serial conversion cable, the applicable items are following.

- Operation Monitor[Refer to 3.8]
- Operation Control [Refer to 3.10].

3.3 Address Search Method

3.3.1 Address Search Method Selection

- (1) Start the M-NET Maintenance Tool and the **Select The Address Searching Method Screen** will appear after the **Title Screen**.
- (2)
- (3) Select the address searching method, and click **[Standard]**, **[Detail]**, or **[Simple]**.
- (4) Click on either or to select the address search method.

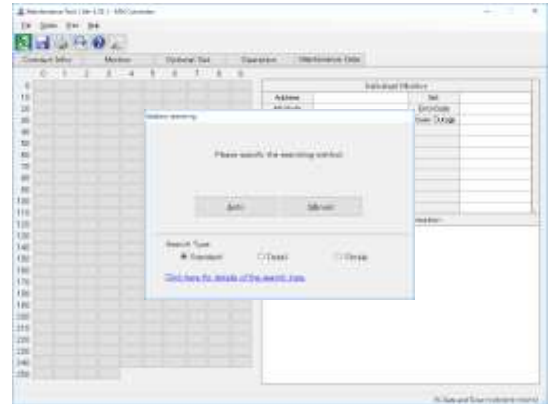

* **Automatic Search**

The Maintenance Tool automatically searches for and displays information about units connected to the M-Net transmission line.

* **Manual Search**

The user optionally searches for the units connect to the M-Net transmission line.

3.3.2 Address Search Type

The search type can be selected according to the purpose.

The following table shows the information to be searched and the required search time for each search type.

	Simple	Standard	Detail
Address	<input type="radio"/>	<input type="radio"/>	<input type="radio"/>
Attribute	<input type="radio"/>	<input type="radio"/>	<input type="radio"/>
Model		<input type="radio"/>	<input type="radio"/>
Serial No.		<input type="radio"/>	<input type="radio"/>
Ver.		<input type="radio"/>	<input type="radio"/>
G_No.	<input type="radio"/>	<input type="radio"/>	<input type="radio"/>
Capacity	<input type="radio"/>	<input type="radio"/>	<input type="radio"/>
Branch/Pair	<input type="radio"/>	<input type="radio"/>	<input type="radio"/>
On/Off			<input type="radio"/>
Mode			<input type="radio"/>
Intake			<input type="radio"/>
Set			<input type="radio"/>
ErrorCode			<input type="radio"/>
Power Outage			<input type="radio"/>
Connecting Information	<input type="radio"/>	<input type="radio"/>	<input type="radio"/>
Display color of attribute	<input type="radio"/>	<input type="radio"/>	<input type="radio"/>
Search time	2 seconds/address	5 seconds/address	7 seconds/address

NOTE:

The information to be searched and the required search time may vary with the model.

3.3.3 Automatic Searching

- (1) Click on and the **Automatic Address Searching Screen** will appear.
 - The time required to complete the automatic search will depend on the PC.
 - The address currently being searched for is displayed as **[Address]**. Up to 250 addresses can be searched for.
 - Click on to end automatic search. The **Main Screen** will appear.

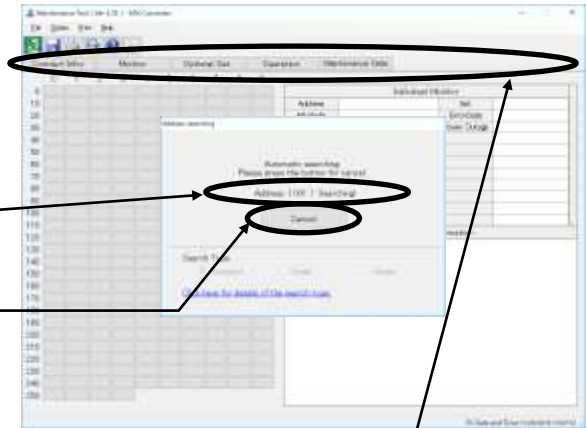

- (2) When automatic search has ended, the **Main Screen** will appear. Returning to the **Main Screen** enables the **[Function Buttons]**.

3.3.4 Manual Searching

- (1) Click on and the **Main Screen** will appear.
- (2) Click on the **[Button]** of the address desired and searching will begin.

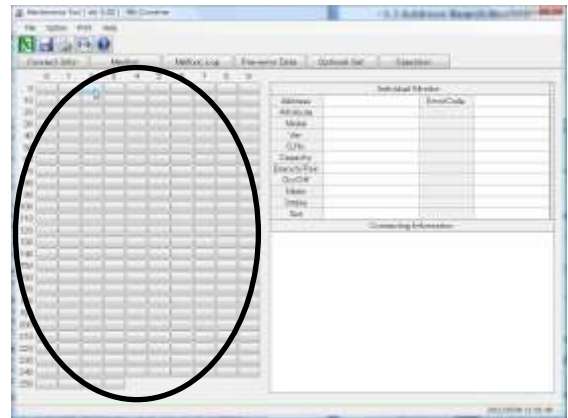

NOTE:

When a system is changed, please search an address after re-starting a Maintenance tool and Centralized Controller.

3.4 Main Screen

The operations in **3.3 Address Search Method** have made information about the units known. The **[Unit Attributes]** are displayed on top of the address buttons. The **Function Buttons** are now enabled at this time.

- (1) When the cursor is set to the address where the attribute is displayed, the unit information and refrigeration chart will be displayed in the [Unit Information Display Columns].

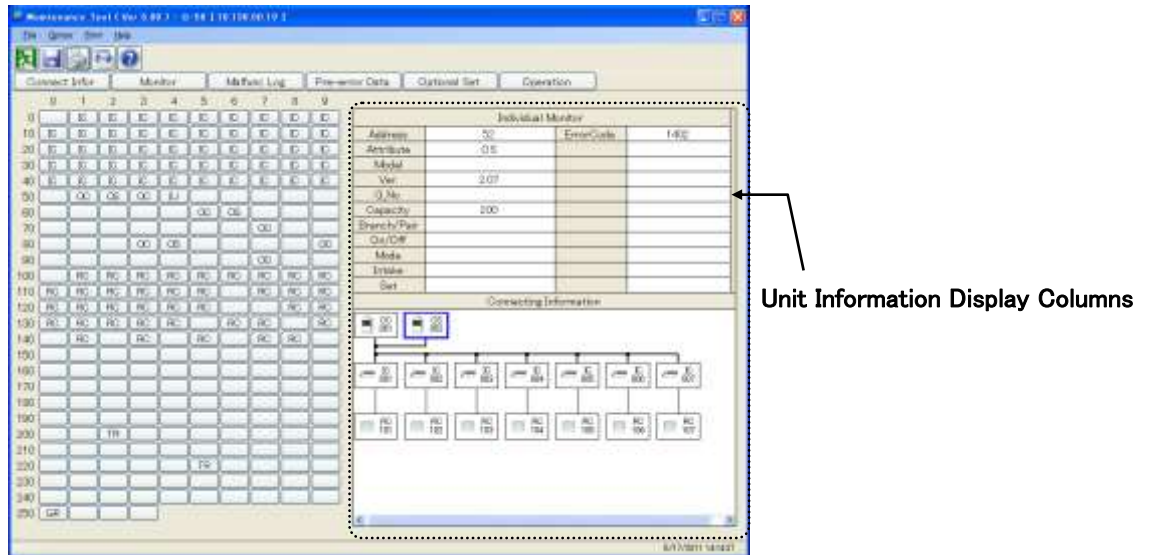

- * There are the following restrictions in the refrigeration chart.
 - Corresponding units are OC(OS) , BC(BS) , IC , LC(Lossnay) , FU(Fresh Master) & RC(Remote Controller). Other units are not displayed.
 - The refrigeration chart is reproduced based on the connection information of each unit. It is different from the actual piping connections & transmission lines.
 - The heavy line in the refrigeration chart shows connections between outdoor units , indoor units & Bccontrollers.
 - The thin line in the refrigeration chart shows the connections between indoor units , remote controllers & system controllers.
 - The double line in the refrigeration chart shows interlocking connections between indoor units , fresh master units & Lossnay units.
 - Only the refrigeration chart for the selected outdoor unit is displayed.
 - Unless the addresses for all units have been retrieved , the refrigeration chart will not be displayed fully.

NOTE:

- The colors in which some attributes (OC, OS, IC, LC, and FU) are displayed change according to the changes in the operation status. They will be displayed in black when the units are stopped; red, when they are in error; magenta, when they are stopped due to power failure; and green, in all other status (i.e., in operation).
- The background of the units that are stopped due to power failure will be displayed in magenta only when the search is conducted in the **[Detail]** mode. When the search is conducted in other address search modes, the background will appear in black.
- Some models (freezers, Mr. Slim etc.) do not support this function, in which case the attributes will be displayed in gray.

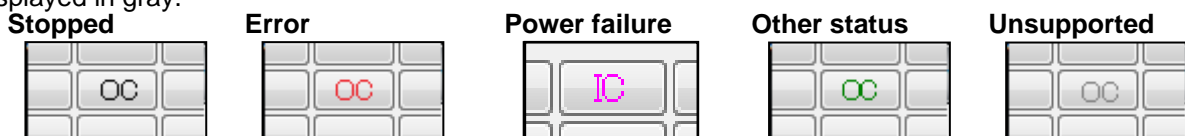

- When unit information has been changed from the factory setting, the Model name and Serial No. are displayed in blue. For details on unit information writing, refer to "3.9.7 Unit Information Writings."

Model	XXXX-XXX-XXX
Serial No.	XXXXXXXXXX

If the error code is displayed in blue, you can view the troubleshooting (PDF document) by clicking the error code

Individual Monitor			
Address	51	ErrorCode	1302
Attribute	0C		
Model	PURY-P250TLMU/YLMU		
Ver.	2.00		
G_No.			
Capacity	250		
Branch/Pair			
On/Off			
Mode			
Intake			
Set			

Click

Error Code [1302] (during operation)

1. Error code definition

High pressure fault 1 (Outdoor unit)

2. Error definition and error detection method

- 1) If the pressure of 3.78MPa [548psi] or higher is detected by the pressure sensor during operation (the first detection), the outdoor stops once, turns to antirestart mode for 3 minutes, and restarts after 3 minutes automatically.
- 2) If the pressure of 3.78MPa [548psi] or higher is detected by the pressure sensor again (the second detection) within 30 minutes after the first stop of the outdoor unit, the outdoor unit stops once, turns to anti-restart mode for 3 minutes, and restarts after 3 minutes automatically.
- 3) If the pressure of 3.87MPa [561psi] or higher is detected by the pressure sensor (the third detection) within 30 minutes of the second stop of the outdoor unit, the outdoor unit will make an error stop, and the error code "1302" will be displayed.
- 4) If the pressure of 3.78MPa [548psi] or higher is detected more than 30 minutes after the stop of the outdoor unit, the detection is regarded as the first detection, and the operation described in step 1 above will start.
- 5) For 30 minutes after the stop of the outdoor unit, preliminary errors will be displayed on the LED display.
- 6) The outdoor unit makes an error stop immediately when not only the pressure sensor but also the pressure switch detects $4.15^{+0.15}_{-0.22}$ MPa [601^{+0.22} psi]
- 7) Open phase due to unstable power supply voltage may cause the pressure switch to malfunction or cause the units to come to an abnormal stop.



3. Cause, check method and remedy

Note

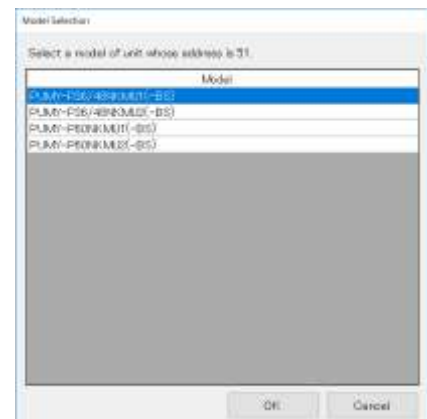
- Only some City Multi models support the troubleshooting function.
Non-City Multi models such as refrigerators and chillers do not support the function.
- To use the troubleshooting function, Adobe Acrobat Reader must be installed on your PC.
The troubleshooting function will not work properly on a PC without Adobe Acrobat Reader installed.
- To display the troubleshooting for PUMY-series units, click the error code, and select the model name in the model selection screen.
If the model name is not selected, the troubleshooting will not be displayed.





(2)The menu bar will display **[File]**, **[Option]** ,**[Print]** and **[Help]**.

- Click on **[File]** and "Save System Information" and "Return" sub-menu can be selected. Click on "Save System Information" and the message "Are you sure you want to save the System Information?" will appear. Clicking  displays the screen to save data. Change the data name as required and save it. You may enter your comment also. Click on  to return to the Main Screen. [Refer to 5.1 System Information Data.]





Click on "Return" to end the operation of the On-line monitor. [Refer to 1.4.6.1 Ending the On-Line Monitor]

- Click on **[Option]** and "Automatic searching" and the "Stop mail communication" sub-menus can be selected. * At the connection of MN Converter, "Stop mail communication" is not displayed. Click on "Automatic searching" and the message "Start the automatic searching. Is it OK?" will appear. Click on  to perform automatic searching or click on  to return to the Main Screen.

For more information about automatic searching, refer to [3.3 Address Search Method 3.3.2 Automatic Searching].

Click on "Stop mail communication", and the Stop mail communication Screen will appear.

Clicking on  stops the mail transfer processing of operation monitor data to remote mail servers.

After a while, the setting completion message appears. Clicking on  returns to the main screen.

Clicking on  returns to the main screen directly.



- Clicking on **[Print]** prints out the display currently shown on the screen.
- Click on **[Help]** and "Explanation of Terminology" and "Operation Method" sub-menus can be selected. [Refer to 3.6.1 Connecting Information of outdoor units 3.6.1.2 (2) "Menu Bar"]

NOTE:

"Stop mail communication" is a function to stop the operation monitor mail transmission of Centralized Controller under [mail communication mode] set in Chapter 3.7. It has no relation with (2)-2 E-mail connection mode of 1.1.2 On-line Monitor (via Centralized Controller).

NOTE:

[Stop mail communication] will not be available for selection by non-administrative users.

3.5 Function Selection Operations

- (1) First, click on the desired **[Function Selection Button]**.
- (2) Next, click on the **Unit to Operate**.
- (3) The screen will move to the various operation screens.
- (4) If the wrong function selection button is clicked, click on that button once again and the other function selection buttons will be enabled.

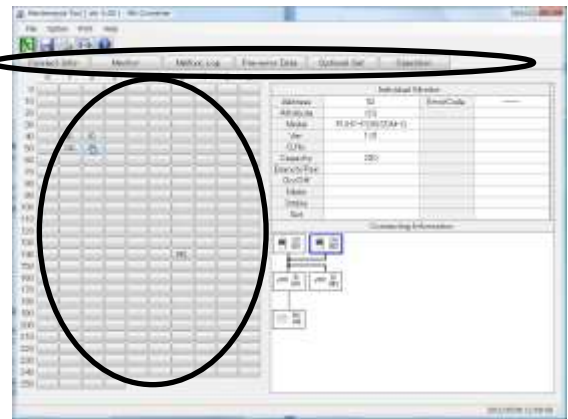

3.6 Display Mode Change

- (1) Click on  "List mode" then "Classic mode" then "Diagram mode" and then "List mode" and changes the screen.
- (2) The menu display mode, "List mode", "classic mode", "Diagram mode", and each can be switched.

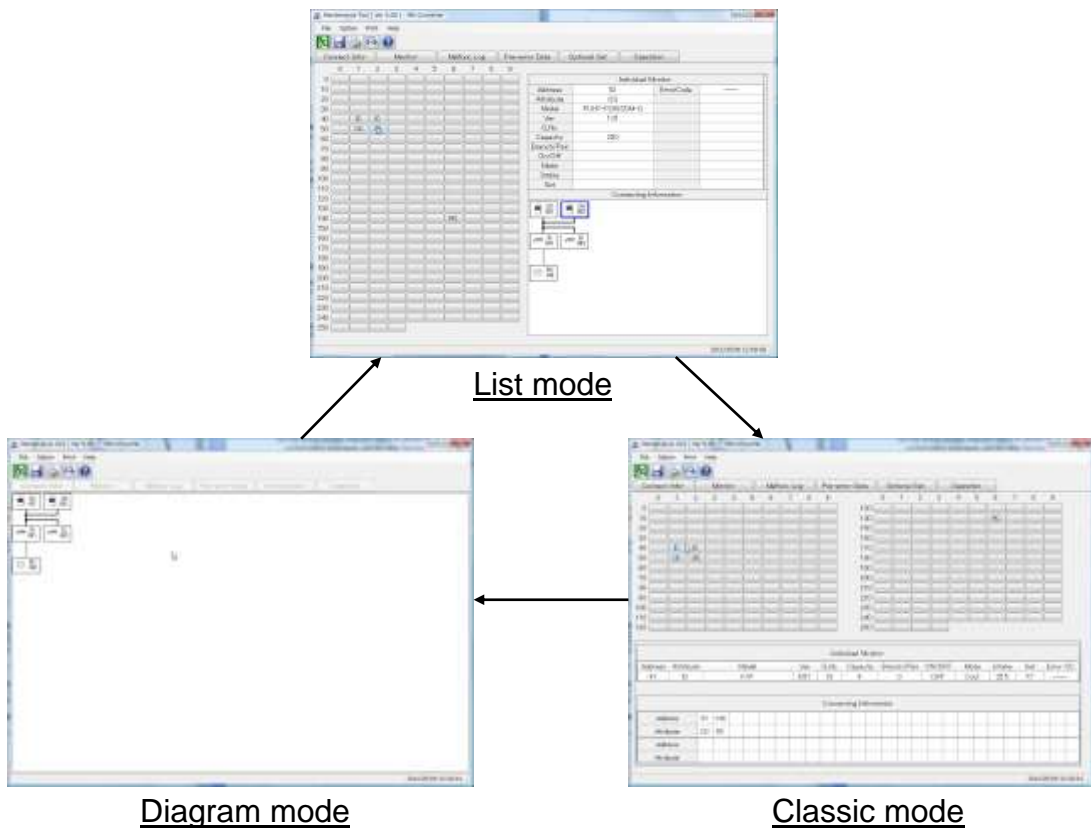

3.7 Connecting Information

Connect Infor

*** Items Performed Here**

- Indoor units connected to outdoor units, interlock units and the operation group SC (such as system controller and remote controller) connected to indoor units can be monitored here.
(Refer to **3.7.1 Connecting Information of the outdoor unit**)
- Network information of the Expansion Controller (PAC-YG50ECA-J) and that Centralized Controller's connection informations can be monitored here.
(Refer to **3.7.2 Connecting Information of the Centralized Controller and Expansion Controller**)

3.7.1 Connecting Information of the outdoor unit



- Indoor units connected to outdoor units, interlock units and the operation group SC (such as system controller and remote controller) connected to indoor units can be monitored here.
- Select and double-click the interlock units and operation group SC (remote controller only), the **Connecting Information Screen** will display as a pop-up menu.
The screen displays addresses and attributes of the units connected to the select unit.

3.7.1.1 Screen Transfer Operation

- (1) Click on **Connect Infor** on the **Main Screen**.
- (2) Click on the **OC** for the outdoor unit to be monitored.
- Only outdoor units and the Expansion Controller (PAC-YG50ECA-J) can be selected.
- (3) Momentarily, the message **"Monitoring! Please wait for a moment."** Will appear.

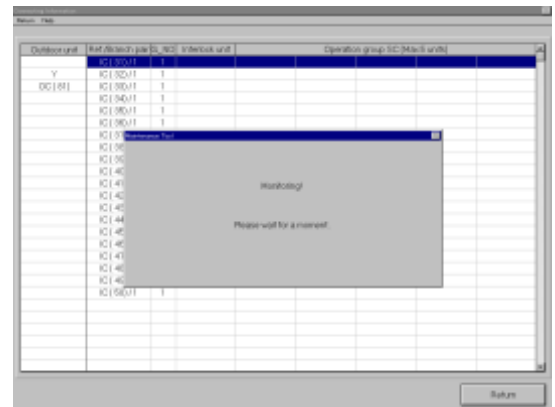

NOTE:

Even with the direct expansion type, when units other than the outdoor unit and other than the Expansion Controller(PAC-YG50ECA-J) are selected by (2), the screen returns to the **Main Screen** (where it waits for function selection input).

- (4) Momentarily, the **Connecting Information Screen** will appear.
- (5) Click on **Return** to end the **Connecting Information Screen**.
- (6) The message **"Finish the Connecting Information"** will appear.
Click on **OK** to end or click on **Cancel** to continue.
Click on **OK** and the Main Screen appears.

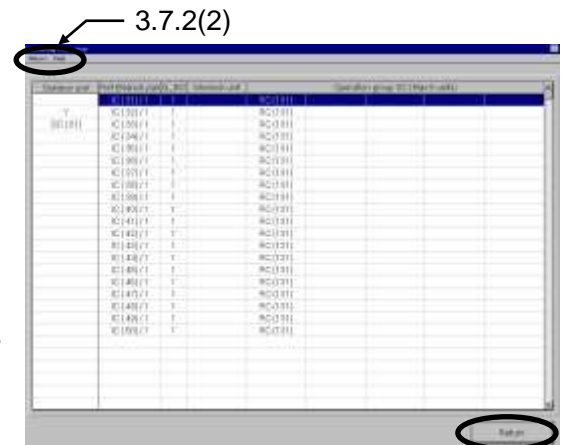

(5)

3.7.1.2 Screen Functions and Operation

- (1) Double-click on the interlock unit and operation group SC (such as system controller and remote controller), the **Operation System SC Connecting Information Screen** (in case operation group SC) will appear as a pop-up menu.

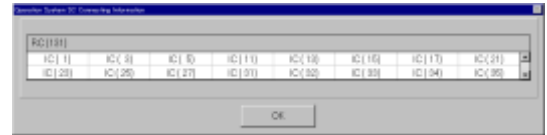

The screen displays addresses and attributes of each connected unit.

NOTE:

The **BC controller(BC)**, **Subsidiary outdoor unit(OS)** are indicated in the outdoor unit column.

- (2) **“Menu Bar”**

[Return] and **[Help]** appear in the menu bar.

Click on **[Return]** to end the **Connecting Information Screen** and return to the **Main Screen**.

Click on **[Help]** and the **Help Screen** appear.

- Click on **“Contents”** and the index for the **Help Screen** appear.
- Click on **“Back”** and the unit returns to its previous operating state.
- Click on **“Print”** and the currently displayed screen is printed. (Caution: Do not print while on-line. There is a chance that it could interfere with operation.)
- Click on **“Term”** and **Explanation of Terminology Screen** appear. Abbreviations, codes and other terms are explained on the explanation of terminology screen.

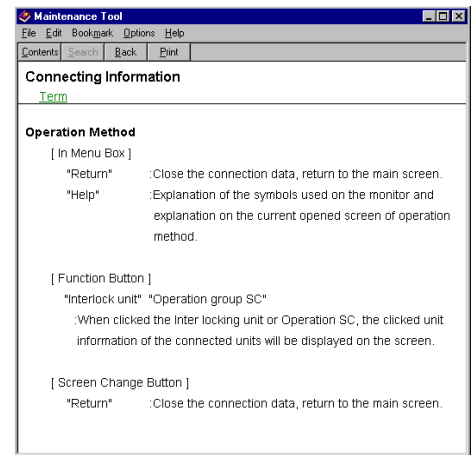

3.7.2 Connecting Information of the Centralized Controller and Expansion Controller

·Network information of the Expansion Controller (PAC-YG50ECA-J) and that Centralized Controller 's connection informations can be monitored here.

3.7.2.1 Screen Transfer Operation

(1) Click on **Connect Infor** on the **Main Screen**.

(2) Click on the  for the Expansion Controller or the Centralized Controller to be monitored.

NOTE:
Even with the direct expansion type, when units other than the outdoor unit and other than the Expansion Controller(PAC-YG50ECA-J) are selected by (2), the screen returns to the **Main Screen** (where it waits for function selection input).

(3) Momentarily, the **ECL Connecting Information Screen** will appear.
The monitor result to the Expansion Controller is displayed.
Refer to [3.7.2.2 Content of the Display Item] for the content of the display item.

(4) Click on **Close** to end the **ECL Connecting Information Screen**.

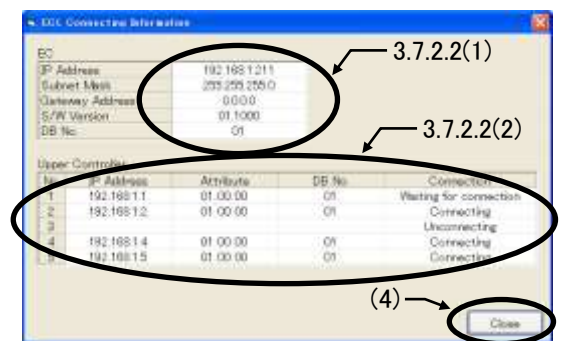

3.7.2.2 Content of the Display Item

(1) Content of the **“EC” Item**

Selected Expansion Controller's Network informations is displayed.

- IP Address : The Expansion Controller's Internet protocol address.
- Subnet Mask : Subnet mask value to the Expansion Controller's Internet Protocol address.
- Gateway Address : Gateway address on network where Expansion Controller is connected.
- S/W Version : The Expansion controller's software version number.
- DB No. : The Expansion controller's DB No..

(2) Content of the **“ Centralized Controller “ Item**

Connection informations of selected Expansion Controller's upper controller is displayed.

(The setting value of the Expansion Controller is displayed, excluding Connection Column.)

- IP Address : The upper controller's Internet protocol address.
- Attribute : The upper controller's attribute data.
- DB No. : The upper controller's database number.
- Connection : Connected state at upper controller and the Expansion Controller.
 - Connecting : The Expansion Controller and the upper controller is connecting now.
 - Waiting for connection : The Expansion Controller and the upper controller is not connecting now.
 - Unconnecting : The Expansion Controller doesn't have the upper controller's registration.

* When the Connection Column is a “Unconnecting”, that are displayed by the blank, excluding it.

3.8 Operation Monitor

Monitor

* Items Performed Here

- Monitors the operating condition and operating data of the current units every minute. This information can be displayed and saved.

- * When an excessively large number of the objective unit for monitoring exists, the monitoring interval may exceed 1 minute (70s, 80s, ---).
- * When the remaining storage capacity is getting insufficient during Operation Monitoring, Warning Screen will appear.
In this case, suspend the Operation Monitoring, move to Offline screen and delete unnecessary data to keep a proper capacity.

- * In case of connection using USB / Serial conversion cable, Operation monitor is displayed after Title screen. For this reason, Screen Transfer Operation[Refer to 3.8.1] and Operative diagnostic [Refer to 3.8.4] is not displayed.

NOTE:

The Operation Data Collection and Storage Functions of the outdoor units will be stopped while the operation data are being monitored.

3.8.1 Screen Transfer Operation

- (1) Click on on the **Main Screen**.

- (2) Click on the unit to be monitored.

If only outdoor unit is selected here, the operating data for the units connected to the outdoor unit will be automatically monitored.

The maximum number which can carry out a monitor changes with selected models.

An **error message** will appear if the limited number of units is exceeded.

- (3) After the units to be monitored have been selected, click on .

- (4) The message **"Monitoring! Please wait for a moment."** Will appear.

After a while, the screen to select monitor method appears.

When it is judged that monitoring with one minute cycle may not be performed because of many units to be monitored, a message of **[The monitoring cycle will be [* *] seconds due to too many IC units for monitoring. ---]** will be displayed automatically. To continue the monitoring, click [Yes], while to suspend it once to reduce the quantity of units for monitoring, click [NO]. Reduction of one IC can minimize the cycle time by about one second.

- * In "MN converter connection", it shifts to (7).

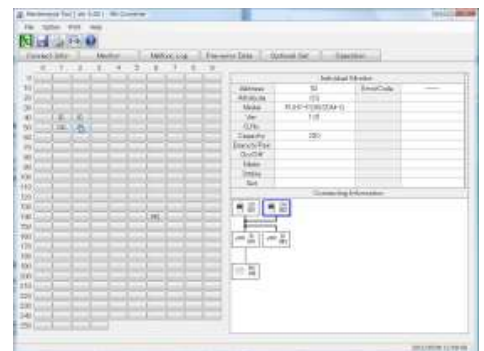

- (5) When desiring to observe the operation data immediately, select **[Realtime Monitor Mode]** and then click on . Select **[Mail communication Mode]** to observe the operation data by the off-line monitor later, after mail-transmitting the operation data beforehand by using the mail transmission function.



When **[Mail communication Mode]** is selected, the setting items of mail communication will be displayed.

- From: Mail Address

Set the mail address of the Centralized Controller in the [From: Mail Address] field. When sending mail via an ISP, set the mail address allocated by the ISP. When the mail server resides on the LAN, obtain the mail address from the LAN administrator.

* When sending mail via an ISP, a user contract with the ISP is required.



- To: Mail Address

Set the mail addresses of the recipients to which mail is sent.

* The mail address of recipient (To ) acquires and sets up the address only for Maintenance Tool.

- SMTP Server IP

Set the mail server IP address in the Mail Server Information [SMTP Server IP] field. When sending mail via an ISP, set the ISP address of the ISP mail server. When the mail server resides on the LAN, obtain the IP address from the LAN administrator.

* If the only information available on the ISP mail server is a domain name, use a PC to connect to the Internet, open a DOS prompt and type "ping *domain name*". Set the IP address that is displayed as the ping response.

- Monitor Finish Data

Set the date of monitor data transmit period.

- Mail Sending Interval

Set the transmit interval of monitor data (**max 240 min**).

Then click on .

After a while, it returns to the main screen, but the mail transmission to remote receivers will be performed by Centralized Controller automatically.

* At the connection of MN Converter "the screen to select monitor method" is not displayed. Real-time Monitor Mode is always commenced not allowing to use **[Mail communication Mode]**.

- (6) In the case of real time monitoring, the message "**Monitoring. Please wait for a moment.**" Will appear again.

(7) Momentarily, the **Operation Status Monitor Screen** will appear.

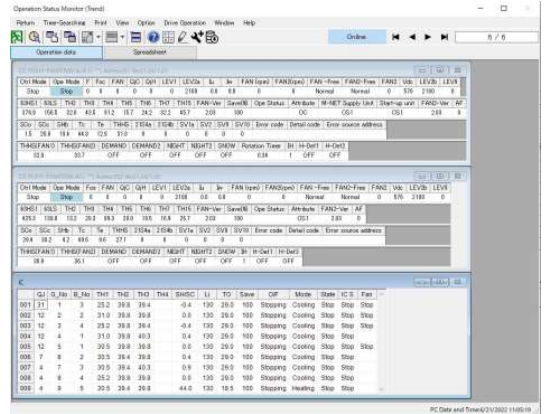

- (8) Click on to end the **Operating Status Monitor Screen**. The message **"Finish the operation status monitor"** will appear.
- Click on to end or click on to not end.
- Clicking displays the screen to save data.
- Change the data name as required and save it. You may enter your comment also.
- Clicking does not allow the data to be saved.
- Returning to the main screen.



3.8.2 Screen Functions and Operations

- The operating condition and operating data are displayed every minute.
- The **[Current Time]** is displayed. The **[Monitor ID]** is displayed when saving data.
[Refer to 5.2 Operation Status Monitor Data]

(1) "Operation Buttons"

[Operation] operation in the same manner as a remote controller.
[Refer to 3. 11 Operation Control]

Click on **[Return]** to end the operation status monitor and return to the **Main Screen**.
[Refer to 3.8.1(8)]

(2) "Menu Bar"

[Return], **[Time Search]**, **[Print]**, **[View]**, **[Option]**, **[Drive Operation]**, **[Window]** and **[Help]** are displayed on the menu bar.

- Click on **[Return]** to end the Operation Status Monitor and return to the **Main Screen**.

NOTE:

- When connecting to M/P-series with USB/Serial conversion cable, Click on **[Return]** button, then the screen return to the selection screen of monitor mode.
- When finishing monitor display which is shown right with P-series, make sure to turn off air conditioning system first then turn off the Maintenance tool. If do not follow above procedure, communication error occur and air conditioning system stops by error.

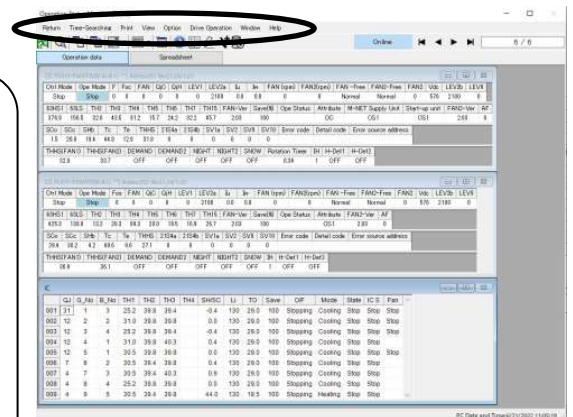

- Clicking **[Time Search]** open the "Time Searching"
- Click on **[Print]** and an explanation about "Print" and "Copy to Clipboard" will be displayed.
- Clicking **[Drive Operation]** open the "Operation Control Screen".

NOTE:

- In case of connecting to M-series with USB/Serial conversion cable, the Drive Operation is not displayed on the menu bar.

- Click on **[View]** and then select "Switch Trend Form" or "Switch Classic Form" from the sub-menu. Change the display format.

NOTE:

- In case of connection using USB/Serial conversion cable, the View is not displayed on the menu bar.





- Click on **[Help]** and an explanation about "Terminology" and "Operation Method" will be displayed.
[Refer to 3.7.1 Connecting Information of outdoor units 3.7.1.2 (2) "Menu Bar"]

(3) “Navigation Buttons”

Toggles the display of the retrieved data.

This feature is only form the trend.

This feature is supported in the “Operation Data” screen only.

- Clicking  In the data obtained shows the oldest data.
- Clicking  Display the previous data.
Direction keys on the keyboard can be used for switching.
- Clicking  Display the next data.
Direction keys on the keyboard can be used for switching.
- Clicking  Data obtained in the most recent data show.

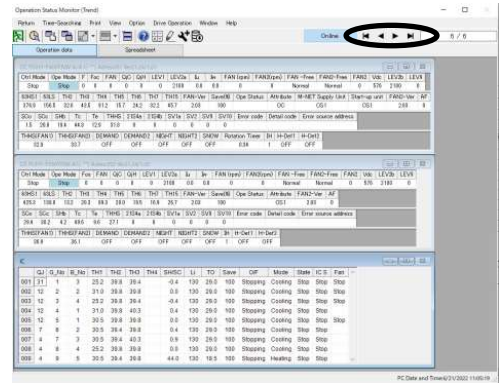

- Operating Status Monitor Screen(For MN Converter/Centralized Controller connection)

This screen displays the operation status and the operation data every minute.

The Operating Status Monitor Screen consists of multiple sub windows. As shown below, each sub window either displays the operation status of a single unit or of multiple units.

Sub windows can be maximized, minimized, or moved.

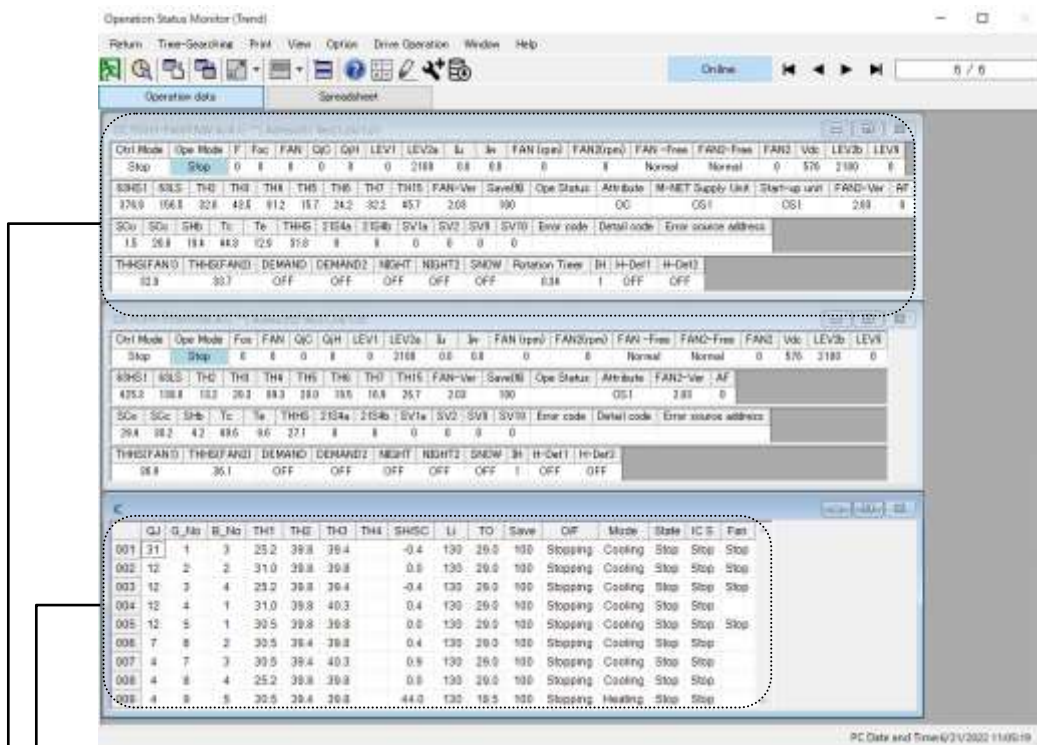

- The operation status of multiple units are displayed on a single sub window.
- Each row displays the status of a unit.
- A scroll bar will appear if a sub window contains more units than can be displayed all at once.

- The operation status of a single unit is displayed on a single sub window.
- The operation status of the unit is displayed in multiple rows.

Clicking the [View] button in the menu bar will switch between the two display formats: [Trend] screen and [Classic] screen.

[Trend] screen

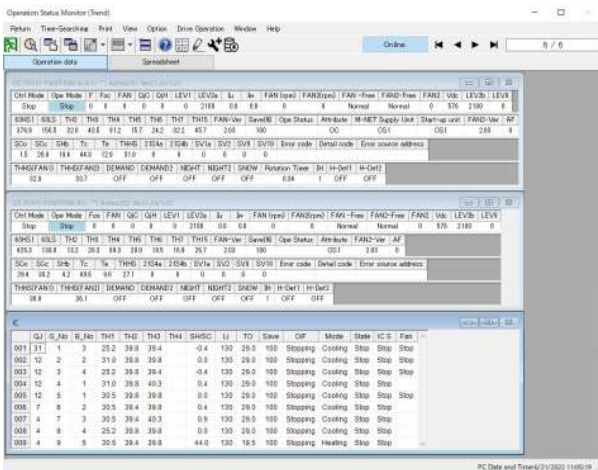

[Classic] screen

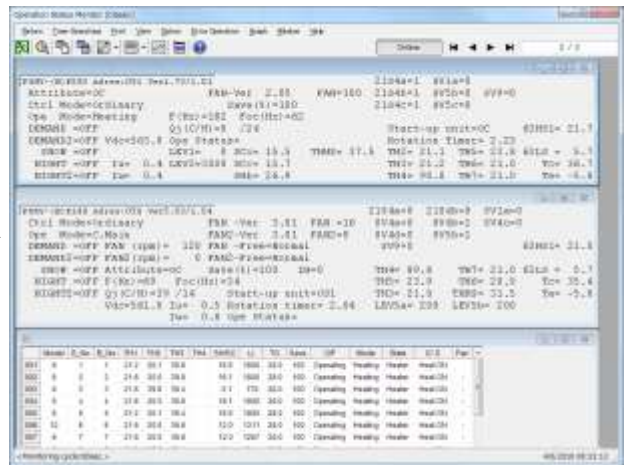

Note

- On the [Trend] screen, a selected cell can be highlighted in different color. Clicking a cell will change its color between green and white. The selection will be cleared when the operation monitoring is cancelled.



- Click the item to see the explanations of terms.

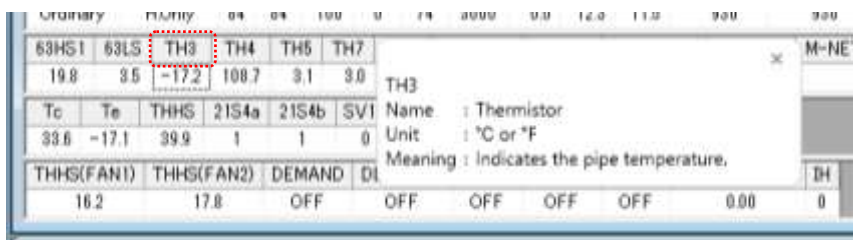

Note

- Some models do not support the display of data in the Trend display format. If the Trend display format is selected on the models that do not support this function, data will be displayed in the Classic display format.
- On some models, term explanations will not be displayed. See "8. Explanation of terminology" for explanations of terms.

- Operating Status Monitor Screen(For USB/Serial converter cable connection)

After displaying the title screen, the screen will change to the Operation Monitor screen.

The display screen when P / M-series is connected is as follows.

<P-series>

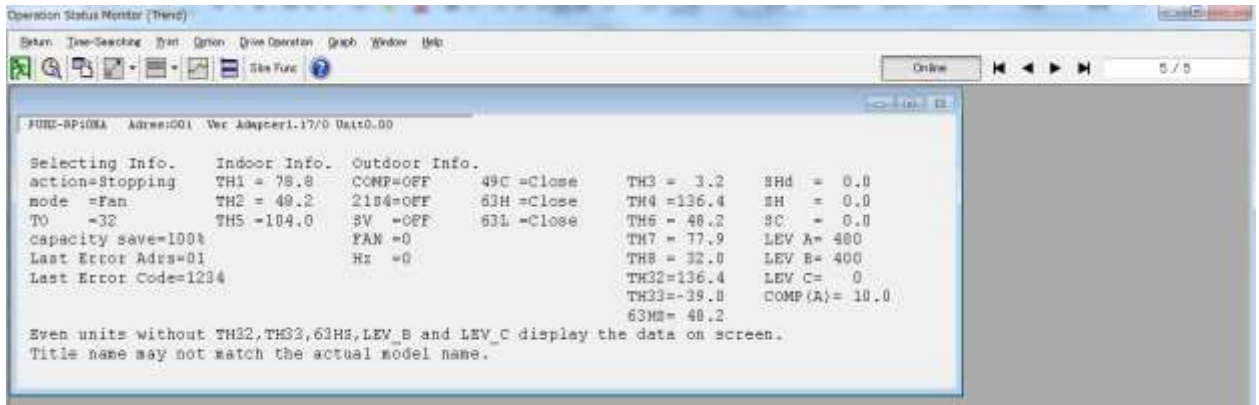

Note

- Refer to 3.8.2 “Screen Functions and Operations for the operation” about operation on the Operation monitor screen.
- Refer to 8“Explanation of Terminology” about the official name of the display items.

<M-series>

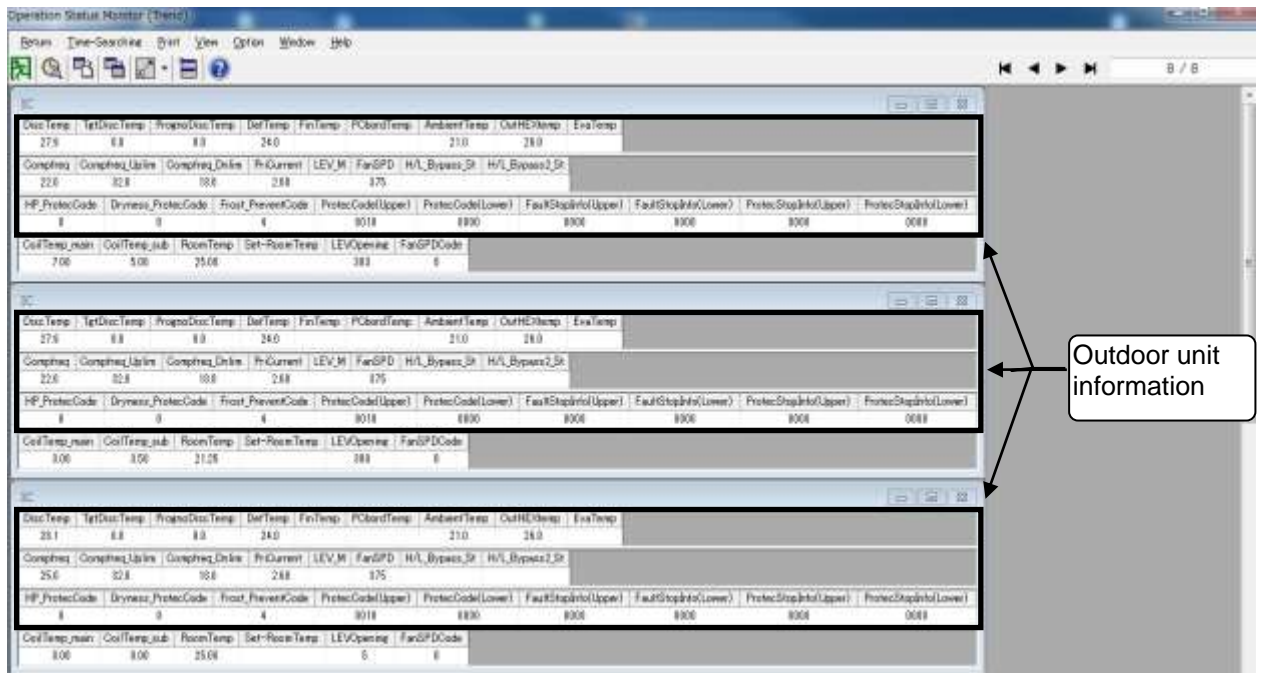

Outdoor unit information

Note

- In case of RAC,SUZ, the indoor unit and the outdoor unit information are displayed in one window.
- In case of MXZ,
 - Outdoor unit information is displayed duplicately in each indoor unit window.
 - The window is line up in order of A room ,B room,··· from the top.
 - Regardless of the number of connected indoor units, Windows is displayed the maximum number of outdoor units that can be connected
- Depending on the timing of monitoring, it may take invalid value when monitoring at the first time.
- Refer to 3.8.2 “Screen Functions and Operations for the operation” about operation on the Operation monitor screen.(It does not correspond to some functions such as operation)
- Refer to 8“Explanation of Terminology” about the official name of the display items.
 - Depending on the model, Monitorable data is different.
 - And unmonitorable data is shown as blank.

3.8.3 Spreadsheet

- Some models support the display of the spreadsheet.
- The display formats of the operation status and the operation data can be switched by using tabs.

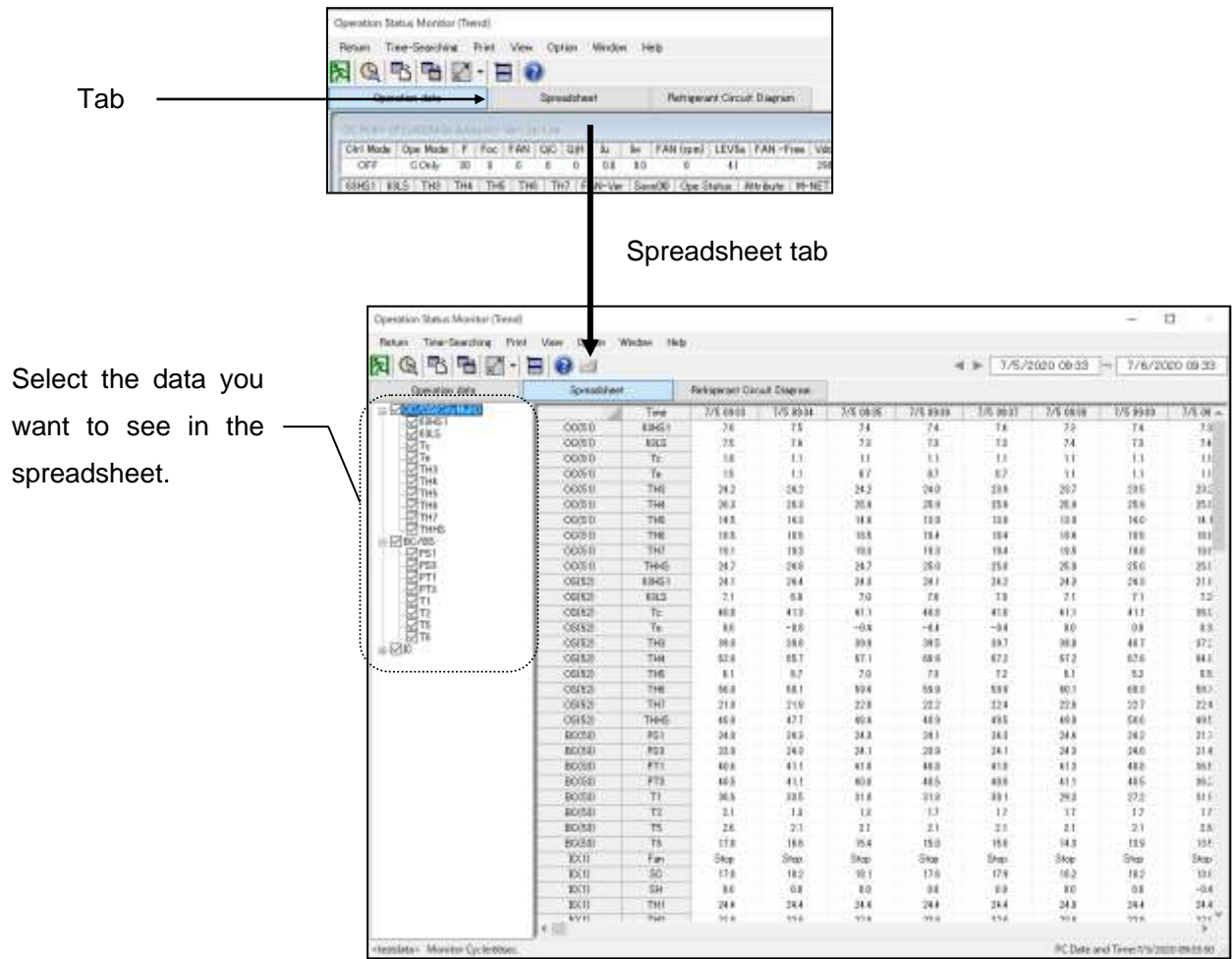

Note

- Clicking rows, columns, cells or  button at the upper left will change its color between green and white. The selection will be cleared when the operation monitoring is cancelled.

	Time	7/5 09:28	7/5 09:34	7/5 09:38
OC(5)	63LS	7.6	7.4	7.4
OC(5)	63LS	7.5	7.4	7.3
OC(5)	Tc	1.8	1.1	1.1
OC(5)	Te	1.8	1.1	1.1
OC(5)	TH3	24.2	24.2	24.2
OC(5)	TH4	26.3	26.3	26.9

- Click the item to see the explanations of terms.

63LS	7.5	7.4	7.3
Tc			
Te			
TH3			
TH4			
TH5			
TH6	18.5	18.5	18.5
TH7	10.1	10.2	10.2

63LS

Name : Low pressure sensor

Unit : kg/cm2 or Pound/inc2 or MPa

Meaning : Indicates the low pressure.

Click on [graph] button to display graph screen.

Operation Status Monitor (Trend)

Return Time-Searching Print View Option Window Help

Operation data Spreadsheet Refrigerant Circ

	Time	7/5 09:33
OC(5)	63HS1	7.6
OC(5)	63LS	7.5
OC(5)	Tc	1.8
OC(5)	Te	1.5

Click button

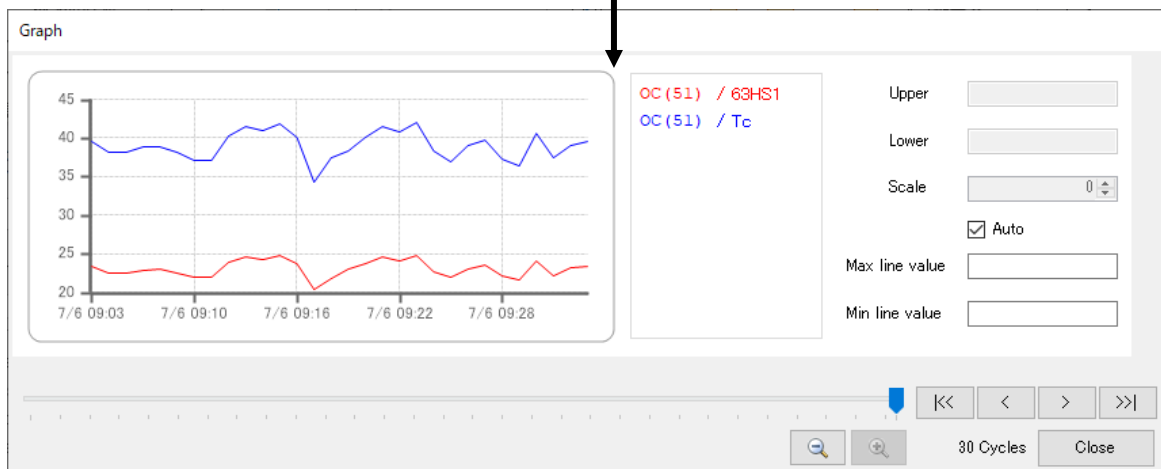

Note

- Some modes do not support spreadsheet function.
- The items that can be displayed on spreadsheet and graph screen differs depending on the model.

Click **[Add Operation data]** from the pulldown menu of **[Option]** on the menu bar, or click the corresponding icon to open the Add Operation Data screen. This function displays the user-customized items on the Operation Data screen. Customized calculation formula, such as the difference between the set room temperature and the return air temperature or the difference between the inlet and outlet water temperatures of the chiller, can be added that are calculated based on the existing items.

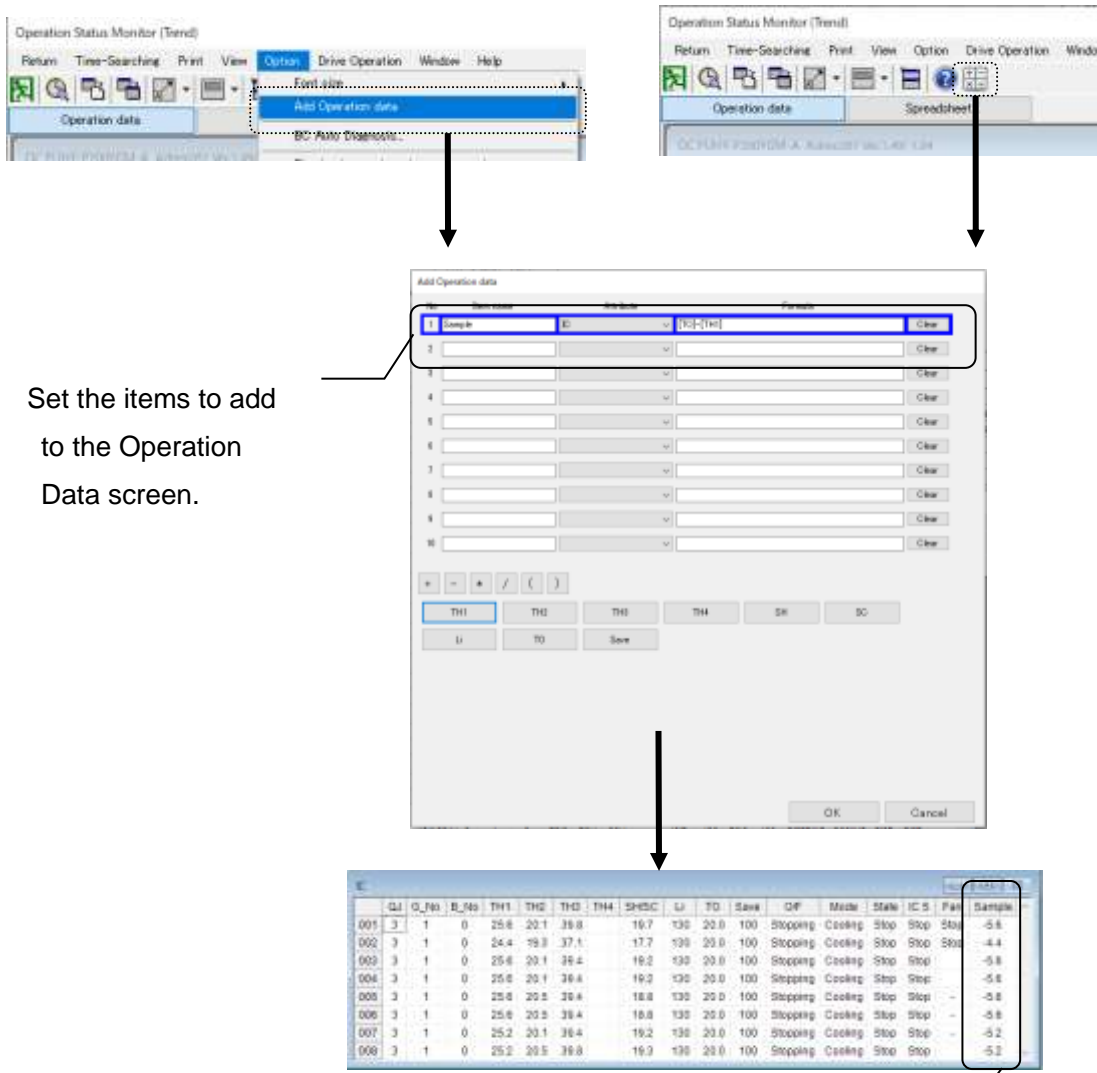

Set the items to add to the Operation Data screen.

Items set in the step above will appear here on the Operation Data screen

Add the items to be included in the operation data as follows.

- (1) Enter the item names. The items entered here will appear on the Operation Data screen.
- (2) Select the attributes from the pulldown menu.
- (3) Buttons corresponding to the item selected from the pulldown menu in step (2) above will appear. Click the desired button to add the item in the [Formula] field. Combine such items as [TO-TH1] or [TH4-TH1] and four arithmetic operations to create formulas.
- (4) Check the formula for validity.
- (5) Clicking the [Clear] button will clear all items entered. Use this button to correct errors in the formula.



- (6) Click the [OK] button to add the items to the [Operation Data] screen. Added items will appear at the bottom or at the right of the screen.

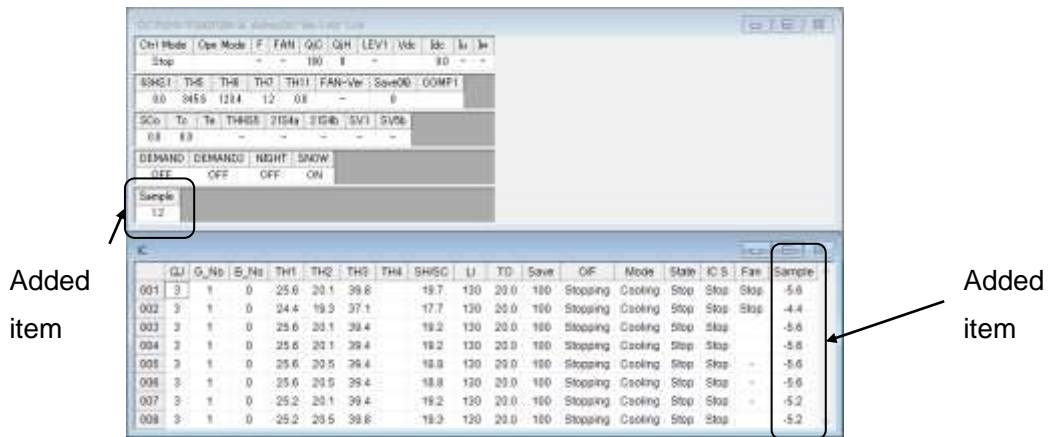

Note

- ① User-added items will not be included in the text format output(CSV file).
- ② The values that the customized formula refer to are only obtainable from the equipment with the same M-NET address.

Example: Sensor readings of the outdoor unit with M-NET address 51 and of the outdoor unit with M-NET address 52 cannot be used in the same formula.

Click **[Add Highlight Conditions]** from the pulldown menu of **[Option]** on the menu bar, or click the corresponding icon to open the **[Add Highlight Conditions]** screen. This function highlights the operation data that meet certain defined conditions.

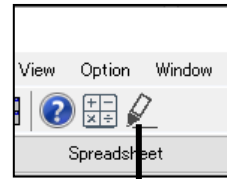

Define the highlight conditions.

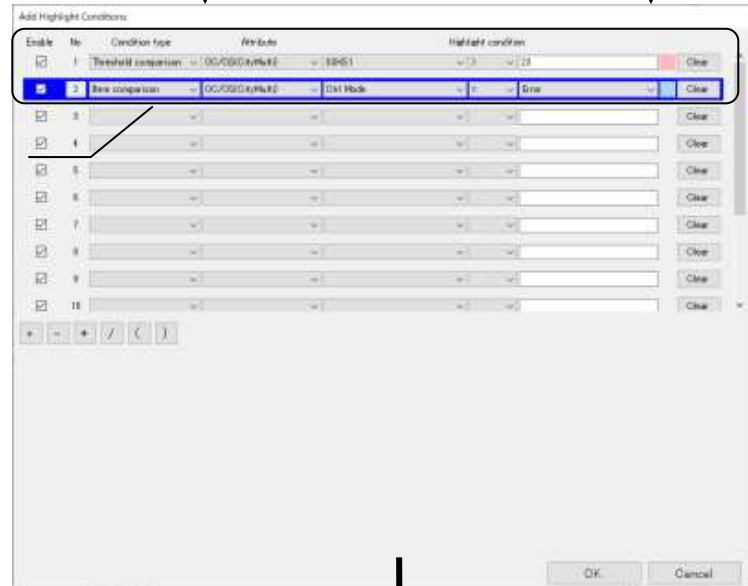

Ctrl Mode	Op Mode	F	Foc	FAN	G/C	Q/H	LEV1	LEV2	Vdc	Iu	Iw	Cln Timer(min)	FAN (rpm)	FAN-Free
68HS1	Cooling	33	33	100	92	0	75	757	264.0	18.0	17.9	0	820	
24.5		22	9.4	28.8	38.9	64.7	25.9	-94.8	36.3	3.05	180			
SCo	Stp	Tc	Tc	THS	2154a	SV1a	SV2	SV8						
5	18.9	41.5	8.0	68.5	0	0	0							
DEMAND	DEMAND2	NIGHT	NIGHT2	SNOW	Rotation	Timer	IH							
OFF	OFF	OFF	OFF	OFF	0.08	0								

Operation data that meet the defined conditions will be highlighted.

Add the highlight conditions as follows.

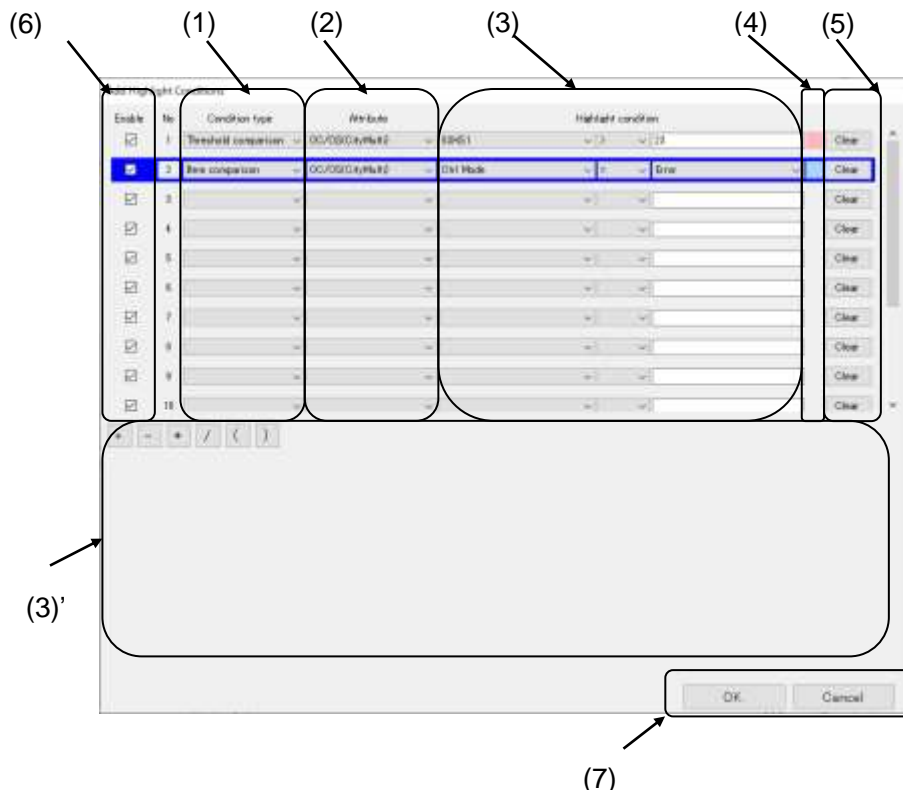

- (1) Select the highlight condition type. The method to define highlight conditions depends on the type selected.

Type	Method to define highlight conditions	Description	Example	
Threshold comparison	Item 1 ▼ Threshold	Symbol ▼	Item and threshold are compared. When the defined condition is met, the operation data are highlighted.	TH1 > 15
Item comparison	Item 1 ▼ Item 2 ▼	Symbol ▼	Item 1 and Item 2 are compared. When the defined condition is met, the operation data are highlighted.	Control mode = Error

- (2) Select the attributes from the pulldown menu.
- (3) Define the highlight conditions.
Highlight conditions can be defined for the equipment with the same M-NET address.
Sensor readings of the outdoor unit with M-NET address 51 and of the outdoor unit with M-NET address 52 cannot be used in the same highlight condition.

Item	Description																					
Item 1 ▼	Select the target item from the pulldown menu. When [Threshold comparison] is selected, items such as temperature sensor reading and pressure sensor reading (numerical data) are displayed in the pulldown menu. When [Item comparison] is selected, items such as operation mode and control mode (text data) are displayed in the pulldown menu.																					
Symbol ▼	Select the symbol from the pulldown menu. <table border="1"> <thead> <tr> <th>Symbol</th> <th>Example</th> <th>Description</th> </tr> </thead> <tbody> <tr> <td>></td> <td>A > B</td> <td>When value A is larger than value B, the operation data will be highlighted.</td> </tr> <tr> <td>>=</td> <td>A >= B</td> <td>When value A is larger than or equal to value B, the operation data will be highlighted.</td> </tr> <tr> <td><=</td> <td>A <= B</td> <td>When value A is less than or equal to value B, the operation data will be highlighted.</td> </tr> <tr> <td><</td> <td>A < B</td> <td>When value A is less than value B, the operation data will be highlighted.</td> </tr> <tr> <td>=</td> <td>A = B</td> <td>When value A is equal to value B, the operation data will be highlighted.</td> </tr> <tr> <td>NOT=</td> <td>A NOT= B</td> <td>When value A is not equal to value B, the operation data will be highlighted.</td> </tr> </tbody> </table>	Symbol	Example	Description	>	A > B	When value A is larger than value B, the operation data will be highlighted.	>=	A >= B	When value A is larger than or equal to value B, the operation data will be highlighted.	<=	A <= B	When value A is less than or equal to value B, the operation data will be highlighted.	<	A < B	When value A is less than value B, the operation data will be highlighted.	=	A = B	When value A is equal to value B, the operation data will be highlighted.	NOT=	A NOT= B	When value A is not equal to value B, the operation data will be highlighted.
Symbol	Example	Description																				
>	A > B	When value A is larger than value B, the operation data will be highlighted.																				
>=	A >= B	When value A is larger than or equal to value B, the operation data will be highlighted.																				
<=	A <= B	When value A is less than or equal to value B, the operation data will be highlighted.																				
<	A < B	When value A is less than value B, the operation data will be highlighted.																				
=	A = B	When value A is equal to value B, the operation data will be highlighted.																				
NOT=	A NOT= B	When value A is not equal to value B, the operation data will be highlighted.																				
Threshold	Buttons corresponding to the item selected from the pulldown menu in step (2) will appear in the field indicated as (3) in the figure above. Click the desired button to add the item in the [Threshold] field. Combine such items as [TO-TH1] or [TH4-TH1] and for arithmetic operations to create thresholds.																					
Item 2 ▼	Select the item to be compared with Item 1.																					

- (4) Select the highlight color. Clicking the button will change the highlight color. When the highlight condition is met, the operation data will be highlighted in the selected color.
Note that if multiple highlight conditions are met at the same time, the operation data will be highlighted in purple.

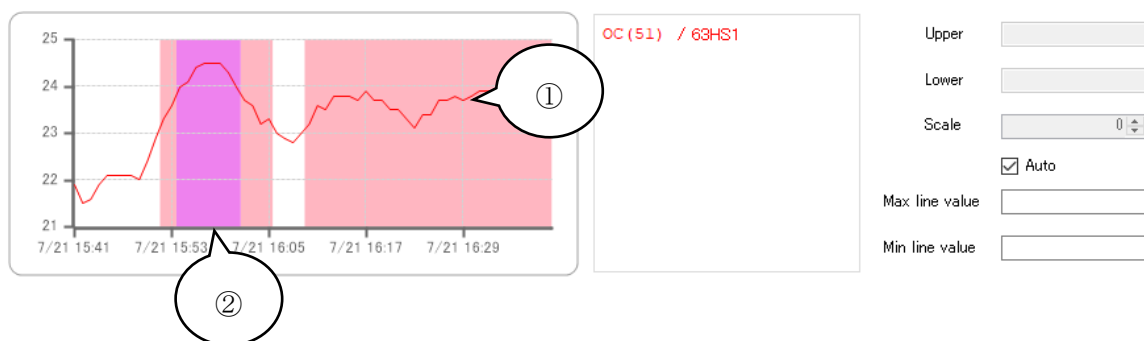

- ① Operation data will be highlighted in the selected color.
 - ② Operation data that meet multiple highlight conditions will be highlighted in purple.
- (5) Clicking the [**Clear**] button will clear all items entered. Use this button to change the highlight conditions.
- (6) Clicking the [**No.**] buttons will enable or disable the corresponding highlight conditions. Use these buttons to temporarily enable or disable the highlight conditions.

(7) Pressing the **[OK]** button will set the defined highlight conditions. Operation data that meet the highlight conditions will be highlighted.

The highlight conditions apply to the **[Trend]** screen, **[Spreadsheet]** screen, and **[Graph]** screen, not to the **[Refrigerant circuit diagram]** screen.

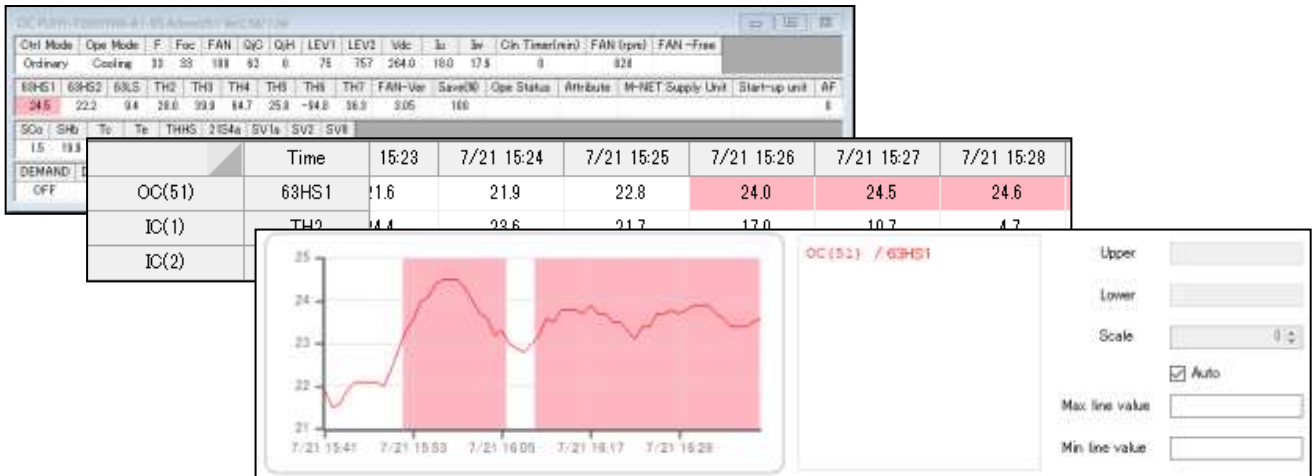

3.8.4 Refrigerant circuit diagram

- Some models support the display of the refrigerant circuit diagram.

The display formats of the operation status and the operation data can be switched by using tabs. The refrigerant circuit diagram tab displays the operation status and the operation data along with a refrigerant circuit diagram.

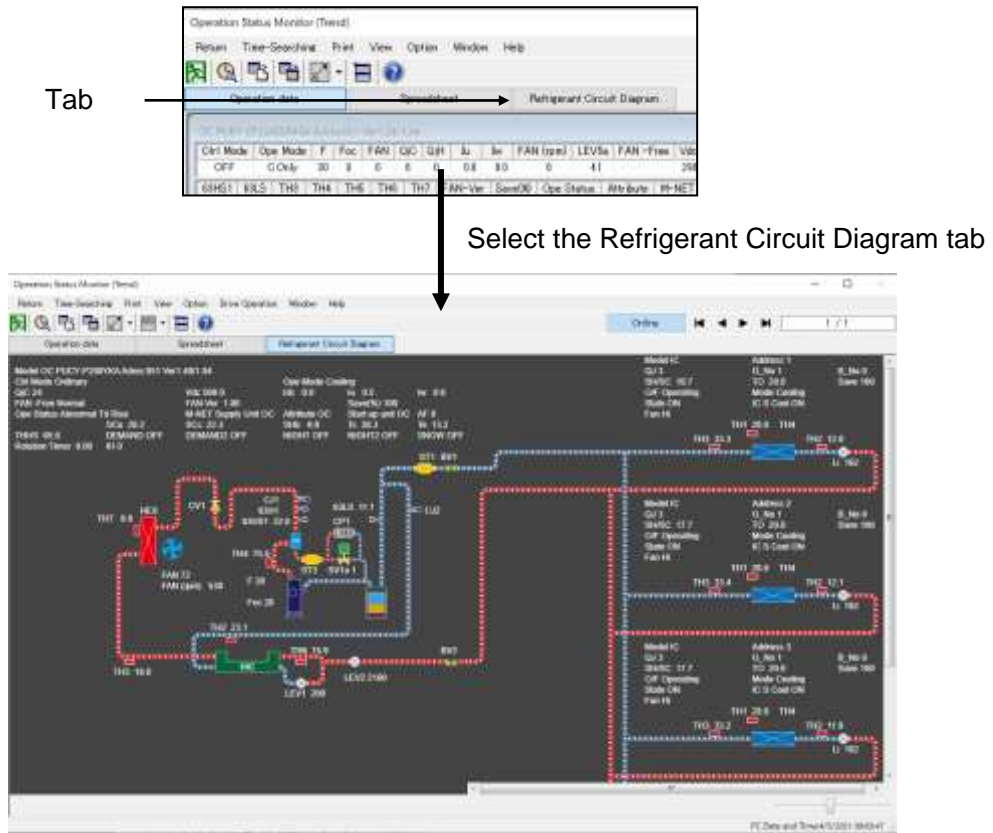

Note

- Only some City Multi and M-series models support the display of the refrigerant circuit diagram. Non-City Multi models such as refrigerators and chillers do not support the display of the diagram. If none of the units monitored support the display of the diagram, the tabs of the display formats will not appear, and the operation status and the operation data will be displayed in a chart.
- The refrigerant circuit diagram will be displayed when **[Display refrigerant circuit diagram]** in **[Option]** in the main screen is set to **[Active]**. When **[Display refrigerant circuit diagram]** is set to **[Inactive]**, the tabs of the display formats will not appear, and the operation status and the operation data will be displayed in a chart.

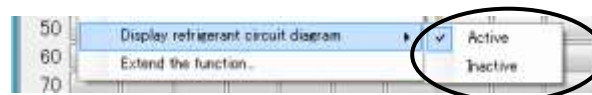

- The refrigerant circuit diagram is displayed only when the Operation Status Monitor Screen is accessed by selecting an OC.
- Only one refrigerant system can be displayed in the refrigerant circuit diagram. If two or more refrigerant systems are monitored, only a refrigerant system with the lowest OC address will be displayed.
- Only units that are monitored in the main screen are displayed in the refrigerant circuit diagram of ICs connected to OCs.
- The refrigerant circuit diagram indicates the refrigerant flow and actuator status in animation or color. These animations and colors only represent the normal unit operation and may differ from the actual unit operation.
- Some models of M-series do not support animation and colorization.

Caution

- To display the refrigerant circuit diagram of PUMY-series units, open the model selection screen from [**Model Selection**] in the operation monitor screen, and select the model name of the PUMY-series units.
If the model is not listed, press the Cancel button.
In this case, the display function of the refrigerant circuit diagram and Model name is not available.
- When [**Display refrigerant circuit diagram**] in [**Option**] in the main screen is set to [**Inactive**], the [**Model Selection**] tab will not be displayed, and the model name of the PUMY-series units cannot be selected.



- When the refrigerant circuit diagram tab is selected

This tab displays the operation status and the operation data along with a refrigerant circuit diagram.

When the Y/WY series or PUMY series or M-series units are monitored, the tab displays the outdoor units on the left side and the indoor units on the right side of the screen.

When the R2/WR2 series units are monitored, the tab displays the outdoor units on the left side, the BC controllers in the center, and the indoor units on the right side of the screen.



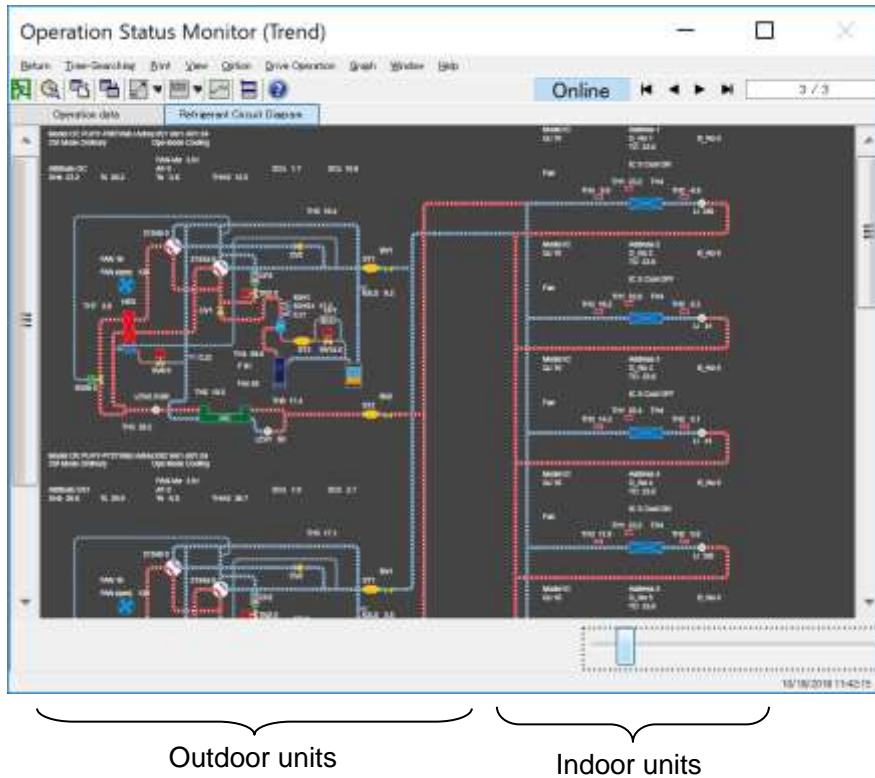



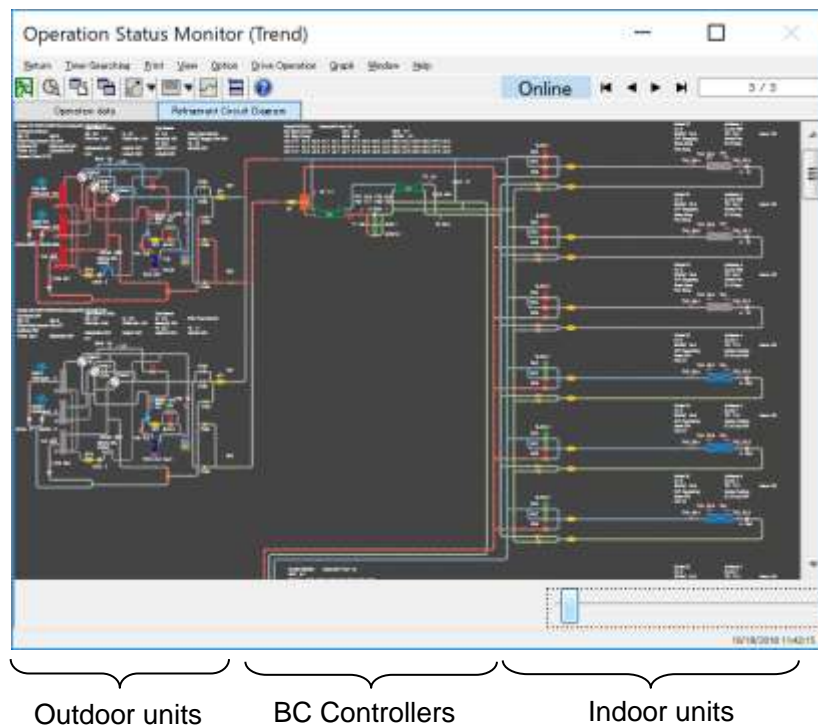

Y/WY series or PUMY series or M-series that switch cooling and heating

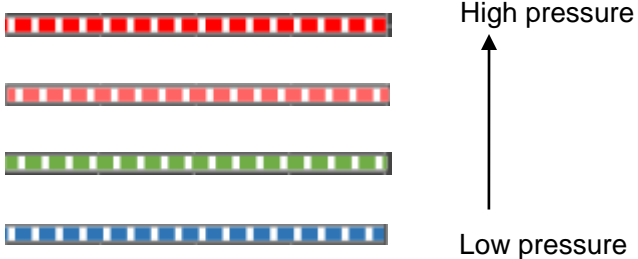

R2/WR2 series that allow simultaneous cooling and heating



In the configuration circuit diagram screen, each part of the unit is displayed in animation or color that represents the following status.

Part	Status
Refrigerant pipe	<p>An animation will be shown of changes in the refrigerant flow according to the pressure.</p>  <p style="text-align: center;">High pressure ↑ Low pressure</p> <div style="border: 1px solid black; padding: 5px; margin-top: 10px;"> <p>Note An animation of the refrigerant flow represents the flow in an ideal pressure condition corresponding to the control mode of the outdoor unit. The actual pressure condition and refrigerant flow may differ from the animation.</p> </div>
Water pipe	<p>The water flow is shown in animation.</p> <p>Red lines show supplied water that flows during heating operation, blue lines show supplied water that flows during cooling operation, and orange lines show circulating water.</p> 
Solenoid valve	<p>The opening status of the solenoid valve is indicated in the following colors.</p> <div style="display: flex; justify-content: space-around; align-items: center;"> <div style="text-align: center;">  Open </div> <div style="text-align: center;">  Closed </div> </div>
Heat exchanger	<p>A color of the heat exchanger changes according to the operation status of the outdoor unit.</p> <div style="display: flex; justify-content: space-around; align-items: center;"> <div style="text-align: center;">  High pressure </div> <div style="text-align: center;">  Low pressure </div> <div style="text-align: center;">  Stopping mode </div> </div>
Fan	<p>An animation of the fan operation status changes as follows.</p> <div style="display: flex; justify-content: space-around; align-items: center;"> <div style="text-align: center;">  Stopped </div> <div style="text-align: center;">  In operation (The fan rotates.) </div> </div>

The refrigerant circuit diagram can be enlarged and reduced by using a slider at the bottom right of the screen.

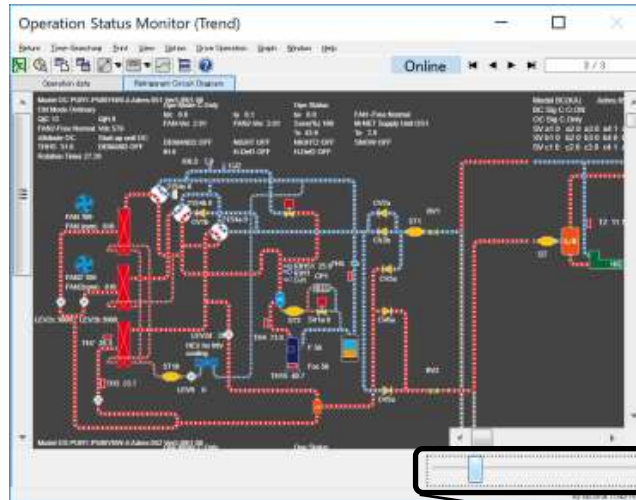

Slider

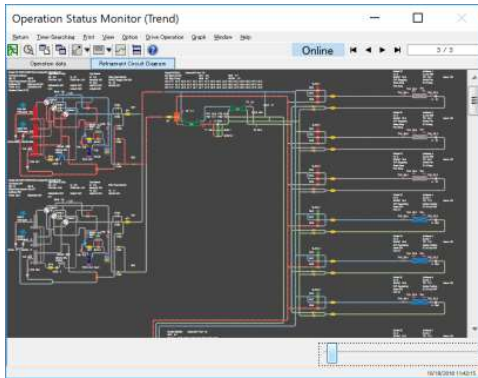

Move the slider to the left to reduce the diagram.

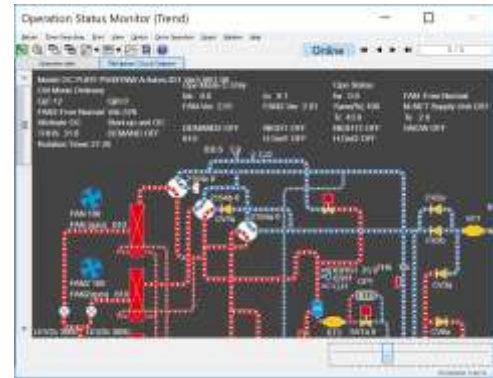

Move the slider to the right to enlarge the diagram.

A scroll bar will appear when the enlarged refrigerant circuit diagram does not fit the screen. Scroll the window to see the rest of the diagram.

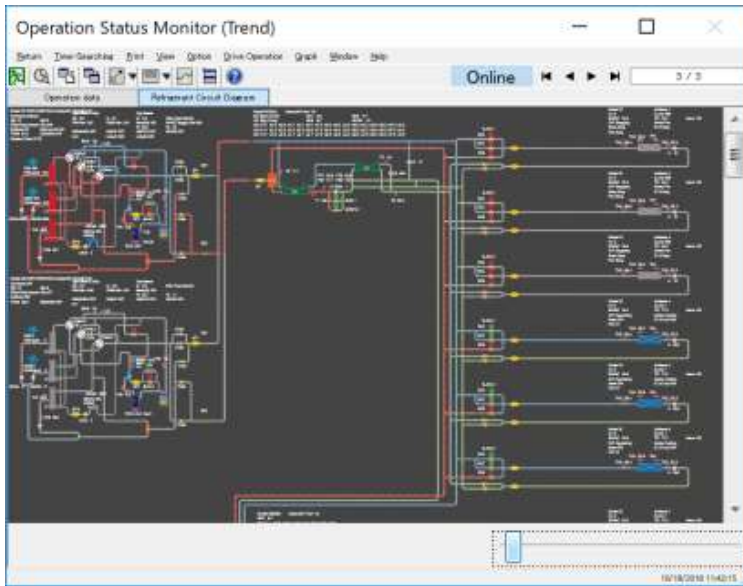

Enlarge the diagram

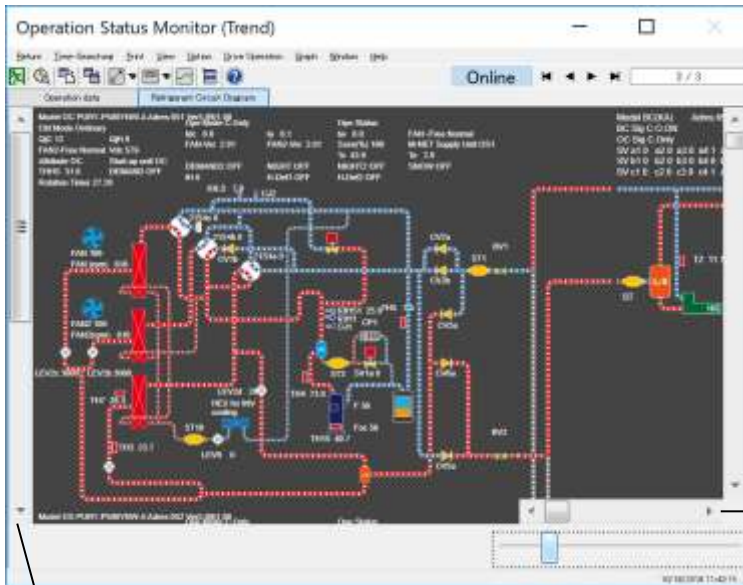

The scroll bar will appear beside the indoor unit area when the Y/WY series or PUMY series or M-series units are monitored, or beside the BC controller and the indoor unit areas when the R2/WR2 series units are monitored.

The screen can be scrolled vertically by using the scroll bar at the right of the screen, and scrolled horizontally by using the scroll bar at the bottom.

The scroll bar will appear beside the outdoor unit area when the diagram is enlarged further.

The screen can be scrolled vertically by using the scroll bar at the left of the screen.

Note

Click the item to see the term explanation.

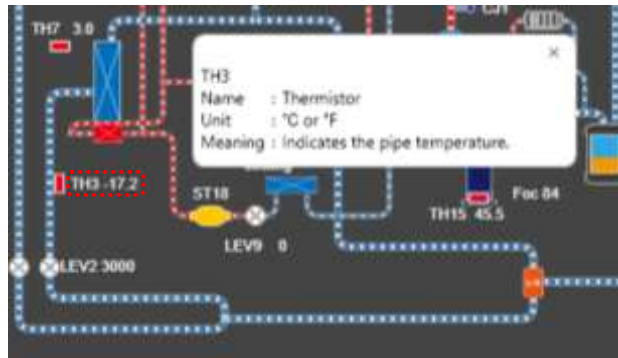

* About LM ADAPTER

Operation Monitor



Item Performed Here

Operation status of LM ADAPTER, current values of network variable and onfiguration property,setting status of switch or the like.

[Refer to 3.7 Operation Monitor]

1. Screen Transfer Operation

To move to the screen monitoring LM ADAPTER operation, select LM ADAPTER from the main screen.

(LM ADAPTER is expressed by)

When LM ADAPTER is selected,you may not monitor other units.

Same operation procedure as that of other units is applicable to other main screens.

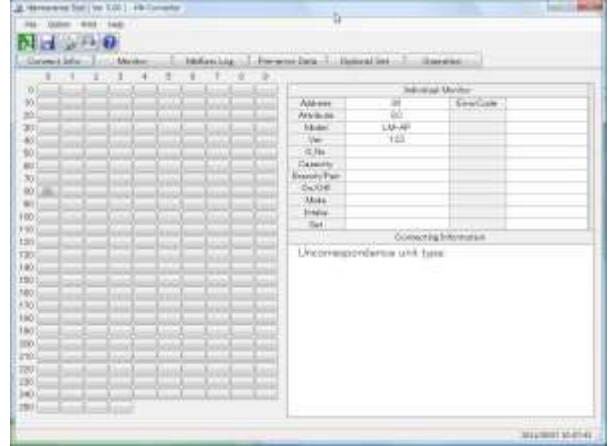

2. Screen Functions and Operations

- The operating condition and operating data are displayed every minute.
- [Current time] will be displayed.During a time when saving data,[Monitor ID] will also be displayed.

[Refer to 5.2 Operation Status Monitor Data.]

(1) [Operation Button]

[Operation control] will not be displayed.

Click on [Return] to end the operation status monitor and return to the Main Screen.

[Refer to 3.7.1(8)]

(2) [Menu Bar]

[Return] , [Print] and [Help] are displayed on the menu bar.

Menus are same as that of other units.

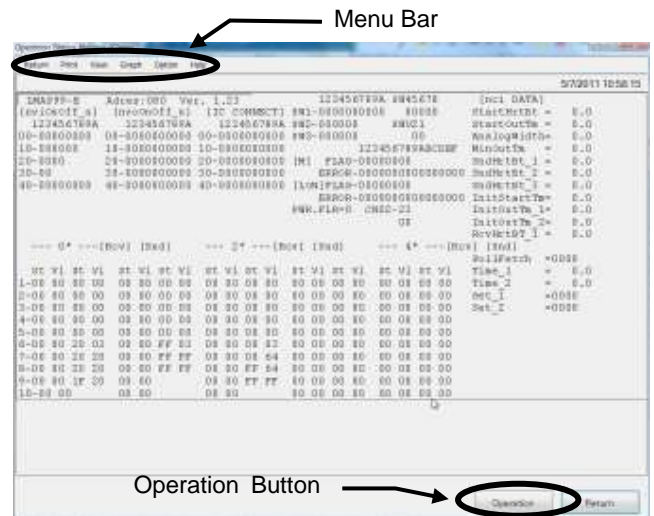

3. Introduction to the screen

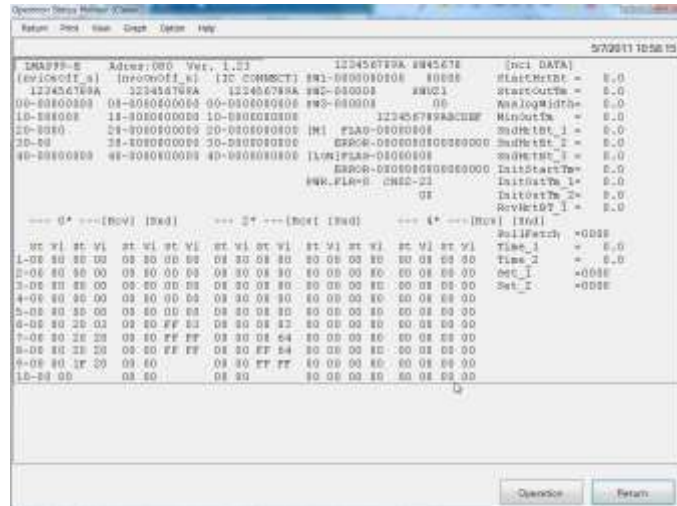

Display	Contents
123456789A SW1-0100000000 SW2-000000 SW3-000000	<Function set switch> Set status of function selector switch 0:OFF setting 1:ON setting
SW45678 00000	<Extension switch> Set status of extension function selector switch 0:OFF setting 1:ON setting
SWU21 49	<M-NET address switch> Set status of M-NET address switch on LM ADAPTER SWU1:The units digit SWU2:The tens digit
123456789ABCDEF [M] FLAG-11000000 ERROR-0011000000000000 [LON]FLAG-00000000 ERROR-0000000000000000	<Control flag> Internal processing status of LM ADAPTER FLAG:Control flag status ERROR:Error flag status [M]:M-NET communication processing flag [LON]:LonWorks communication processing flag 0:Reset 1:Set
CN02-23 11	<General input> General input status of LM ADAPTER 0:Normal 1:Detecting
PWR. FLR=0	<Power failure flag> Indicating power failure detecting status of LM ADAPTER 0:Powering 1:Interrupting
[nviOnOff_n] 123456789A ← Unit address 00-0000000000 (Unit digit) 10-0000000000 ↑ Unit address(Tens digit)	<Binding status : nvoOnOff_n> Binding information on operation command input 0:No binding 1:Binding

Display	Contents																			
<pre>[nvoOnOff_n] 123456789A ← Unit address (Unit digit) 00-0000000000 10-0000000000 ↑ Unit address(Tens digit)</pre>	<p><Binding status : nvoOnOff_n> Binding information on operation status output 0:No binding 1:Binding</p>																			
<pre>[IC CONNECT] 123456789A ← Unit address (Unit digit) 00-0000000000 10-0000000000 ↑ Unit address(Tens digit)</pre>	<p><IC connection status> Connection status of air conditioner(indoor unit) 0:Not connected 1:Connected</p>																			
<pre>--- 0* --- ← Unit address [Rcv] [Snd] (Tens digit) St V1 St V1 1-00 00 00 00 2-00 00 00 00 ↑ Unit address(Unit digit)</pre>	<p><nv Transmitting/receiving data> Latest value of network variables [Rcv] Received value of operation command input [Snd] Output value of operation status St : state field data V1 : value field data</p> <p>Display example</p> <table border="1" data-bbox="724 891 1161 1124"> <thead> <tr> <th rowspan="2"></th> <th colspan="2">[Rcv]</th> <th colspan="2">[Snd]</th> </tr> <tr> <th>St</th> <th>V1</th> <th>St</th> <th>V1</th> </tr> </thead> <tbody> <tr> <td>stopping</td> <td>00</td> <td>00</td> <td>00</td> <td>00</td> </tr> <tr> <td>Operating</td> <td>01</td> <td>C8</td> <td>01</td> <td>C8</td> </tr> </tbody> </table>		[Rcv]		[Snd]		St	V1	St	V1	stopping	00	00	00	00	Operating	01	C8	01	C8
	[Rcv]		[Snd]																	
	St	V1	St	V1																
stopping	00	00	00	00																
Operating	01	C8	01	C8																
<pre>[nci DATA] StartHrtBt =1800.0 StartOutTm =1800.0 AnalogWidth= 1 0</pre>	<p><nci set value> Set value of configuration property</p>																			

3.8.4 Operative Diagnostic Test Function for the SVB on the BC Unit Solenoid Valve Block

- With respect to the information provided in the Service Technical News (SWE12040), diagnostic test is run to automatically determine whether the SVB on the BC unit solenoid valve block is operating normally.
- On the main screen, select the only OC of the system which is the target of diagnosis, and start an operation monitor.
To run diagnostics for multiple systems at the same time, select the OC for each system.
*If the Operation Monitor is started with only an OC selected, the Operation Monitor will monitor operation for all units connected to the selected OC.

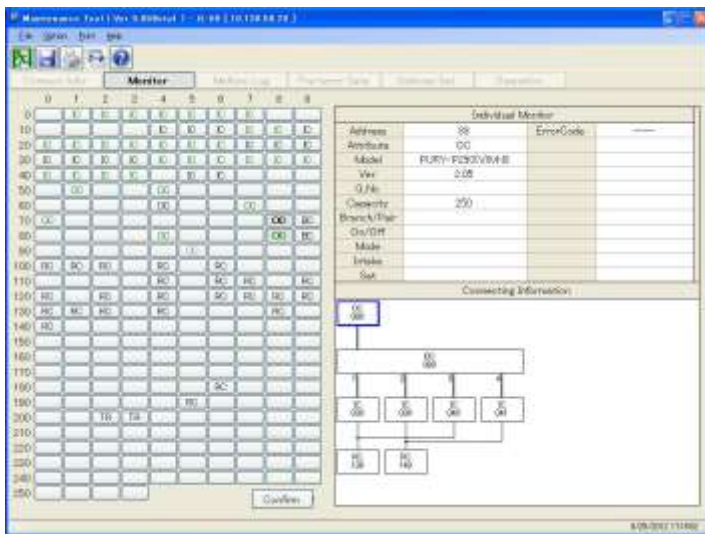

- Check the Operation Status Monitor screen to ensure that all units connected to the selected OC appear.

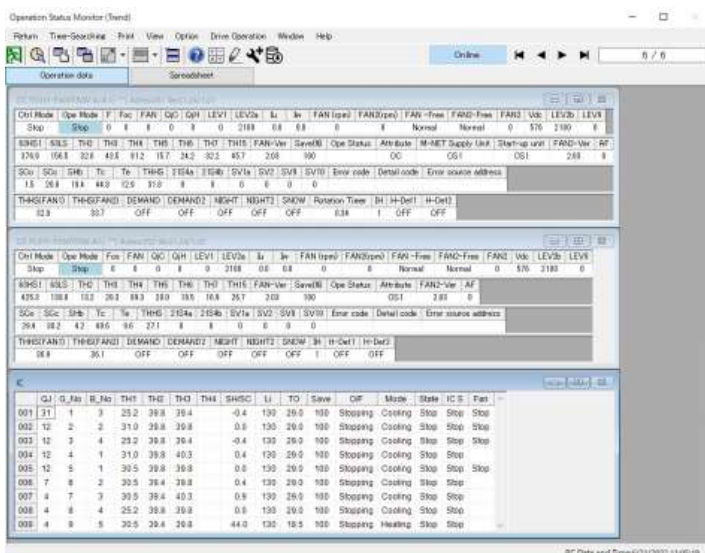

- [BC Auto Diagnosis] button is clicked from the option of a menu bar to open the **[BC Unit Diagnostic Function]** screen.

It will take approximately 30 minutes for the diagnostic test to complete.
Click on the [Start] button to start the BC diagnostic test.



- When all the units connected to OC are not displayed on an operation monitoring screen, the following screens are displayed and diagnosis is not started.



- The screen shown below will appear while the BC diagnostic test is running. Click on the [Cancel] button to stop and exit the BC diagnostic test.

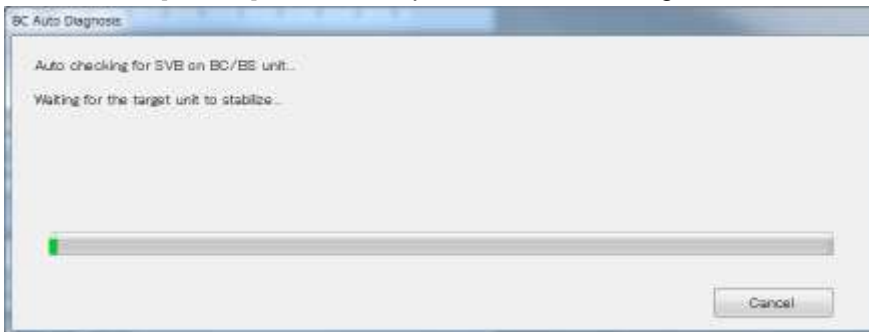

- The test results page appears once the BC diagnostics test has finished.
 - A “OK” result is listed in the Result column for solenoid valves that are operating normally.
 - A “NG” result is listed in the Result column for solenoid valves that are not operating normally.
 - A “—” result is listed in the Result column for solenoid valves that could not be tested properly due to a communications error.
 - A “judgment is impossible “ result is listed in the Result column for solenoid valves that could not be tested properly due to ctrl mode changed to the [stop] or [error] or [defrost] or [off] during diagnosis.
 - A “Diagnosis is interrupted “ result is listed in the Result column for solenoid valves that could not be tested.
- When “Diagnosis is interrupted” fails in the unit stop processing at the time of a diagnostic start, it is displayed.

The results of the diagnostic test are saved automatically.

The name of the file is “BCAutoDiagResult_[Test Date and Time].CSV”, where “Test Date and Time” is replaced with the actual date and time of the test in numeric format.

Click and hold down the [Return] button to end the diagnostic test function.

Once the diagnostic test function has ended, the Operation Monitor data is saved and the Operation Monitor closed.

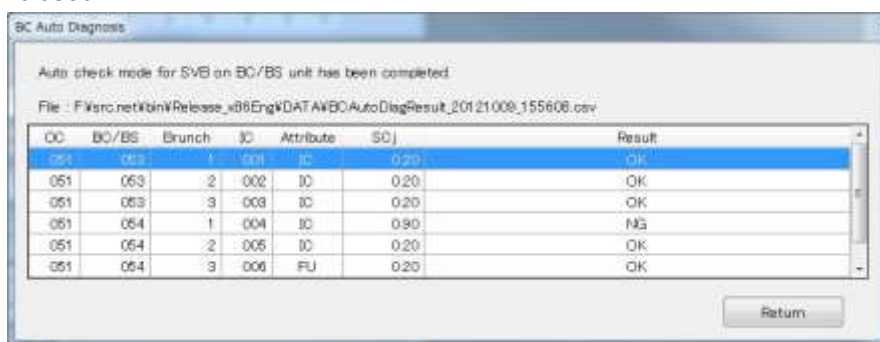

NOTICE

- There are four types of units to be tested, IC, FU, AU and BU.
- Only the solenoid valve of the sub port to which the unit being monitored by the Operation Monitor is connected will be checked during the diagnostic test.
- Once the diagnostic test has ended, make sure to close the Operation Monitor and save the Operation Monitor data.
- The actuators are locked while the BC diagnostic test is running.
Always make sure to use the proper procedures when closing the Maintenance Tool.
If the Maintenance Tool is not closed properly, the actuators will remain in the locked position, which could cause the air-conditioning equipment to malfunction.
- Do not attempt to change the operating status of any of the devices in the indoor units by a remote controller or other means while the diagnostics test is running.
Diagnostic test results may not be accurate if operating status or conditions are changed during the test.
- Turn the Scheduler function OFF if there is a system controller connected.
- Setting of a unit is changed during the diagnosis and it will not switch back to the original setting after the diagnosis is completed.
Write down the settings before starting the diagnosis, if necessary.
IC and FU : Change the operation mode “Heating” and the fan speed “High”.
BU : Change the set temperature 70°C.
*Do not set up the preset temperature limit by the external input of BU
Diagnostic test results may not be accurate.
- Should the diagnostic test end and close out partway through due to the PC freezing, restart the diagnostic test function.

3.9 Optional Setting

Optional Set

*** Items Performed Here**

- **Self-Diagnosis Monitoring** : The self-diagnosis function (LED for service monitor) to be performed with Dip-SW on the circuit board of the outdoor unit can be monitored.
- **Forced Operation** : Changes the starting order of compressors.
- **Sending Command** : Allows to monitor the response for any M-NET command transmitted to the unit.
- **Date / Time Setting** : A setup of the present time can be performed to outdoor unit.
(It is used for the time when abnormalities occurred.)
- **LOSSNAY Function Setting Monitoring** : Monitors function-item settings for LOSSNAY units.
- **Unit Information Writings** : Unit model name and serial number can be written.

(1) Click on **Optional Set** from the function selection buttons on the **Main Screen**.

(2)

(3) Click on the units to be monitored or operated.

(4) The **Optional Setting Screen** will be appear.

Click on **[Item]** to be monitored or operated.

- Click on **Change** and the **Address Change Screen** appears.

[Refer to **3.11.1.1 Malfunction Log 3.11.1.1.1 (5)**]

- The sending/receiving data are displayed on the **[Lower Column]**.

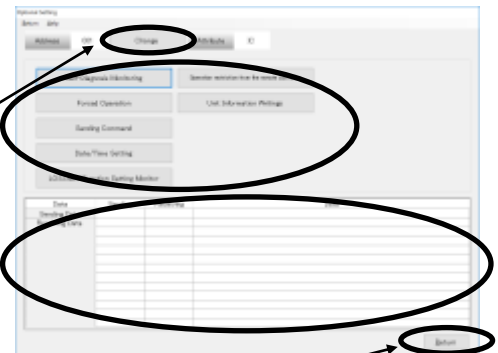

(5) Click on **Return** to end the **Optional Setting Screen** and return to the **Main Screen**.

3.9.1 Self-Diagnosis Monitoring

(1) Click on **Self-Diagnosis Monitoring** and the **Self-Diagnosis Monitoring Screen** will appear.

(2) Set the self-diagnosis SW value with **▲▼**.
For the set value, use the **No. on the List of LED monitor display of the Service Handbook** for each unit.

* The displaying digit number is different on the model.
(There is a model that doesn't display the digit of 1000.)

(3) After setting the set value, click on **Sending**.
The self-diagnosis LED display will be shown with flag or numeral value.

If the unit other than the outdoor unit or the set value being not corresponded is sended, the characters **"Not corresponded"** and **"Attribute and Version"** are displayed.

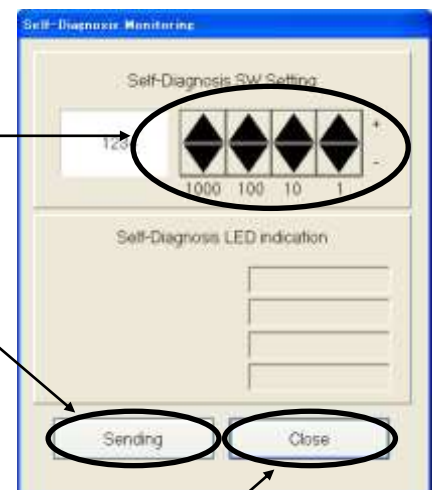

(4) Click on **Close** to end the **Self-Diagnosis Monitoring Screen** and return to the **Optional Setting Screen**.

3.9.2 Sending Command

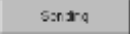
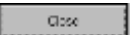
- (1) Click on  and the **Sending Command Screen** will appear.
- (2) Input M-NET command desired to transmit by clicking on the button.
Direct input from the keyboard is also possible.
- (3) After inputting command, click on  .
Response command is displayed on [**Answer**] column.
- (4) Click on  to end the **Sending Command Screen** and return to the **Optional Setting Screen**.



NOTE:

Use this function after obtaining the knowledge of **M-NET** command.

3.9.3 Date / Time Setting

- (1) Click on  . The **Date / Time Setting Screen** opens and the present time of PC is displayed.

* When the unit which does not correspond to a setup of time is chosen, the message of “This function is not available” is displayed, and it cannot set up.

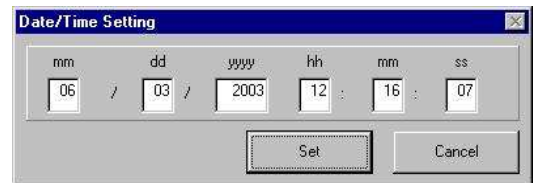

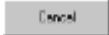
- (2) A click of  sets the time currently displayed to a unit.
* The time to set up can also be changed on a screen. Cursor is united with a change point and a numerical value is inputted.
- (3) Click on  to end the **Date / Time Setting Screen** and return to the **Main Screen**.

3.9.4 LOSSNAY Function Setting Monitor

- (1) In the [Optional Setting] screen, click [LOSSNAY Function Setting Monitor].
The [LOSSNAY Function Setting Monitor] screen appears.
On the [LOSSNAY Function Setting Monitor] screen, the LOSSNAY function setting status can be monitored.

NOTE:

If you selected a unit that does not support the LOSSNAY Function Setting Monitor function, a "This model does not support the LOSSNAY Function setting monitor" message appears.
The LOSSNAY Function Setting Monitor function can only be used for some LOSSNAY models.

- (2) Click [Monitor] to monitor the current set values and display the result on the screen.
- (3) Clicking [Change] opens the [Change] screen.
For operation method, refer to "3.11.1.1 Screen Functions and Operations".
- (4) Clicking [Close] closes the [LOSSNAY Function Setting Monitor] screen.

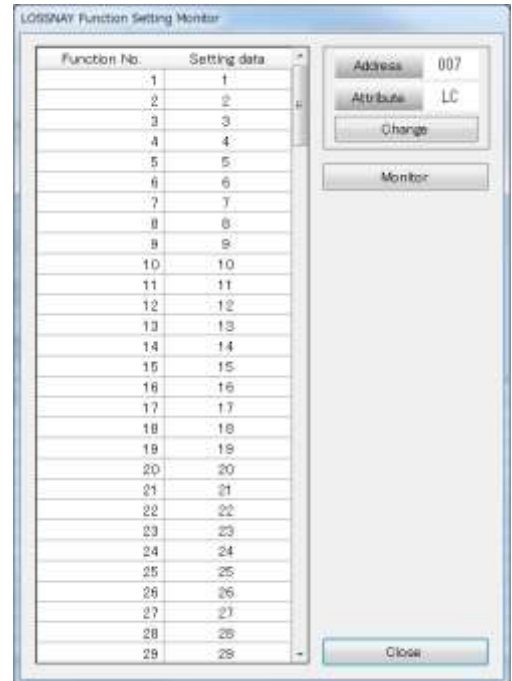

3.9.5 Forced Operation

- (1) On the **[Optional Setting]** screen, click **[Forced Operation]**. The **[Forced Operation]** screen appears.

On the **[Forced Operation]** screen, you can forcefully change the starting order of compressors when starting the air conditioning system.

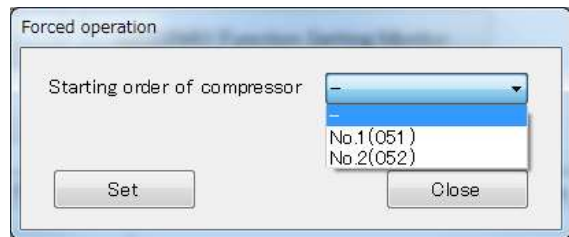

NOTE:

When a unit that does not support the forced operation function is selected, a "**This model does not support the forced operation function**" message appears.



The forced operation function can only be used for some outdoor unit models.

- (2) Click the pull-down menu to display a list of compressors. From the list, select the compressor you wish to start first when the air conditioning system is started.
- (3) Clicking **[Set]** to change the starting order of compressors. After the setting completes, a "**Setting is completed**" message appears.
- (4) Clicking **[Close]** closes the **[Forced Operation]** screen.

3.9.6 Operation restriction from the remote controller

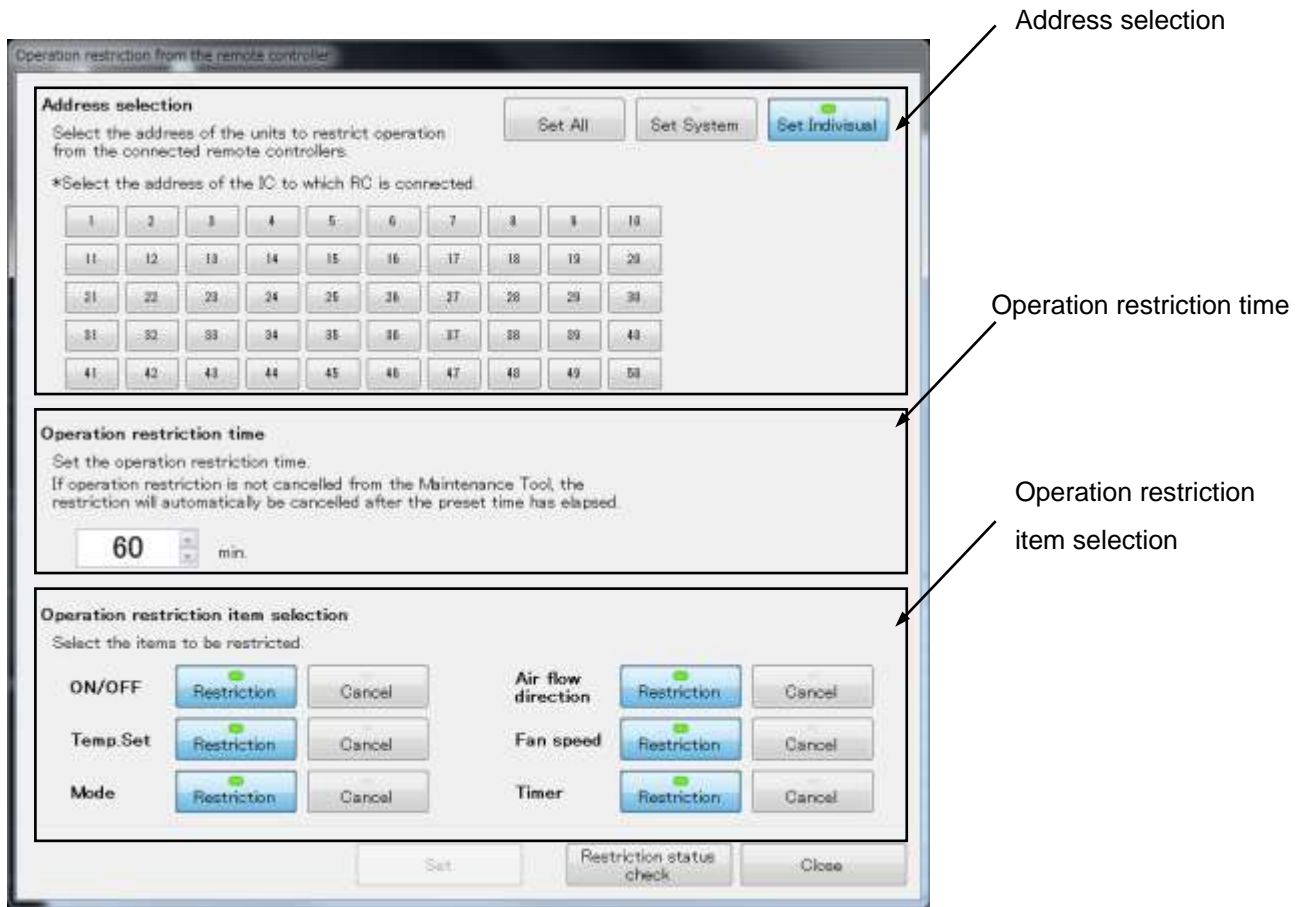
- (1) Click [Operation restriction from the remote controller] on the [Optional Set] window to display the [Operation restriction from the remote controller] window. Using the [Operation restriction from the remote controller] window, the operation from the remote controller can be disabled. To use this function, first set the address selection, operation restriction time, and operation restriction item selection.



Item	Details
Address selection	<p>Select an address to be targeted for the operation restriction. There are three methods of selecting the address: [Set All], [Set System], and [Set Individual].</p> <p>[Set All] When [Set All] is selected, all the remote controllers are selected as targets for the operation restriction.</p> <p>[Set System] When [Set System] is selected, the outdoor unit address can be selected within the range from 51 to 100. Remote controllers that exist in the outdoor unit system of the designated address are selected as targets for the operation restriction.</p>  <p style="text-align: right;">Outdoor unit address selection</p> <p>[Set Individual] When [Set Individual] is selected, the indoor unit address can be selected within the range from 1 to 50. Remote controllers that exist in the indoor unit system of the designated address are selected as targets for the operation restriction.</p>  <p style="text-align: right;">Indoor unit address selection</p> <div style="border: 1px solid black; padding: 5px; margin-top: 10px;"> <p>Note When setting the target address using [Set Individual], select the address of the main unit or of both the main and sub units in the group. If only the address of the sub unit is selected, the operation of the remote controller can not be restricted.</p> </div>
Operation restriction time	Set the operation restriction time. The operation restriction from the remote controller is cancelled after the specified time period has elapsed. The operation restriction time can be set within the range from 10 minutes to 120 minutes.
Operation restriction item selection	Set the operation restriction item. Six operations of ON/OFF, temperature setting, operation mode, air flow direction, fan speed, and timer (restriction of the schedule set by the remote controller) can be restricted.

- (2) After setting the address selection, operation restriction time, and operation restriction item selection, click the **[Set]** button. If there is an unset item, the **[Set]** button is grayed out and cannot be clicked.



Set

(3) The progress bar will appear, and then the confirmation message will appear. Click the **[OK]** button.

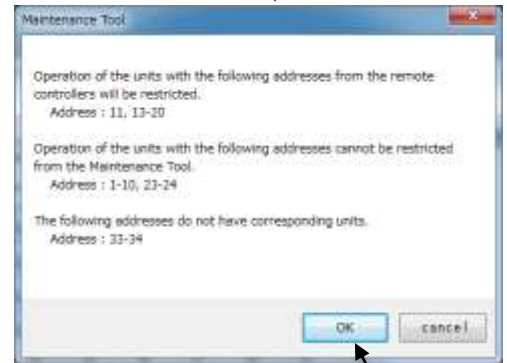
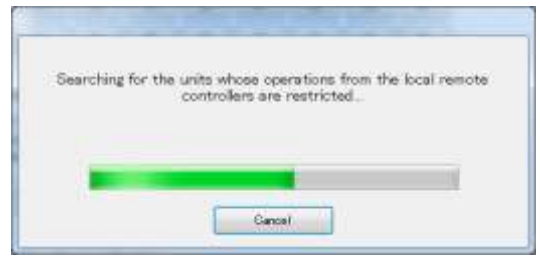

OK

Note

The confirmation message will appear as follows.

Confirmation message	Meaning
Operation of the units with the following addresses from the remote controllers will be restricted.	Appears when the operation restriction can be enabled for the selected address using the Maintenance Tool. When the [OK] button is clicked, the operation of the remote controller connected to the indoor unit having the designated address is restricted.
Operation of the units with the following addresses cannot be restricted from the Maintenance Tool.	Appears when the operation restriction cannot be enabled for the selected address using the Maintenance Tool. Operation from the remote controller cannot be restricted using the Maintenance Tool for some indoor unit models.
The following addresses do not have corresponding units.	Appears when there is no unit in the selected address.

- (4) The Maintenance Tool sends the operation restriction command to the target address. The progress bar will appear, and then the confirmation message will appear.
Click the [OK] button to close the confirmation message.

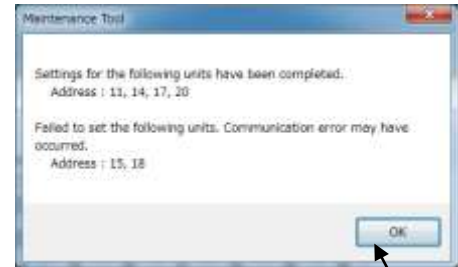

OK

Note

The confirmation message will appear as follows.

Confirmation message	Meaning
Settings for the following units have been completed.	Appears when the operation restriction settings have been made properly.
Setting was cancelled. Settings for the following units have not been completed.	Appears when the [Cancel] button on the progress bar is clicked.
Failed to set the following units. Communication error may have occurred.	Appears when the setting has failed due to a communication error. Check the communication status and make the setting again.

- (5) After completion of the setting, click the [Restriction status check] button.



Restriction status check

- (6) The progress bar will appear, and then the [Operation restriction status] window will appear. The restriction status of each item is displayed on the [Operation restriction status] window. Check that the restriction settings have been made properly. Items being restricted are highlighted in red.



Operation restriction status

Address	ON/OFF	TempSet	Mode	Air flow direction	Fan speed	Timer
001	Cancel	Cancel	Cancel	Cancel	Cancel	Cancel
002	Restriction	Cancel	Cancel	Cancel	Cancel	Cancel
003	Cancel	Cancel	Restriction	Cancel	Cancel	Cancel
004	Restriction	Cancel	Restriction	Cancel	Cancel	Cancel
005	Cancel	Restriction	Cancel	Cancel	Cancel	Cancel
006	Cancel	Restriction	Restriction	Cancel	Cancel	Cancel
007	Restriction	Restriction	Restriction	Cancel	Cancel	Cancel
008	Cancel	Cancel	Cancel	Cancel	Cancel	Restriction
009	Restriction	Cancel	Cancel	Cancel	Cancel	Restriction
010	Restriction	Cancel	Restriction	Cancel	Cancel	Restriction
011	Cancel	Restriction	Cancel	Cancel	Cancel	Restriction
012	Restriction	Restriction	Cancel	Cancel	Cancel	Restriction
013	Restriction	Restriction	Restriction	Cancel	Cancel	Restriction
014	Cancel	Cancel	Cancel	Cancel	Restriction	Cancel
015	Restriction	Cancel	Cancel	Cancel	Restriction	Cancel
016	Cancel	Cancel	Restriction	Cancel	Restriction	Cancel
017	Cancel	Restriction	Cancel	Cancel	Restriction	Cancel
018	Restriction	Restriction	Cancel	Cancel	Restriction	Cancel
019	Cancel	Restriction	Restriction	Cancel	Restriction	Cancel
020	Restriction	Cancel	Cancel	Cancel	Restriction	Restriction
021	Cancel	Cancel	Restriction	Cancel	Restriction	Restriction
022	Restriction	Cancel	Restriction	Cancel	Restriction	Restriction
023	Restriction	Restriction	Cancel	Cancel	Restriction	Restriction
024	Cancel	Restriction	Restriction	Cancel	Restriction	Restriction
025	Restriction	Restriction	Restriction	Cancel	Restriction	Restriction
026	Cancel	Cancel	Cancel	Restriction	Cancel	Cancel
027	Cancel	Cancel	Restriction	Restriction	Cancel	Cancel
028	Restriction	Cancel	Restriction	Restriction	Cancel	Cancel

Different indoor unit models allow for restrictions of different items.
Functions that cannot be restricted are indicated as Cancel restriction

Close

Note

Items that can be restricted vary depending on the indoor unit model. Items that cannot be restricted are displayed as "Cancel" on the [Operation restriction status] window.

- (7) Click the [Close] button to close the [Operation restriction from the remote controller] window.



3.9.7 Unit Information Writings

- (1) Click [**Unit Information Writings**] on the [Optional Setting] screen to display the [Unit Information Writings] screen as shown at right.
- (2) Enter a model name in the [Model] box and a serial number in the [Serial No.] box. Then, click [**Writing**] to write the entered information into the main circuit board.
- (3) Click [**Close**] to end unit information writing and return to the [Optional Setting] screen.



Note

- The [Model] and [Serial No.] boxes are blank when the [Unit Information Writings] screen is displayed.
- Then a unit that does not support the unit information writings function is selected, a message, "This model does not support the Unit Information Writings Function." will appear and the unit information cannot be set.
- To write another unit's information, click [**Change**] to change the target unit address. [Refer to 3.11.1.1 Malfunction Log 3.11.1.1.1 (5)].

Important

- Write unit information when the model name and serial number are unset to a unit (i.e., when the circuit board is replaced).
- After completing unit information writing, check the main screen to see the information has been set correctly. For how to check the information, refer to "3.3 Address Search Method" and "3.4 Main Screen."

3.10 Operation Control

Operation

* Items Performed Here

You can start/stop units and operate the operation mode, set temperature, air volume, damper, humidifier, filter sign reset, and actuator.

The operable range differs depending on the model.

*In the P-series, the item of Damper/Humidifier/actuator can not be operated.

*In the M-series, can not use the Operation Control.

3.10.1 Screen Transfer Operation

- (1) Click on **Operation** from the function selection buttons on the **Main Screen**.
- (2) Click on the unit to be controlled.
- (3) The **Operation Control Screen** will be appear. This display shows the current conditions.

3.10.2 Screen Functions and Operation (Indoor unit, LOSSNAY unit)

- (1) Set each desired **[Item]**.

NOTE:
In case of connecting to P-series with USB/Serial conversion cable, items of (2),(5) are not displayed.

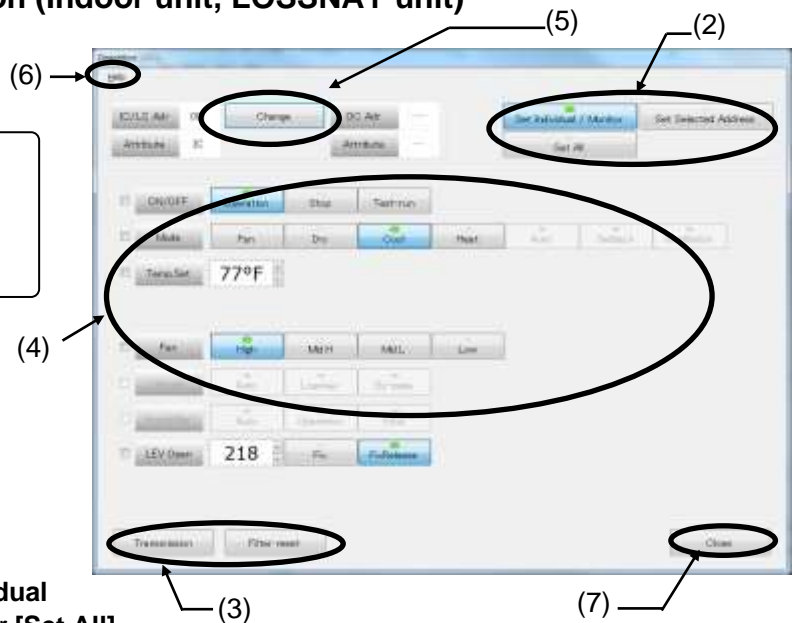

- (2) Set the operation range. Select **[Set Individual Unit/Monitor]**, **[Set Selected Address]**, or **[Set All]** mode.

[Set Individual Unit/Monitor]

Operates the operation status of the selected indoor units.

[Set Selected Address]

When **[Set Selected Address]** is selected, the **[Select Address]** screen appears on the lower right corner of the **[Operation]** screen.

Operates the operation status of the indoor unit of the M-NET address selected using the **[Select Address]** screen.

[Set All]

Operates the operation status of all indoor units that exist.

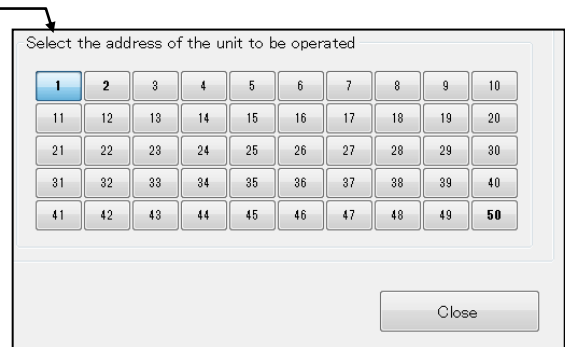

NOTE:

- Using the batch operation for **[Set Selected Address]** and **[Set All]**, four items can be set, i.e. start/stop, operation mode, set temperature, 4-levels of air volume. However, settings that are not supported by the specific model are not sent. (Mode operation for LC, etc.)

- (3) After setting the operation item, click on .
- * The item will not be transmitted if a “check” is removed. Please remove a check if needed.
 - * Click on and the command which resets a filter sign will transmit.
 - * When **[Set Selected Address]** or **[Set All]** is selected, the send targets are searched . After searching, the message screen appears. Click [Yes] to batch send the settings to the targets. Click [No] to not send settings.

(4) The operation mode and temperature settings are set as follows.

Mode

- Fan ... Indoor unit operation mode will be set to the FAN mode.
- Dry ... Indoor unit operation mode will be set to the DRY mode.
- Cool ... Indoor unit operation mode will be set to the COOLING mode.
- Heat ... Indoor unit operation mode will be set to the HEATING mode.
- Auto ... Indoor unit operation mode will be set to the AUTO mode.
Two types of value settings(single set point and dual set points) are available.
(changeable from the function settings menu)
- Setback ... Indoor unit operation mode will be set to the SETBACK mode.

AUTO (dual set point) mode:

In AUTO (dual set point) mode, the preset temperatures can be set for cooling and heating, and operation can be switched automatically between cooling and heating depending on the room temperature.

The preset temperatures for cooling and heating set in AUTO (dual set point) mode will be reflected to the temperature setting for COOL/DRYING and HEAT modes.

NOTE:

- Temperature settings for Cooling and Heating in the AUTO (dual set point) mode can be set to the temperatures that meet the following formula:
“Preset cooling temperature – Preset heating temperature
≥ Minimum temperature difference”
- *If the temperatures for Cooling and Heating are set too close to each other, the temperatures for both the Cooling and Heating will automatically be changed to meet the minimum temperature difference requirement. Minimum temperature difference requirement varies with the indoor unit settings.

SETBACK mode:

The SETBACK function automatically switches the operation mode between cooling and heating to maintain the room temperature within the set temperature range.

The preset temperatures for cooling and heating set in SETBACK mode can be different from the preset temperatures for other modes.

Temperature settings

The method of setting the set temperature differs depending on the indoor unit model.

- If multiple input fields are displayed for the set temperature, it is possible to set the set temperature for each mode of the target indoor units. Set the set temperatures for each mode.
- If multiple input fields for the set temperature are not displayed, it is not possible to set the set temperature for each mode of the target indoor units. Set the set temperatures that is common with different modes.

Mode based setting supported model

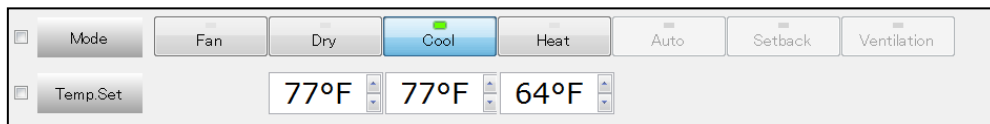

Mode based setting unsupported model



(5) Click on  and the **Address Change Screen** will appear.
[Refer to **3.11.1.1 Malfunction Log 3.11.1.1 (5)**]

(6) **"Menu Bar"**

[Help] appears in the menu bar. Click on **[Help]** and an explanation of the **"Operation Method"** will appear.

[Refer to **3.7 Connecting Information 3.7.2 (2)**]

(7) Click on  to end the **Operation Control Screen**. The **Main Screen** will return.

NOTE:

When LEV OPENING is changed, to prevent failure to release the LEV opening after test run, close the operation control screen. This release the LEV opening on this screen automatically.

However when moving to the operation control screen from the operation monitor screen, the LEV opening will be retained even by closing this screen.

At a timing when finishing the operation monitor screen, the LEV opening can be released.

3.10.3 Screen Functions and Operation (Booster Unit, Water HEX Unit)

Screen when Booster Unit is selected.

Screen when Water HEX Unit is selected.

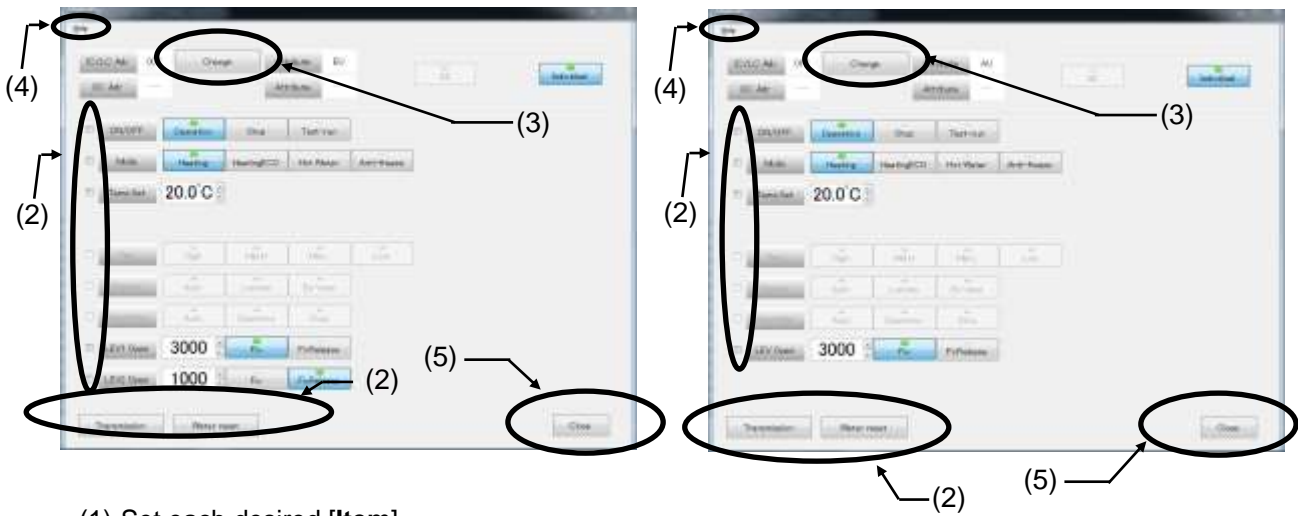

(1) Set each desired **[Item]**.

(2) After setting the operation item, click on **[Transmission]**.

* The item will not be transmitted if a “check” is removed. Please remove a check if needed.

* Click on **[Water reset]** and the command which resets a water exchange signal will transmit.

(3) Click on **[Change]** and the **Address Change Screen** will appear.

[Refer to **3.11.1.1 Malfunction Log 3.11.1.1.1 (5)**]

(4) **“Menu Bar”**

[Help] appears in the menu bar.

Click on **[Help]** and an explanation of the **“Operation Method”** will appear.



[Refer to **3.7 Connecting Information 3.7.2 (2)**]

(5) Click on **[Close]** to end the **Operation Control Screen**. The **Main Screen** will return.

3.10.4 Screen Functions and Operation(BC Controller)

- (1) Click on the button corresponding to the valve number you want to change.
 "0" represents "close" and "1" represents "open".
 To change the valve setting, perform "Fix Release" → "Fix"

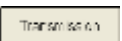

- (2) After setting, click on  .
- (3) Click on  to check the current conditions.
- (4) Change the LEV opening with  . Set to the LEV opening.
 Click on  to send the setup contents.

- (5) After adjustment by solenoid valve and LEV opening change is complete, click on  .
 The **Main Screen** will return. At this time, the contents set at this screen become invalid.

NOTE:
 To prevent failure to release the status set after test run, close the operation control screen of BC/BS controller.
This releases all the content set on this screen automatically.
However when moving to the operation control screen of BC/BS controller from the operation monitor screen,
the set content will be retained even by closing this screen.
 At a timing when finishing the operation monitor screen, the set content can be released.

3.10.5 Screen functions and operation (Hot Water Heat Pump Unit (QAHV))

- (1) Set the addresses.
 Refer to Section 3.11.1.1 Malfunction Log for how to set the addresses. When making the ON/OFF setting for the Hot Water Heat Pump Unit (QAHV), select the main unit (because the setting is made for the entire system and not individual units).

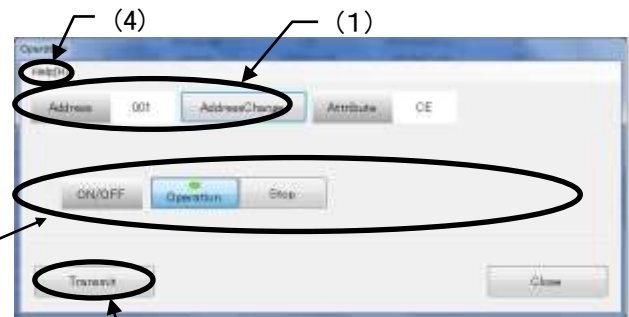

- (2) Set the items to be operated.
 Uncheck the box to exclude items from being sent.
- (3) When done making the settings, click [Send].

- (4) [Menu bar]
 The Help menu is located on the menu bar. Click [Help] to open the Help window.

3.10.6 Screen Functions and Operation(Hydro branch controller)

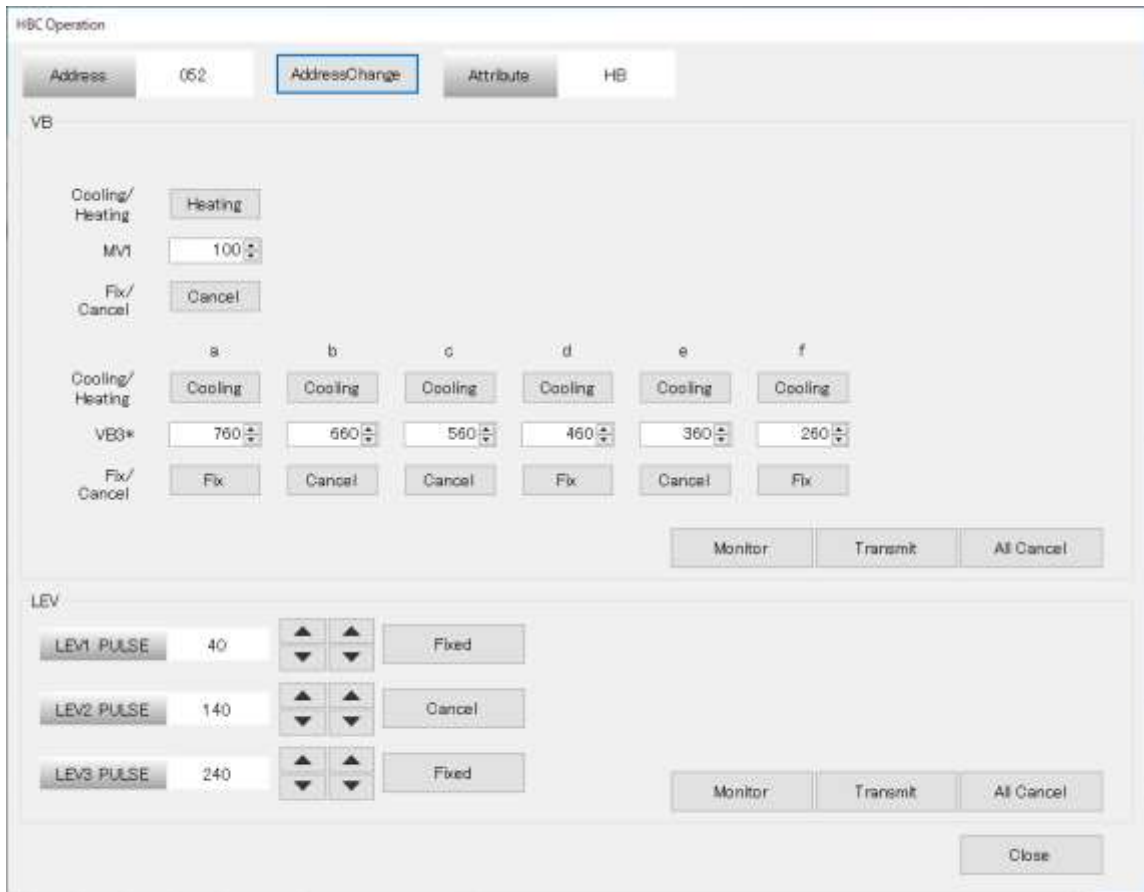

- (1) Change the LEV or Valve opening with [▲▼]. Set to the LEV or Valve opening. Click on [Transmit] to send the setup contents.
- (2) Click on [Monitor] to check the current conditions.
- (3) Click on [All Cancel] to cancel fixation of all actuators.
- (4) Click on [Close] to end the Operation Control Screen. The Main Screen will return.

3.10.7 Screen Functions and Operation(Hydro unit)

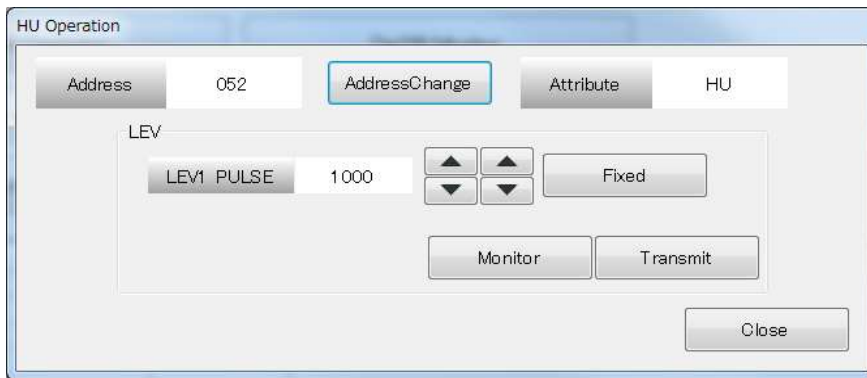

- (5) Click on [**Monitor**] to check the current conditions.
- (6) Change the LEV opening with [**▲▼**]. Set to the LEV opening.
Click on [**Transmit**] to send the setup content.
- (7) Click on [**Close**] to end the Operation Control Screen. The Main Screen will return.

3.11 Maintenance Data

Maintenance Data

* Items Performed Here

- Individual monitoring: Error history and pre-error data can be monitored for each address.
- Download: System information, error history, and pre-error data can be downloaded all at once.

3.11.1 Individual Monitoring

(1) Click the function selection button **[Maintenance data]** on the [Main] screen.
The [Individual Monitor] screen will appear.

(2) Click the data and the address of the unit to be monitored.

(3) Click [Monitor].
Monitor screen will open.
See chapters 3.11.1.1 through 3.11.1.5 for details.

(4) Click [Close] to exit the [Individual Monitor] screen.
The screen will return to the [Main] screen.

Note

- While the addresses are being searched on the [Main] screen, the attributes already found on the [Main] screen will appear on this window.
- If a unit that does not support the function is selected, a message "This model does not support the monitoring of ***" will appear, and the unit will not be monitored.

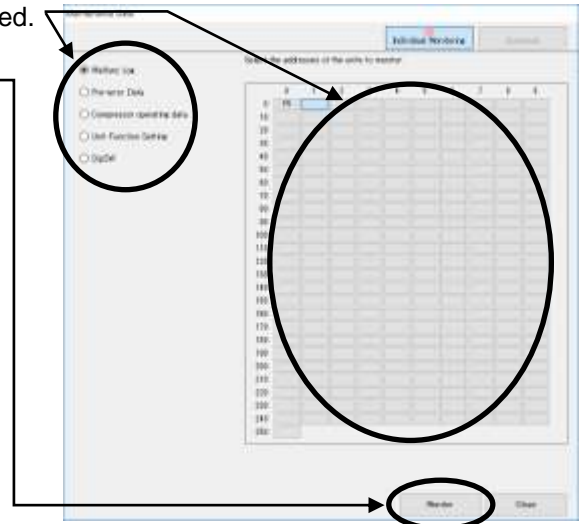

3.11.1.1 Malfunction Log

*** Items Performed Here**

- The malfunction log of the most recent 10 cases (except operation group SC).

3.11.1.1.1 Screen Functions and Operation

(1) Click [Malfunction Log] on the [Individual Monitor] screen, select the units to be monitored, and click **[Monitor]** to view the [Error History].

(2) The message **"Monitoring. Please wait for a moment."** Will appear.

(3) Momentarily, the **Malfunction Log Screen** will appear. If the number of incidents in the malfunction log is less than ten, **[--]** will appear in the attribute column and **[FFFF]** will appear in the code column.

*** Code**

If the error code is displayed in blue, you can view the troubleshooting (PDF document) by clicking the error code

[Refer to **3.4 Main Screen.**]

*** Error detailed No.**

Error detailed No. may be displayed on the right of an error code by the model which carries out a monitor. Refer to the service handbook for the implications of detailed No.

* When the monitor of the unit with a simple clock function is carried out, the time which malfunction generated, or the time when it was integrated to unusual generating is displayed.

- When the unit has received a setup of time: The time which malfunction generated is displayed.
- When the unit has not received the setup of time: The addition time from a power supply injection when malfunction occur is displayed.

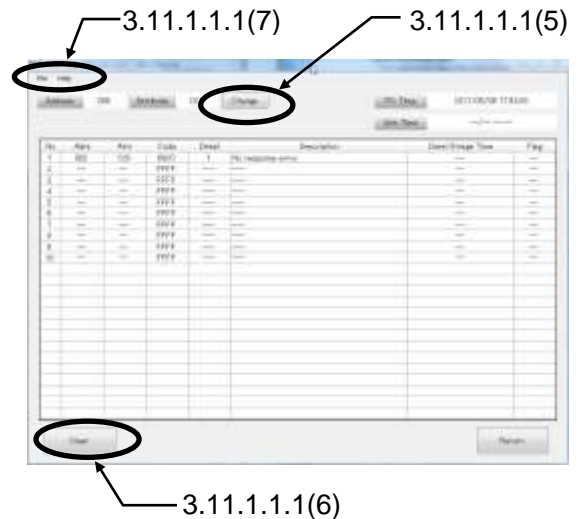

NOTE:

While the power supply of a unit turns off, time does not count the simple clock function of a unit. Therefore, the display of the time which malfunction generated, and addition time will be a mere rough standard.

Whether the power of the unit turned off or not can be checked on the flag display.

*** About a flag display**

- When a flag is "1" : The state which the power supply does not turn off after receiving a setup of time.
- When a flag is "0" : A setup of time is not received. Or the state which the power failure generated after receiving a setup of time.

* About PC Time/Unit Time

- PC Time : The present time set as the Maintenance Tool PC.
- Unit Time : The present time which carried out the monitor from the unit with a simple clock function.

NOTE:

When the system controller which transmits a setup of time to a unit periodically is not connected, a year and moon data are not updated. In this case, the date column of unit time maybe counted up till the 9999th.

(4) Click on to end the **Malfunction Log Screen**.

The message "**Close the malfunction log display?**" will be displayed.

Click on to end or click on to not end.

is clicked, the **Main Screen** is returned.

NOTE:

When Centralized Controller is connected to the system, the malfunction log of OC is eliminated. Please check the malfunction log in Centralized Controller to check the malfunction log of OC.

(5) Click on and the **Address Change Screen** appear.

Click on to change the address.

The unit attributes are displayed at this time.

(If there is no unit at the address given, the attributes are not given.)



Once the address has been set, click on .

The units are changed.

If there is no unit at the address given, the message "**Unit doesn't exist in this address. Retry again.**" Will appear.

Click on to return to the **Address Change Screen**.



(6) Click on and the message "**Clear the malfunction log. Is it OK?**" will appear.

Click on to clear or click on to not clear.

(7) "**Menu Bar**"

The menu bar displays **[File]** and **[Help]**.

- By clicking **[File]** and then selecting "**Save as ...**" from the sub-menu, the Malfunction Log data will be output and saved in the CSV format. This data can not be viewed on the offline screen.

- Click on **[File]** and then select "**Return**" from the sub-menu to end the **Malfunction Log Screen** and return to the **Main Screen**.

- Click on **[Help]** and an explanation about "**Terminology**" and "**Operation Method**" will be appear. [Refer to 3.7.1 Connecting Information of outdoor units 3.7.1.2 (2) "Menu Bar"]

* The error history being memorized by Centralized Controller can also be monitor-displayed.

(Display can not be performed when connecting with MN Converter.)

The system controllers other than Centralized Controller can not provide the monitoring of error history.

3.11.1.2 Pre-error Data

*** Items Performed Here**

- The operation status of the unit (OC/OS) until generating an error can be monitored in a unit of minute.

3.11.1.2.1 Screen Functions and Operation

- (1) Click [Pre-error Data] on the [Individual Monitor] screen, select the units to be monitored, and click [Monitor] to view the [Pre-Error Data] screen.

- When it chooses except the outdoor unit or constant speed unit (OS), the message of **“This model doesn’t have the function of Monitoring of Pre-error.”** Is displayed not allowing operation.

- (2) As the screen opens, the monitoring of the data of the selected unit before error occurred will automatically be started.

- (3) After ending the monitoring, the data of the selected unit before error occurred is displayed in a unit of minute on **Pre-error Data Screen.**

Each figure on the upper column indicates a number of minute before generating an error respectively. The change of the display content is performed with Up/down, left/right scroll bar.

The number of displayed items and that of the stored data (per minute) differ depending on the selected item.

Item	1	2	3	4	5
Indoor T	19.4	19.4	19.4	19.4	19.4
Outdoor T	20.4	20.4	20.4	20.4	20.4
Indoor H	55.0	55.0	55.0	55.0	55.0
Outdoor H	55.0	55.0	55.0	55.0	55.0
Indoor W	1.0	1.0	1.0	1.0	1.0
Outdoor W	1.0	1.0	1.0	1.0	1.0
Indoor Fan	100	100	100	100	100
Outdoor Fan	100	100	100	100	100
Indoor Temp	19.4	19.4	19.4	19.4	19.4
Outdoor Temp	20.4	20.4	20.4	20.4	20.4
Indoor Humidity	55.0	55.0	55.0	55.0	55.0
Outdoor Humidity	55.0	55.0	55.0	55.0	55.0
Indoor Fan Speed	100	100	100	100	100
Outdoor Fan Speed	100	100	100	100	100
Indoor Error	0	0	0	0	0
Outdoor Error	0	0	0	0	0

Outdoor Unit

Item	1	2	3	4	5
Indoor T	19.4	19.4	19.4	19.4	19.4
Outdoor T	20.4	20.4	20.4	20.4	20.4
Indoor H	55.0	55.0	55.0	55.0	55.0
Outdoor H	55.0	55.0	55.0	55.0	55.0
Indoor W	1.0	1.0	1.0	1.0	1.0
Outdoor W	1.0	1.0	1.0	1.0	1.0
Indoor Fan	100	100	100	100	100
Outdoor Fan	100	100	100	100	100
Indoor Temp	19.4	19.4	19.4	19.4	19.4
Outdoor Temp	20.4	20.4	20.4	20.4	20.4
Indoor Humidity	55.0	55.0	55.0	55.0	55.0
Outdoor Humidity	55.0	55.0	55.0	55.0	55.0
Indoor Fan Speed	100	100	100	100	100
Outdoor Fan Speed	100	100	100	100	100
Indoor Error	0	0	0	0	0
Outdoor Error	0	0	0	0	0

Indoor Unit

(4) "Menu Bar"

The menu bar displays **[Return]** and **[Help]**.

- Click on **[Return]** to end the **Pre-error Data Screen** and return to the **Optional Setting Screen**.

As the screen to save data will appear, change the data name as required and save it. You may enter your comment also.

After saving, return to the Optional Setting Screen.

- Click on **[Help]** and an explanation about "**Terminology**" and "**Operation Method**" will be displayed.

[Refer to **3.7 Connecting Information 3.7.2 (2)**]

Confirm Data Save

Are you sure you want to save?

Data Name : OM20130827_111210

Area : Wakayama, Japan

Customer : 3045

System : 6F-1

Comment :

Monitor the Pre-error data

Monitor the realfunc log

Save Exit Save

3.11.1.3 Compressor operating data

[Refer to 3.17 Compressor operating data monitor]

3.11.1.4 Unit Function setting

* Items Performed Here

- A setup and monitor of a function can be performed to unit.

3.11.1.4.1 Screen Functions and Operation

< IC Function Setting >

(1) Click [Unit Function Setting] on the [Individual Monitor] screen, select the addresses of the units to be monitored, and click [Monitor]. [IC Function Setting Menu] screen appear.



(2) Click [IC Function Setting] on the [IC Function Setting Menu]. [IC Function Setting] screen appear.

(3) Set the values.

(4) Click [Set] to send the input data.

(5) Click [Monitor] to acquire the current settings and display the results.

(6) Click [Save to File] to export the current settings to an external file. External files are saved with the extension “.fsb”.

(7) Click [Load from file] and select an fsb file to import the settings.

(8) Click [Change] to access the [Change address] window. Refer to 3.11.1.1 Malfunction Log 3.11.1.1.1 (5) for how to change the addresses.

(9) Click [Return] to exit the [IC Function Setting] screen.

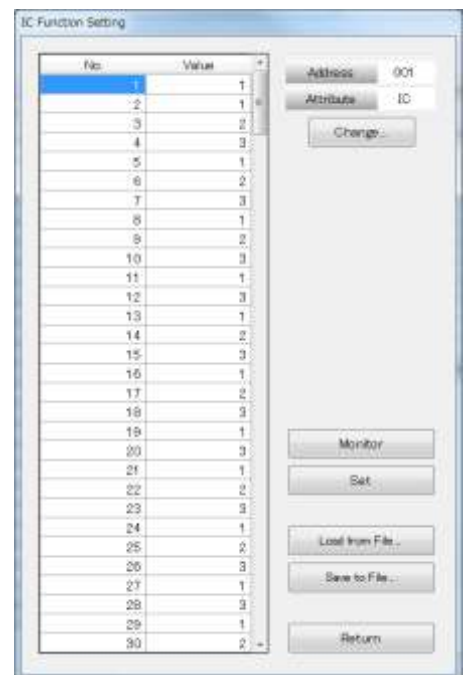

< IC Function-Item Setting >

This function is used to monitor or set the functions of the indoor unit.

- (1) Click [**IC Function-Item Setting...**] on the “IC Function Setting Menu” screen to display the “IC Function-Item Setting” screen.

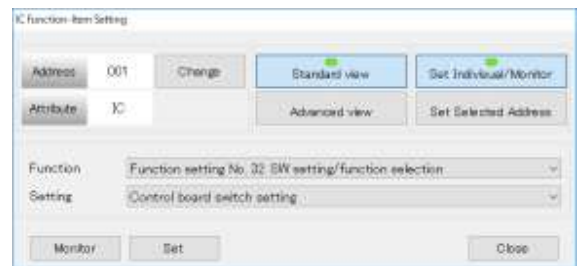
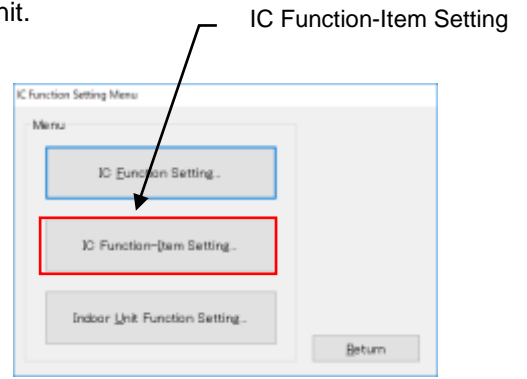

- (2) To check the current function setting of the indoor unit, select the function to be checked in the Function field, and click [**Monitor**].

The current function setting of the indoor unit will be displayed in the Setting field.



- (3) To change the current function setting of the indoor unit, select the item to be changed in the Function and the Setting fields, and click **[Set]**.



Click **[Yes (Y)]** on the confirmation window.

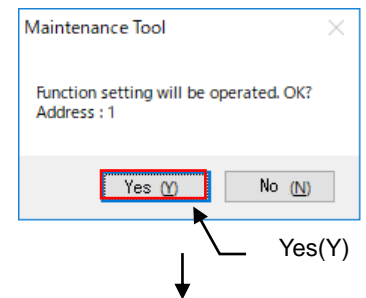

The maintenance tool will change the function setting of the indoor unit. The progress bar appears while the setting is being changed.

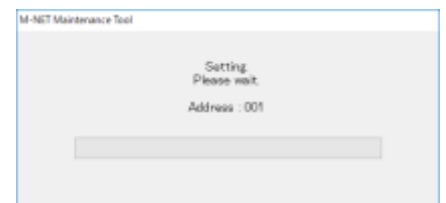

The setting completion window will appear when the function setting of the indoor unit has been changed.

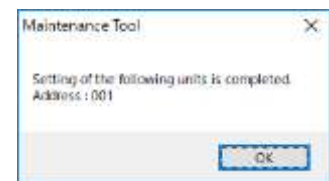

- (4) To check the function setting of the indoor units with other M-NET addresses, click **[Change]** to display the "Address Change" screen. For details, refer to **3.11.1.1 Malfunction Log 3.11.1.1.1 (5)**.

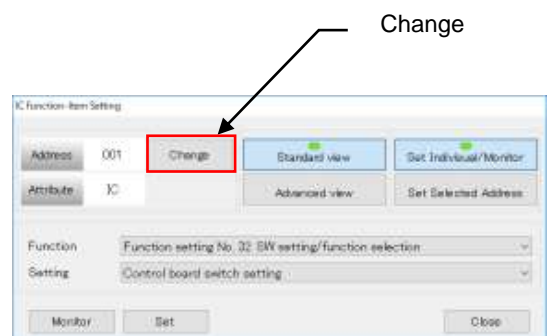

- (5) To collectively change the function settings of multiple indoor units, click **[Set Selected Address]**. The Address Selection window will appear at the right of the screen. Click **[M-NET address]** of the desired indoor units, and click **[Set]**.



The confirmation window will appear. Check the M-NET addresses of the target indoor units, and click **[Yes (Y)]**.

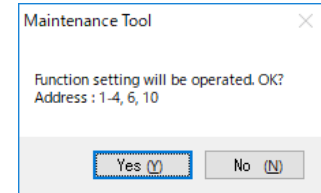

As with the individual setting, the progress bar will appear. To stop changing the setting in midstream, click **[Stop]**.

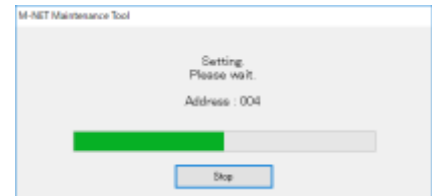

The setting completion window will appear when the function setting of the indoor unit has been changed. When the setting change is stopped in midstream, the completion status of each indoor unit will be displayed with the M-NET address.

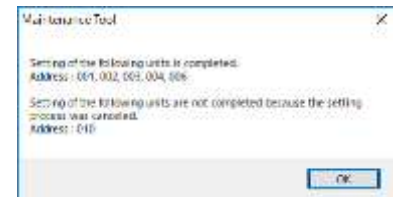

NOTE:
When **[Set Selected Address]** is selected, the **[Change]** and **[Monitor]** buttons are disabled.

- (6) To set the Function and the Setting fields using an arbitrary number (in the text format), click [Advanced view].

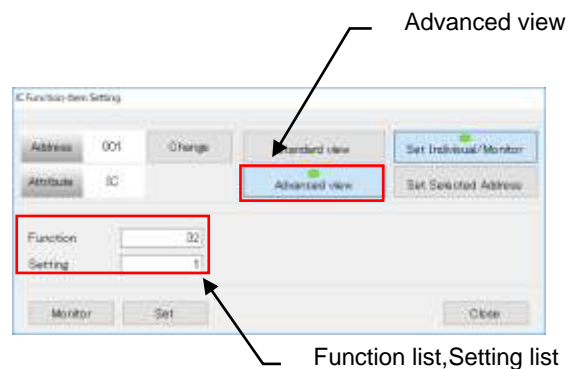

NOTE:

- Use this function only when asked to do so by Mitsubishi Electric.
- Enter any number within the range between 1 and 255 in the "Function" field.
- Enter any number within the range between 1 and 15 in the "Setting" field.

- (7) Click [Close] when the monitoring or setting of the indoor unit function has been completed, and exit "IC Function-Item Setting".



< Indoor Unit Function Setting >

- (1) Click [Unit Function Setting] on the [Individual Monitor] screen, select the units to be monitored, and click **[Monitor]**.
[IC Function Setting Menu] screen appear.



- (2) Click **[Indoor Unit Function Setting]** on the **[IC Function Setting Menu]**. **[Indoor Unit Function Setting]** screen appear. Refer to **[3.16 Setting the Values for Indoor unit Functions]**



<OC(City Multi)>

(1) Click [Unit Function Setting] on the [Individual Monitor] screen, select the units to be monitored, and click [Monitor].

The [OC Function setting] screen will appear.

(2) Click the  button to change the settings for the items in the list.

(3) Click [Set] to send the input data.

(4) Click [Monitor] to acquire the current settings and display the results.

(5) Click [Export] to save the current settings in an external file. External files are saved with the extension “.fsb”.

(6) Click [Import] and select the fsb file to import the monitor results.

(7) Click [Output to Text File] to export the monitor results in a text file in the CSV format. The message will appear that notifies the user of process completion, and the saved file will automatically open.

(8) Click [Change Address] to access the [Address Change] screen. Refer to Item 3.11.1.1 Malfunction Log 3.11.1.1.1 (5) for how to change the addresses.

(9) Click [Close] to exit the [OC Function Setting] screen and go back to the [Optional Setting] screen.

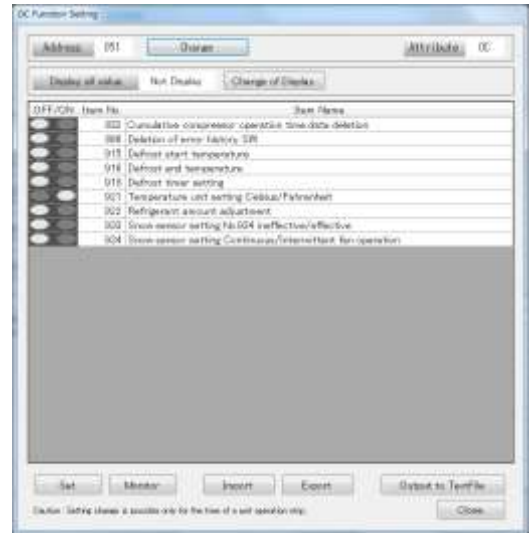

<OC (condensing unit)>

- (1) Click **[Unit Function Setting]** on the **[Individual Monitor]** window, select the M-NET addresses of the condensing units to be monitored, and click **[Monitor]**. The **[Condensing unit setting]** window will appear.

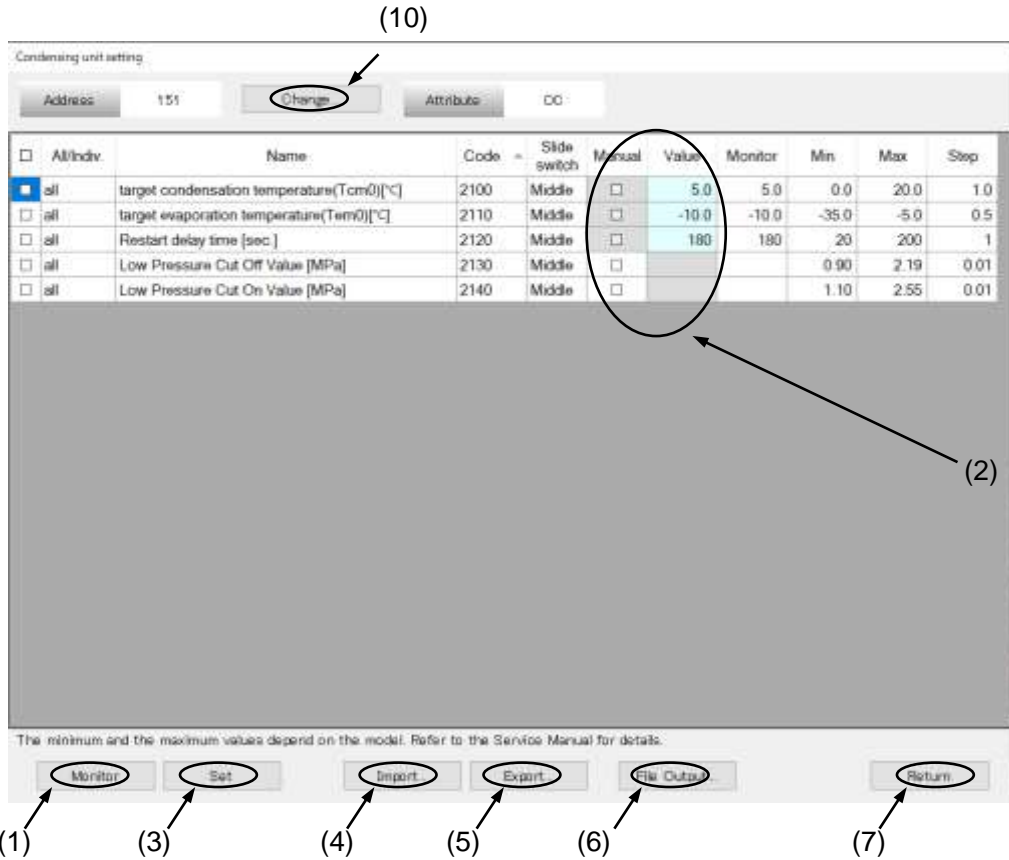

-Monitor-

- (1) When the **[Monitor]** button is clicked, the message “Are you sure you want to monitor the setting?” will appear. When **[Yes]** is clicked, the current setting values will appear in the **[Monitor]** column on the **[Condensing unit setting]** window. Only the items that are selected with the check box on the left side of the window will be monitored.

NOTE:
If data acquisition fails, the message **[Monitor is failed.]** will appear, suggesting that a communication error may have occurred. Check the communication status, and click the **[Monitor]** button again.

-Setting-

- (2) To change the settings of the unit, select the **[Manual]** check box, and enter a value in the **[Value]** column.
To set a threshold, select the **[Manual]** check box, and enter a desired setting value in the **[Value]** column. In the **[Value]** column, enter a value within a range between the **[Min]** value and the **[Max]** value.
Unselect the **[Manual]** check box to automatically set a threshold.

- (3) When the **[Set]** button is clicked, the message “Function settings will be made. OK?” will appear. Click **[Yes]** to apply the values entered in the **[Manual]** and **[Value]** columns to the unit. Only the items that are selected with the check box on the left side of the window will be set.

NOTE:
If data setting fails, the message **[Failed to set the following Code.]** will appear, suggesting that a communication error may have occurred. Check the communication status, and click the **[Monitor]** button again.

-Data import and export-

- (4) Click the [Export] button to export (save) the setting values to an external file. The extension of the external file will be “.set.”
To import (restore) the setting values, click the [**Import**] button, and select a file with an extension “.set.”
- (5) Click the [**File Output**] button to save the setting values in a text format. The extension of the file will be “.csv.”

-Others-

- (6) To exit the [**Condensing unit setting**] window, click the [**Return**] button.
- (7) Click the [**Change**] button. The [**Address Change**] window will appear. Refer to 3.12.1.1.1 (2) in 3.12.1.1 Error History for details.

<CE/CL>

- (1) Click [Unit Function Setting] on the [Individual Monitor] screen, select the addresses of the units to be monitored, and click [Monitor].
[Chiller / Hot water Setting] screen appear.

- (2) Click the [System Setting], [Unit Initialize Setting], [Drive Operation Setting], or [Service Setting] tab on the [Chiller / Hot water Setting] window to change its settings.

Click the [System Setting] tab to set the system settings.

Click the [Unit Initialize Setting] tab to set the initial settings.

Click the [Drive Operation Setting] tab to set the operation mode settings.

Click the [Service Setting] tab to set the maintenance-related settings.

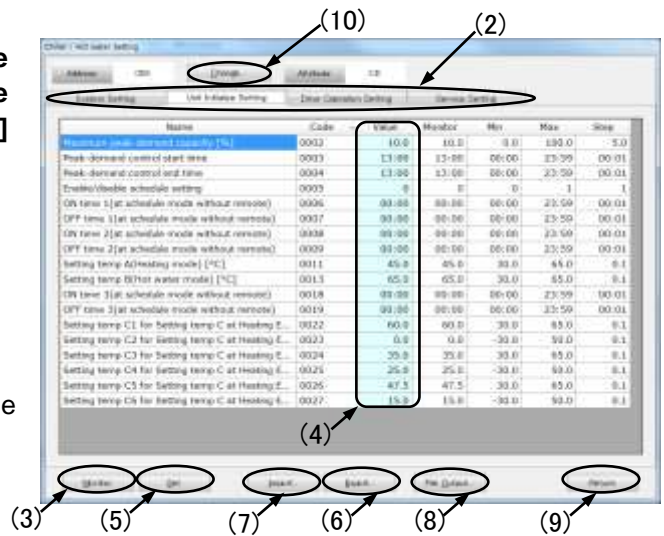

Note

Refer to the Installation/Operation Manual for the details of each setting item.

Not all functions are supported on all models, and nothing will appear on the tabs that correspond to unsupported functions.

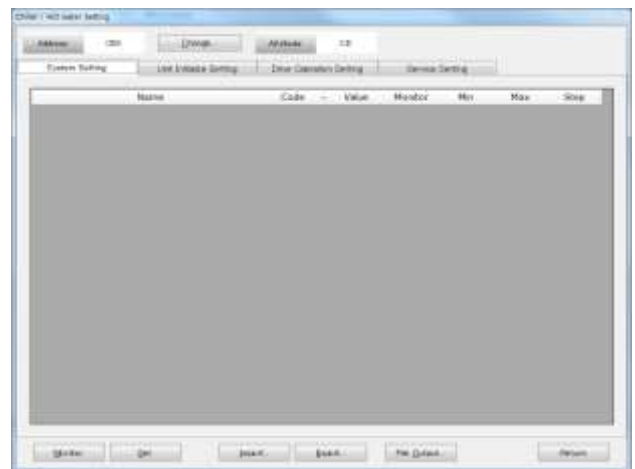

-Monitoring –

- (3) Click [**Monitor**]. The message [**Do you want to start monitoring?**] will appear. Click [Yes] on the popup window to acquire the current setting values and display the results in the [Monitor] value display section.

Note

If data acquisition fails due to a communication error, the message [**Monitor is failed.**] will appear. Check the communication status and try again.

-Settings-

- (4) Enter the setting value for the [Value] column corresponding to each [Name]. The values that can be entered in the [Value] column are the values between the [Min] value and the [Max] value.
- (5) Click [**Set**]. The message [**Do you want to apply the settings?**] will appear. Click [Yes] on the popup window to send the values entered in the [Value] column. The message [**Setting is succeeded.**] will appear upon successful completion of data transmission.

Note

If a setting error occurs due to a communication error, The message [**Setting is failed.**] will appear. Check the communication status and try again.

-Importing/Exporting files-

- (6) Click [**Export**] to save the current settings in an external file. External files are saved with the extension “.set”.
- (7) Click [**Import**] and select a “.set” file to import the settings.
- (8) Click [**File Output**] to save the current settings in a text file (CSV format).

-Miscellaneous items-

- (9) Click [**Return**] to exit the [Chiller/Water heater settings] window.
- (10) Click [**Change**] to access the [Change address] window. Refer to **3.11.1.1 Malfunction Log 3.11.1.1.1 (5)** for how to change the addresses.

3.11.1.5 DipSW Monitor

*** Items Performed Here**

- You can monitor the DipSW.

3.11.1.5.1 Screen Functions and Operation

- (1) Click [DipSW] on the [Individual Monitor] screen, select the addresses of the units to be monitored, and click [Monitor].

DipSW monitor screen appears.

NOTE:

- *Title of DipSW on the circuit board has the difference depending on the model.
- *Please refer to the Conversion-table of help about SWA/SWB.

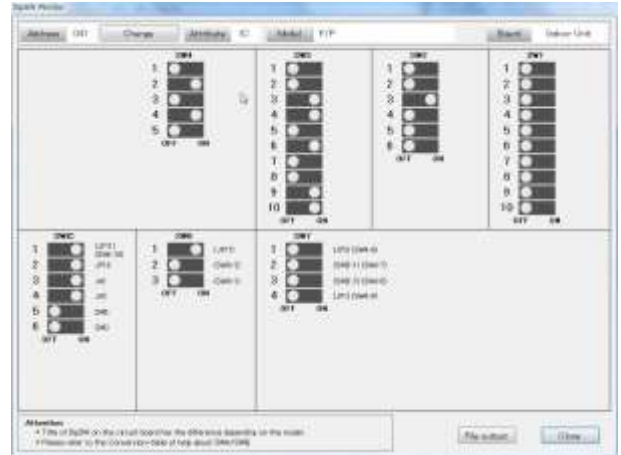

- (2) Click to , the monitoring results to a text file (CSV) file name extension.
- (3) Click on and the **Address Change Screen** appears. [Refer to **3.11.1.1 Malfunction Log 3.11.1.1.1 (5)**]

SWA· SWB Conversion Table			
SWA	Monitor Display	SWB	Monitor Display
1	<p>SW8 2 (SWA-2) 3 (SWA-1) OFF ON</p>	2	<p>SW7 2 (SWB-1) 3 (SWB-2) OFF ON</p>
2	<p>SW8 2 (SWA-2) 3 (SWA-1) OFF ON</p>	3	<p>SW7 2 (SWB-1) 3 (SWB-2) OFF ON</p>
3	<p>SW8 2 (SWA-2) 3 (SWA-1) OFF ON</p>	4	<p>SW7 2 (SWB-1) 3 (SWB-2) OFF ON</p>

3.11.2 Download

(1) Click the function selection button **[Maintenance Data]** on the [Main] screen.
The [Individual Monitor] screen will appear.

(2) Click **[Download]** on the [Individual Monitor] screen.
The [Download] screen will appear.

(3) Click the data and the address of the unit to be downloaded.
A range of addresses can be selected by dragging the mouse.
Click **[Select all]** to select all addresses.
Click **[Deselect all]** to clear all address selections.

(4) Click **[Download]**.
Selected data will be downloaded.

Note

- While the addresses are being searched on the [Main] screen, the attributes already found on the [Main] screen will appear on this window.
- Download of pre-error data from CityMulti outdoor unit takes approximately three minutes per unit.
- Download of other data takes a few seconds to several tens of seconds per unit.
- The time required for download varies with models.

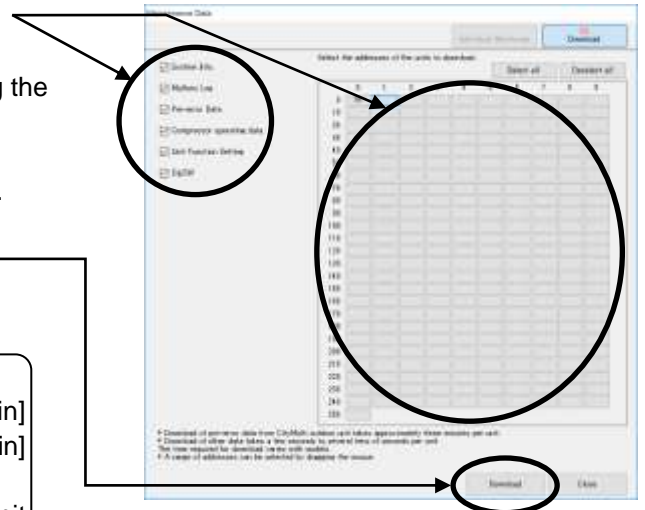

(5) Click **[Cancel]** to stop downloading.

Note
The data downloaded up to the time when [Cancel] is clicked will be stored in the destination folder noted in Step (6).

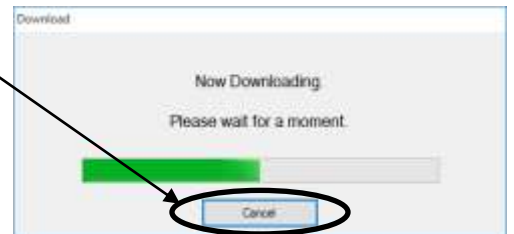

(6) When downloading is complete, "Download completed."

Will appear on the screen.

The data to be downloaded and the storage destination are as follows.

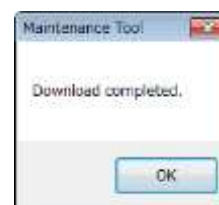

Data	File Name	Storage destination
SystemInformation	SI_YYYYMMDD_hhmmss.MTDZ	C:\MntToolNetEA\Data\YYYYMMDD_hhmmss\SystemInformation
Malfunc Log	ML_YYYYMMDD_hhmmss_***.csv	C:\MntToolNetEA\Data\YYYYMMDD_hhmmss\MalfuncLog
Pre-error Data	<For one pre-error data> <ul style="list-style-type: none"> •PE_YYYYMMDD_hhmmss_***.csv •PE_YYYYMMDD_hhmmss_***.MTDZ <For multiple pre-error data> <ul style="list-style-type: none"> •PE#_YYYYMMDD_hhmmss_***.csv •PE#_YYYYMMDD_hhmmss_***.MTDZ 	C:\MntToolNetEA\Data\YYYYMMDD_hhmmss\Pre-errorData
Compressor operating data	<For chillers> CT_chiller_YYYYMMDD_hhmmss_***.txt <For units other than chillers> CT_YYYYMMDD_hhmmss_***.txt	C:\MntToolNetEA\Data\YYYYMMDD_hhmmss\CompressorOperatingData
Unit Function Setting	UnitFunctionSetting_YYYYMMDD_hhmmss_***.csv	C:\MntToolNetEA\Data\YYYYMMDD_hhmmss\UnitFunctionSetting
DipSW	<ul style="list-style-type: none"> •DipSWMonitor_YYYYMMDD_hhmmss_***.csv •DipSWMonitor_YYYYMMDD_hhmmss_***.jpg 	C:\MntToolNetEA\Data\YYYYMMDD_hhmmss\DipSW

*YYYY: Year; MM: Month; DD: Date; hh: Hour; mm: Minute; ss: Second; ***: Address; and #: Data number

Note

- No comments will be added to the MTDZ file that is downloaded with this function.
- If download fails, a message indicating a download failure will appear. If a unit that does not support the function is selected, an error message including the data and the address of the unit will appear.

(7) Click **[Close]** to exit the [Download] screen.

The screen will return to the [Main] screen.



3.12 OC Date / Time Setting

* Items Performed Here

- A setup of the present time can be performed to all outdoor units at the same time.

3.12.1 Starting of this function

- (1) Screen moving operation and its method
 - a) Clicking [Option] of the menu bar on the main screen and then clicking [OC Date/Time Setting] of the sub-menu. The searching about outdoor unit connected will begin.



NOTE:

When there is no operation object, Warning Message is displayed and processing is interrupted.

- b) The [OC Date/Time Setting] Screen opens and the present time of PC is displayed



3.12.2 OC Date / Time Setting

- (1) The present time of PC is displayed on the [OC Date/Time Setting] Screen in the beginning.
- (2) The time to set up can also be changed on a screen. Cursor is united with a change point and a numerical value is inputted.



- (3) A click of sets the time currently displayed to a unit.

NOTE:

If it failed, Error Message and the error-generated address are displayed.



- (4) When the transmission is completed, Completion Message is displayed.

- (5) Click on to end the [OC Date/Time Setting] Screen and return to the Main Screen.



3.13 Free contact of indoor unit

*** Items Performed Here**

- When utilizing the [Indoor unit free contact mode] which uses the external input/output of Free Plan indoor unit (Building-Multi) together with Centralized Controller and TG 2000A, the contact action of the indoor unit can be tested with this function.

3.13.1 Starting of this function

- (1) Screen moving operation and its method
 - a) Clicking [Option] of the menu bar on the main screen and then clicking [IC free contact ...] of the sub-menu will display the screen for the free contact of indoor unit.

NOTE:
[IC free contact ...] can be chosen only when G-50A is Ver.2.60 or more.

In the case when connected via Centralized Controller, the screen shown right will appear once. Now the necessary information is under collecting from Centralized Controller.



3.13.2 Monitoring of contact status

- (1) Manual monitoring

To manually check the contact status of indoor units at each address, select the [Manual monitor] mode.

 - a) Click the [Manual monitor] button on the mode selection section.
 - b) Click the [Address button] of the unit desired to be monitored. The contact status will be monitored from the unit for display.

[Attribute]

The unit attribute will be displayed.

[Indoor unit contact mode]

The contact mode being set will be monitored, and a check mark will be affixed on the applied mode.

[Input contact (monitor)]

The ON/OFF status of each input contact will be monitored for display.

[Output contact (monitor/operation)]

The ON/OFF status of each output contact will be monitored for display.

In the case of output contacts, the status shown with **bold letter** represents the present status.

Address	Attribute	Free contact	Input 1	Input 2	Input 3	Input 4	Output 1	Output 2	Output 3	Output 4
000	C									
001	C	☑	ON	OFF	OFF	ON	OFF	ON	OFF	OFF
002	C						ON			
003	C									
004	C									
005	C									
006	C									
007	C									
008	C									
009	C									
010	C									
011	C									
012	C									
013	C									
014	C									
015	C									
016	C									
017	C									
018	C									
019	C									
020	C									
021	C									
022	C									
023	C									
024	C									
025	C									
026	C									
027	C									
028	C									
029	C									
030	C									

*In the case of non-objective attribute, and when the contact mode is under normal control, the above monitor display will be [-].

(2) Automatic monitoring

To automatically monitor the contact status of indoor units of No.1 ~ 50 repeatedly, select the [Auto monitor] mode.

- a) Click the **[Auto monitor]** button on the mode selection section.

The contact status of indoor units of No.1 ~ 50 will automatically be monitored, and this operation will be repeated.

The display for [Attribute], [Indoor unit contact mode], [Input contact (monitor)] and [Output contact (monitor/operation)] are identical to that in the manual monitoring.

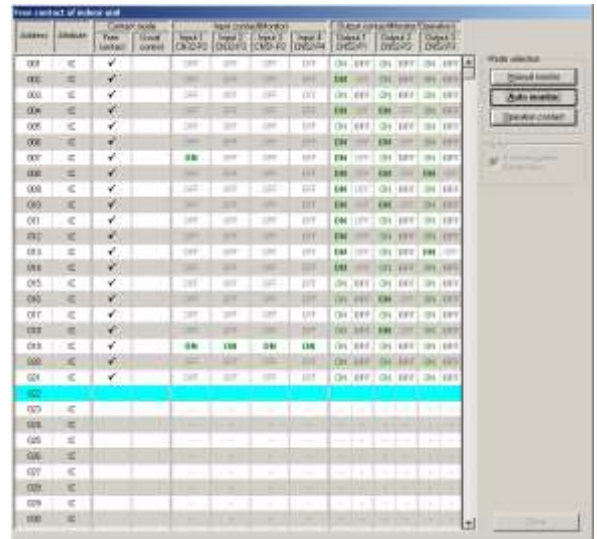

* In the case to terminate the auto mode, selecting other mode will stop the monitoring.

3.13.3 Operation of output contact

(1) Contact operation

To operate for the ON/OFF selection of the output contact of indoor units, select the [Operation contact] mode.

- a) Click the **[Operation contact]** button on the mode selection section.
- b) Click the **[Output contact (ON/OFF)]** button of the unit for which the ON/OFF of the output contact is desired to be selected for change.

***The state where the button is being depressed (with bold letter)** displays the present output status.

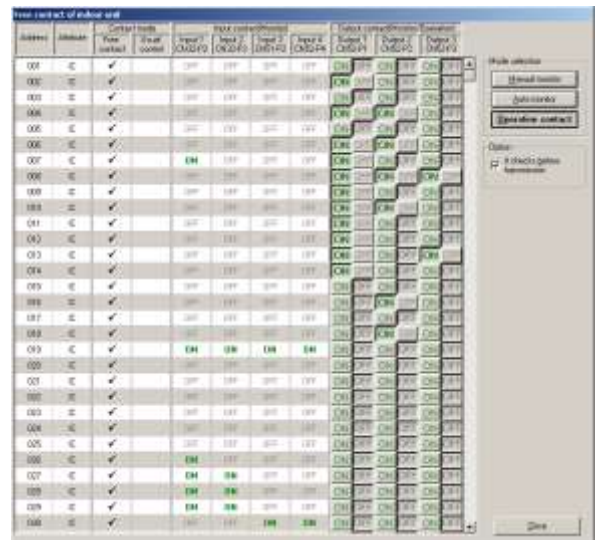

[Option] function

Affixing a check mark to **[It checks before transmission]** displays the warning screen as shown right before transmitting actual transmission command at the operation of output contact. To continue the transmission, click **[Yes]**.

When a check mark is not affixed, the transmission command will be transmitted at the clicking of the **[Output contact (ON/OFF)]** button simultaneously.



3.13.4 Termination of this function

- (1) Clicking the [Close] button will close this screen and return to the main screen display.

3.14 Remote error notification

The “Remote error notification” has been located starting from **Ver4.20**.

* Items Performed Here

- The MN Converter (CMS-MNG-E) has a built-in remote error notification function. When an error occurs in an air conditioning unit, the remote error notification function allows previously registered destinations to be automatically notified of the error via telephone lines. To use the remote error notification function in the MN Converter (CMS-MNG-E), you must first specify the remote error notification settings from the Maintenance Tool.

The MN Converter (CMS-MNG-E) has the following 2 modes:

(2) Maintenance mode

In this mode, the MN Converter can only be used as a normal converter.

(3) Remote error notification mode

This mode allows both the normal MN Converter functions and the remote error notification function to be used.

Use the Maintenance Tool to switch between these 2 modes.

To use the remote error notification function, connect the MN Converter (CMS-MNG-E) to a modem via the RS-232C port and then connect the modem to the telephone outlet, as shown in the figure below. For details, refer to the Installation Manual of MN Converter (CMS-MNG-E). The dedicated server software or other dedicated software Tool run on the remote monitoring PC.

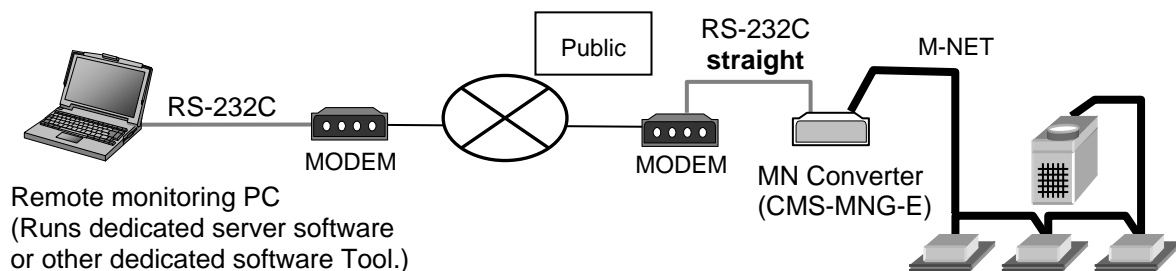

To specify the remote error notification function settings using the Maintenance Tool, connect the MN Converter (CMS-MNG-E) to the Maintenance Tool PC via USB, as shown in the figure below.

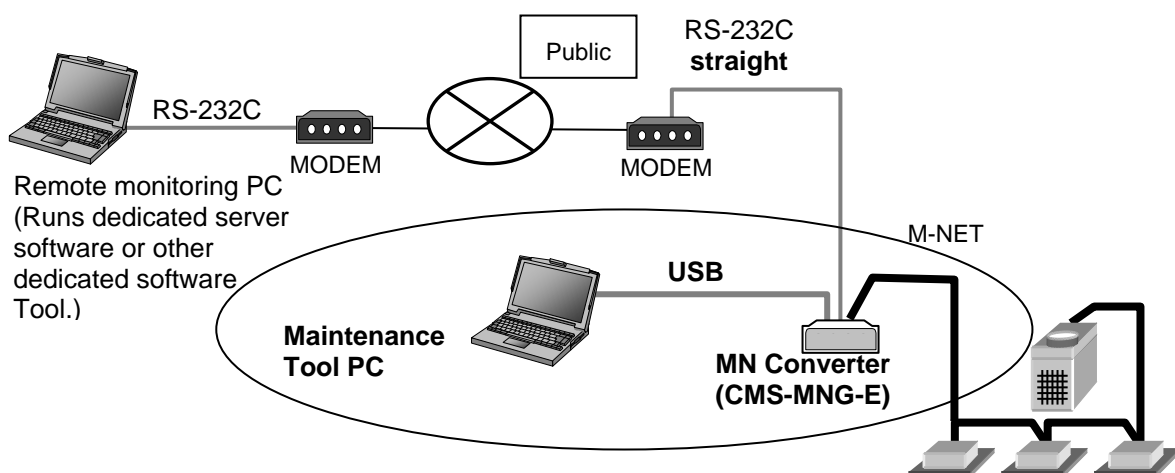

NOTE:

- When setting remote error notification, connect to the MN Converter via USB.

3.14.1 Starting of this function

- (1) Click **[Option]** in the menu bar and select **[Error notification mode] -> [Error notification mode setting/cancellation...]** in the sub-menu.

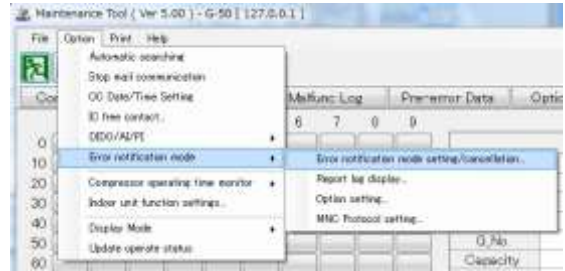

The function starts searching for units to be notified of errors and displays a message to that effect.



- (2) When the search is completed, the **Error notification mode setting/cancellation screen** appears.

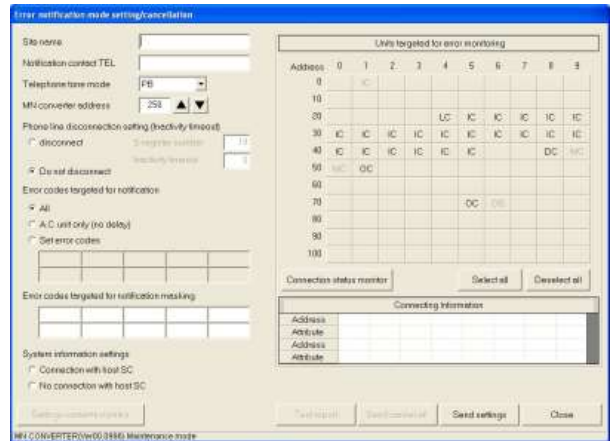

3.14.2 Design of Screen

There are two kinds of following screens to the Error notification mode setting/cancellation screen.

- (1) Maintenance mode -- When the MN Converter is in maintenance mode
- (2) Remote error notification mode -- When the MN Converter is in remote error notification mode

[Maintenance mode screen]

All the settings are blank and the [Settings contents monitor], [Test report] and [Send cancel all] buttons are disabled.

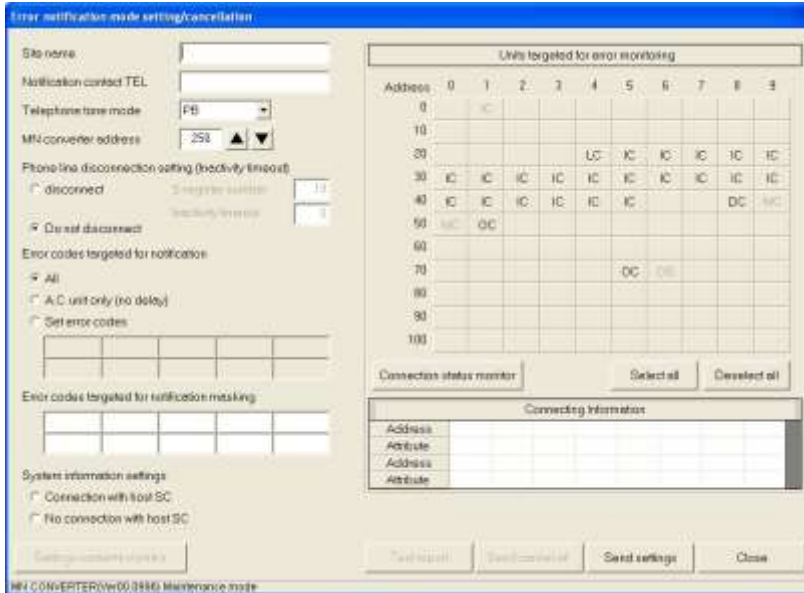

[Remote error notification mode screen]

Monitors and displays the settings from the MN Converter.

If the connection status monitor has not been implemented, “*” appears in the “Units targeted for error monitoring” fields.

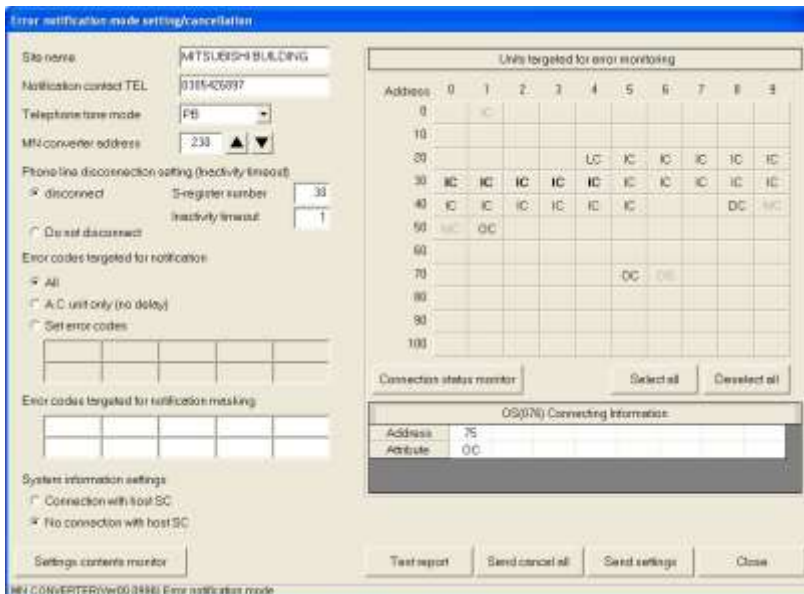

The design of the screen is shown below.

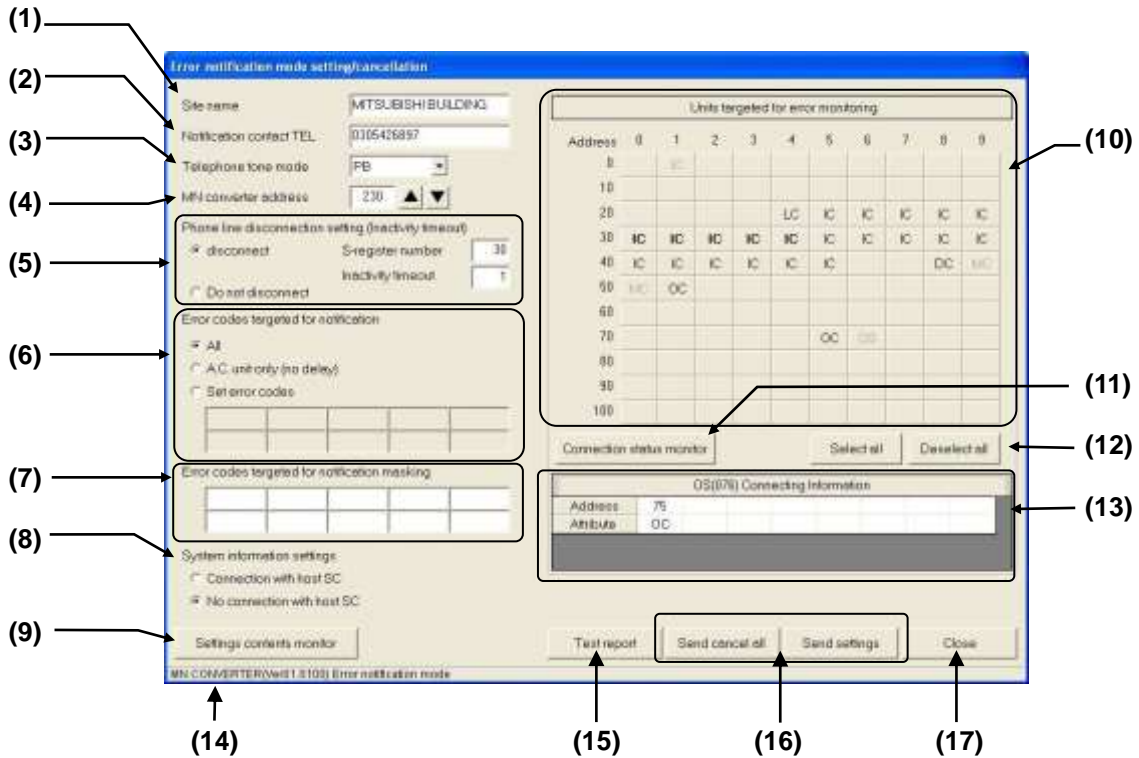

- (1) **Site name**
Name of the system being monitored
- (2) **Notification contact TEL**
Telephone number of the notification contact
- (3) **Telephone tone mode**
Telephone line dial type
- (4) **MN Converter address**
M-NET address of the MN converter
- (5) **Phone line disconnection setting(Inactivity timeout)**
Specifies how soon an inactive telephone line is disconnected.
- (6) **Error codes targeted for notification**
Specifies which errors are notified.
- (7) **Error codes targeted for notification masking**
Specifies the error codes that are not notified (masked) when an error occurs.
- (8) **System information settings**
Specifies whether or not an upstream system controller is connected.
- (9) **Settings contents monitor**
Monitors the MN Converter settings.
- (10) **Units targeted for error monitoring**
Selects the units to be notified when an error occurs.
- (11) **Connection status monitor**
Monitors the connection information for the remote error notification unit.
- (12) **Select all / Deselect all**
Selects or deselects all the units for error notification.
- (13) **Connecting information**
Displays the connection information for the selected unit.
- (14) **MN Converter version/mode**
Displays the version of the connected MN Converter and its current mode.
- (15) **Test report**
Actually calls the notification contacts and sends a test message to test notification operations.
- (16) **Send cancel all/Send settings**
Sends either the settings or a cancel all settings instruction to the MN Converter.
- (17) **Close**
Closes the screen.

3.14.3 Selecting remote error notification mode

Specify the settings below to enable the remote error notification function on the MN Converter.

- (1) Enter the site name.

Enter the name of the air conditioning system to be monitored.

E.g.) MITSUBISHI BUILDING

The remote monitoring PC is notified of this site name.

To enable the remote monitoring PC to monitor multiple air conditioning systems at the same time, you should assign a unique site name to each system.

Site names can consist of up to 20 uppercase letters (A to Z), numbers (0 to 9) and some symbols, but may not contain the following symbols : “ + “ or ” ; “

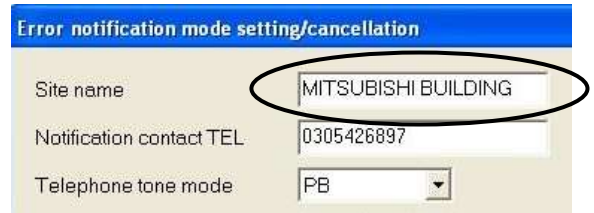

- (2) Enter the notification contact telephone number.

Take care to enter the contact telephone number correctly.

E.g.) For 012-345-6789

Enter the number as 0123456789.

The number cannot include hyphens (-).

Numbers can consist of up to 20 digits (0 to 9). However, when the Inactivity Timeout function is used, numbers may be no longer than 14 digits.

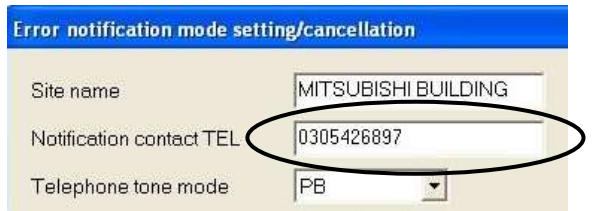

Caution:

Take care to enter the telephone number correctly. If the number contains an error, notification may be sent to an unrelated number and cause problems.

Note that Mitsubishi Electric accepts no liability whatsoever for any problems resulting from incorrect telephone number input.

NOTE:

When select the telephone tone type to “ELSE”, you can enter AT command in this field.

- (3) Select the tone type for the telephone.

Select one of the following telephone tone types:

PB -- Tone (push-button line)
Sends ATDT plus the telephone number to the modem.

DP -- Pulse (dial line)
Sends ATDP plus the telephone number to the modem.

None -- Sends ATD plus the telephone number to the modem.

Else -- Nothing is added to before the telephone number.

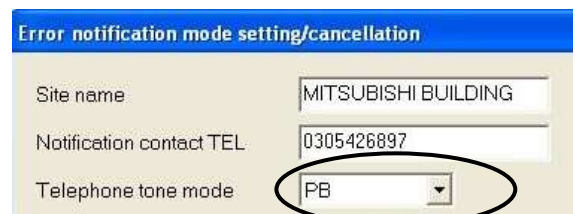

Check your telephone line to determined which tone type is used.

- (4) Enter the MN Converter address.
 Enter the M-NET address for the MN Converter.
 You can enter any number between 201 and 250.
 Ensure that you do not enter the same address as another unit.

The default is 250.

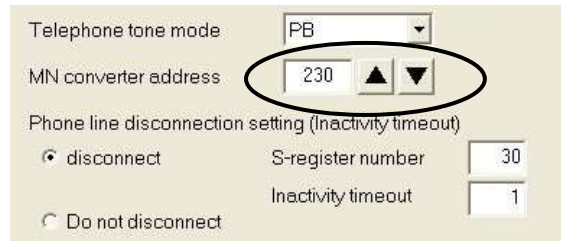

- (5) Specify the setting for the Inactivity Timeout function.
 The Inactivity Timeout function is a modem function that automatically disconnects telephone lines when there has been no communication on a connected line for a set period during error notification.

If power to the MN Converter is turned off due to a power failure or any other cause while a telephone line is connected for error notification, the telephone line remains connected unless this function is enabled.

This function can be used to release connected lines in this situation.

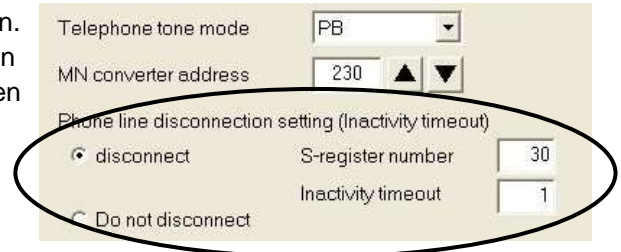

The S-register setting used with the Inactivity Timeout function differs depending on the modem model. **Read the modem's instruction manual carefully to ensure that you use the correct setting.**

- disconnect** Use the Inactivity Timeout function.
- S-register number** Modem S-register number that sets Inactivity Timeout.
- Inactivity timeout** Time for which inactivity is monitored
- Do not disconnect** Do not use the Inactivity Timeout function (default).

Caution:
 If you do not use the Inactivity Timeout function, bear in mind that **telephone lines may remain connected.**
 If you do not use the Inactivity Timeout function, or if the modem settings are not specified correctly, Mitsubishi Electric accepts no liability whatsoever for any faults or damage arising from the continued connection of telephone lines.
Before use, always check that the Inactivity Timeout function is working correctly.

NOTE:
 *The Inactivity Timeout function setting differs according to the modem model.
 (The S-register number and the units and setting range for inactivity timeout differ.)
Read the modem's instruction manual carefully (AT commands) to ensure that you use the correct settings.
 *If the Maintenance Tool is used to remotely connect to the MN Converter via a telephone line while the Inactivity Timeout function is being used, the Inactivity Timeout function may disconnect the telephone line when the Maintenance Tool is not being used.
 If you use the Maintenance Tool to remotely connect to the MN Converter via a telephone line, consider carefully whether to use the Inactivity Timeout function and the length of timeout delay when specifying the settings.
 *When changed this setting, the setting of "Notification contact TEL" is cleared.

(6) Specify the error codes targeted for notification.

You can use this setting to specify which of the errors that occur in air conditioning units will be reported.

You can choose from the following 3 options:

[All]

Reports all error codes.

[A.C. unit only (no delay)]

Error delay codes are not reported.

[Set error codes]

Only the specified error codes are reported.

If you selected **"Set error codes"**, enter the target error codes.

You can specify up to 10 error codes.

You can also specify wildcards. However, if you specify a wildcard in an error code, all the subsequent digits are also taken as wildcards.

Note that you cannot enter a wildcard at the beginning of the code.

- E.g.) 2* -- All error codes from 2000 to 2999
- 2*50 -- Illegal specification.
- **01 -- Illegal specification.

Error codes targeted for notification

All

A.C. unit only (no delay)

Set error codes

Error codes targeted for notification masking

(7) Specify the error codes that will be masked from error notification.

You can use this to specify error codes that will not be reported (that will be masked) when errors occur in an air conditioning unit.

You can specify up to 10 error codes.

You can also specify wildcards. However, if you specify a wildcard in an error code, all the subsequent digits are also taken as wildcards.

Note that you cannot enter a wildcard at the beginning of the code.

- E.g.) 2* -- All error codes from 2000 to 2999
- 2*50 -- Illegal specification.
- **01 -- Illegal specification.

Error codes targeted for notification

All

A.C. unit only (no delay)

Set error codes

Error codes targeted for notification masking

NOTE:

If the error codes targeted for notification and the masked error codes include the same error codes, the message shown below appears.

If there is an overlap, the masking specification has priority.

If necessary, specify the settings again correctly.



- (8) Select the system information settings.
 This option selects whether a host system controller is connected in the M-NET system to which the MN Converter is connected.
 The host system controller is the G-50A, G(B)-50A, or AG-150A, etc.

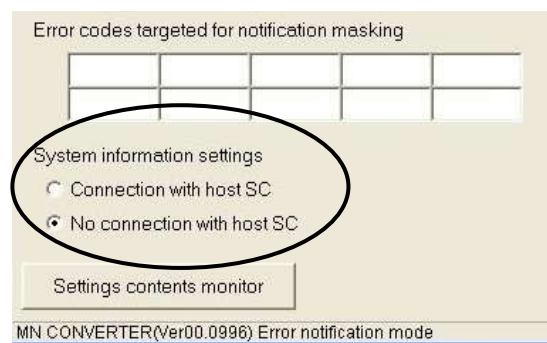

When an error occurs in an air conditioning unit, in order for the unit where the error occurred to notify the MN Converter of the error, the MN Converter address information must first be registered in the unit targeted for notification.

This system information setting (Connection/No connection with host SC) specifies the source from which the address information is registered.

[Connection with host SC]

The MN Converter address information is registered/deleted in the notification target unit from the host SC. (Refer to the host SC instruction manual for details.)



[No connection with host SC]

The MN Converter registers/deletes its own address information in the notification target unit. (To register or delete address information, click **[Send settings]** in this screen.)

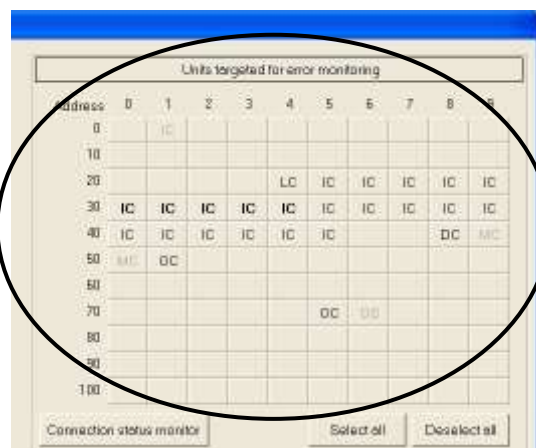
- (9) Specify the units to be monitored for errors.
 Use this to select the units for which notification is provided when an error occurs.
 If a unit is not selected here, no notification is given when an error occurs on that unit.
 When you click a unit, the name is bolded to indicate that it has been selected (will be monitored for errors).
 Clicking the unit name again returns it to normal text and deselects the unit (excluded from monitoring).
 Click the units to be monitored for errors so that they are selected (displayed in bold). To select all the units for monitoring, click **[Select all]**.
 To deselect all the units for monitoring, click **[Deselect all]**.



The meanings of the different types of display are as follows:

- | | | | |
|-------------|---|-------|--|
| Pale gray |  | ----- | There is no error notification function on this model.
This model cannot be selected. |
| Bold |  | ----- | Selected as a unit targeted for error monitoring.
Currently set as a unit to be monitored for errors by the MN Converter or selected ready to be set as such. |
| Normal text |  | ----- | Available for selection as a unit to be monitored for errors.
Not currently set in the MN Converter as a unit to be monitored for errors. |

In addition to the above, units may be displayed in blue. The meaning of this is as follows:

- | | | | |
|------|---|-------|---|
| Blue |  | ----- | Not currently set in the MN Converter as a unit to be monitored for errors, but the MN Converter's connection data is registered in the unit. |
|------|---|-------|---|

- (10) Send the settings.
Click [**Send settings**].

When the **Settings will be sent. OK?** Message appears, click [**Yes**].



Setting begins.



When setting is completed, the **Settings have been sent** message appears.
Click [**OK**].
The MN Converter switches to remote error notification mode.



Caution:

After specifying the error notification settings, always run the error notification test to check that notification is correctly provided to the correct addresses.
[See section 3.14.4].

NOTE:

If you selected "Connection with host SC", you must register the address of the MN Converter on the host SC.

NOTE:

MN Converter is registered with a unit targeted for error monitoring as attribute SC. When five SC is already register with a unit targeted for error monitoring, the following messages are displayed and you cannot register MN Converter with a unit. Please confirm connection relations.



3.14.4 Error notification testing

After setting the MN Converter to remote error notification mode, run the error notification test to check that notification is implemented correctly.

Caution:

After specifying the error notification settings, always run the error notification test to check that notification is correctly provided to the correct addresses during the error notification test, always check that errors are posted correctly on the remote monitoring PC.

NOTE:

Before running the error notification test, check whether the software running on the remote monitoring PC is the dedicated server software or another software tool. Then refer to "3.14.8 Option settings" to ensure that you specify the correct server or Tool settings.

- (1) In the **Error notification mode setting/cancellation screen**, click **[Test report]**.

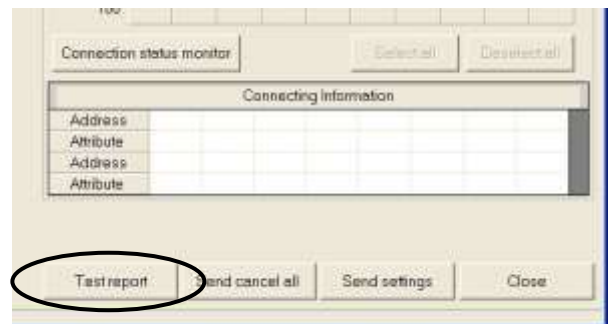

- (2) The test notification begins.
A confirmation window is displayed.
Check the contact number and then click **[Yes]**.

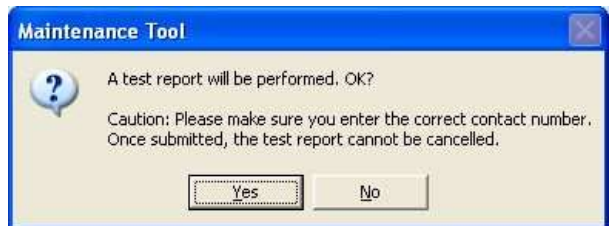

NOTE:

When error notification is in progress, the following messages are displayed, and the test report cannot be performed. Please wait and try again.
In addition, when a modem is not connected, the following messages are displayed.
Please try again after connecting a modem definitely.



- (3) After a few moments, the results are displayed.
Check the message and then click **[OK]**.

[In the case of success]

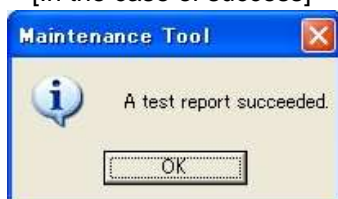

[In the case of failure]

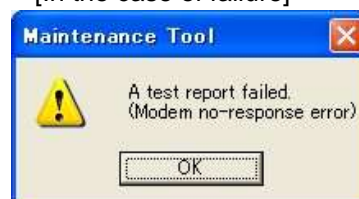

(* The actual message differs depending on the error.)

The error messages are shown below.
If an error occurs, check the connections, etc.

Error message When Test report

Error message	Meaning/Cause	Repair
A test report failed (Modem no-response error)	Modem connection error The MN Converter cannot communicate with the modem. Probable causes are: * The cable between the MN Converter and the modem is not connected properly. * The modem is not turned on.	* Check the connections on the cable between the MN Converter and the modem. * Turn the modem on.
A test report failed (Phone connection error)	Phone line connection error. A call was made via the modem, but no connection with the contact could be established. Probable causes are: * The cable between the modem and the telephone line is not connected properly. * The other party's telephone is not responding. * The contact phone number is wrong. * The telephone line itself is damaged.	* Check the connections on the cable between the modem and the telephone line. * Check that the other party's modem is set to auto receive. * Check the contact phone number. * Check with the connecting telephone exchange.
A test report failed (Server no-response error) * Only when "Server" is selected in "Option settings".	Contact server no-response error. Communication was established with the other party's modem, but there is no response (REP) from the contact server. * The contact server is not connected or the dedicated server software is not running.	* Check the operation status of the contact server.
A test report failed (No-response timeout)	No response from the MN Converter. The software cannot communicate with the MN Converter. * The MN Converter cable is disconnected or broken. * Power to the MN Converter has failed.	* Check the connection to the MN Converter. * Check that the MN Converter is powered up.

(4) Also check that notification is provided correctly on the remote monitoring PC.

For information on the message format used for test notification, see section "3.14.9 Error notification data format".

(5) Click **[Close]** to exit the setting/cancellation screen.

The design of the screen is shown below.

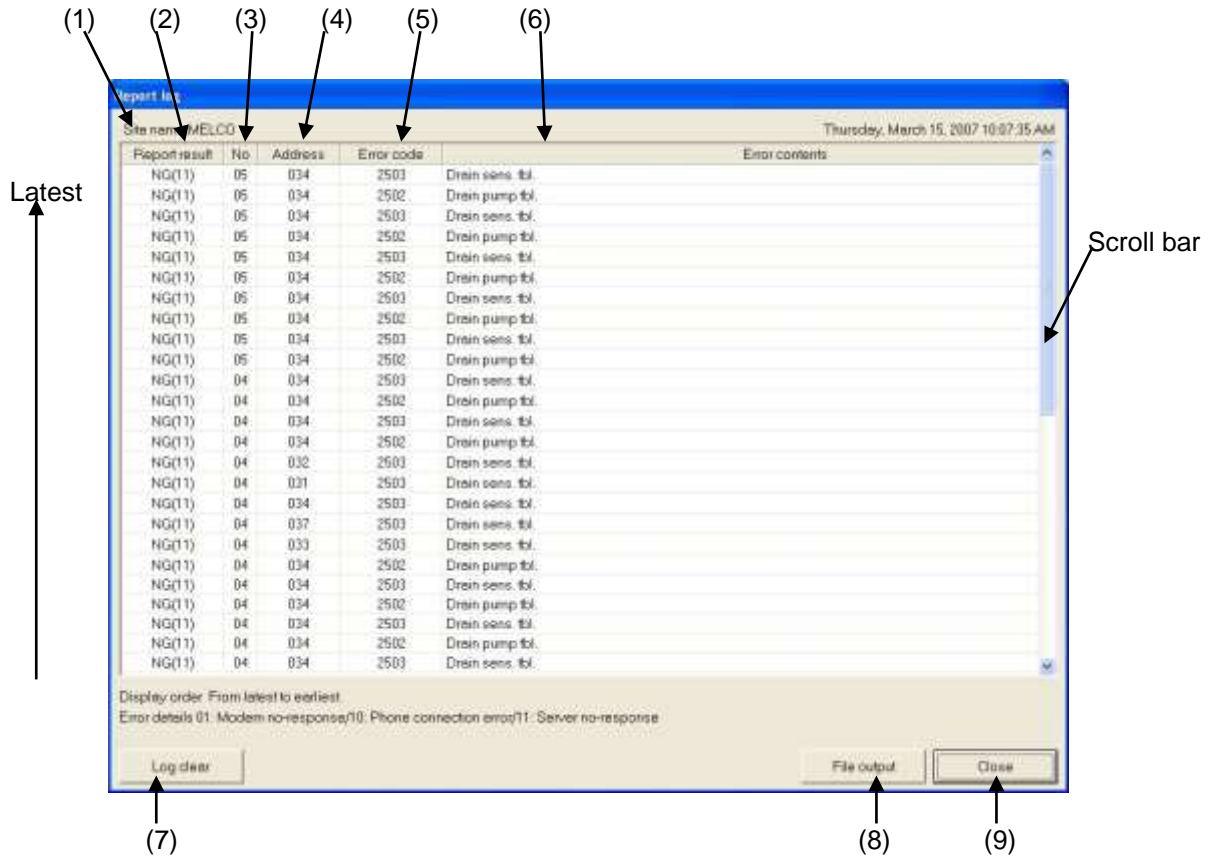

- **(1) Site name**
Name of the system being monitored [see section 3.14.3 (1)]
- **(2) Report result**
Results notified
 - OK** --- Notification succeeded
 - NG(**)** ----Notification failed
 - **** : Error code (see below)
 - 01:Modem no-response -- There was no response from the modem.
 - 10:Phone connection error--A telephone line connection could not be established.
 - 11:Server no-response -- There was no response from the server software.
(Only applies when “Server” is selected in “Option setting” (see section 3.14.8).)
- **(3) No.**
Notification number
A number assigned sequentially for each notification. [See section 3.14.9 for details.]
- **(4) Address**
M-NET address of the unit in which the error occurred.
- **(5) Error code**
Code for the error that occurred.
- **(6) Error contents**
Details of the error.
- **(7) Log clear**
Clears the Report log.
- **(8) File output**
Saves the Report log as a CSV-format file. [See section 3.14.5.3.]
- **(9) Close**
Closes the **Report log screen**.

3.14.5.2 Clearing the Report log

- (1) Click the **[Log clear]** button in the **Report log** screen.

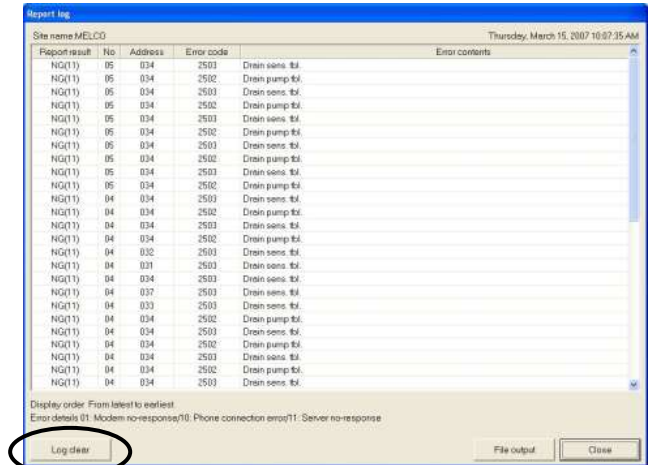

- (2) Click **[Yes]**.



- (3) The Report log is cleared. Click **[OK]**.



NOTE:
When you clear the Report log, the notification number is reset and restarts from 1 in the next report.

3.14.5.3 Saving the Report log in CSV format

You can save the Report log as a CSV-format file on the Maintenance Tool PC.

- (1) Click the **[File output]** button in the **Report log** screen.

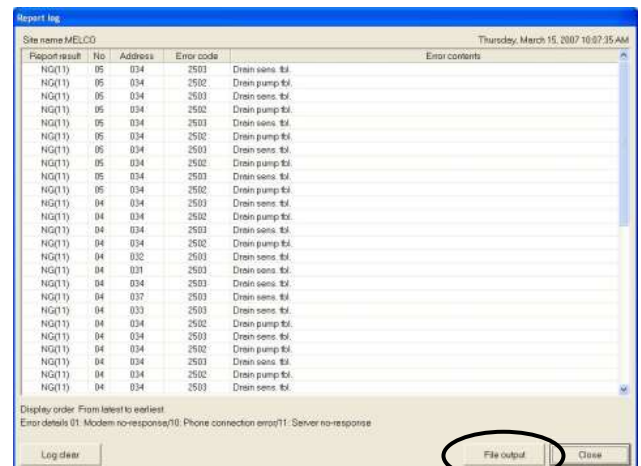

(2) Select CSV format and click **[OK]**.

Use , -- Uses a comma (,) as the delimiter in the CSV file.

Use ; -- Uses a semicolon (;) as the delimiter in the CSV file.



(3) The log is saved in CSV format and a folder display window opens. The folder name is **C:\MntToolIEA\Data**.
[See section 5.5.]

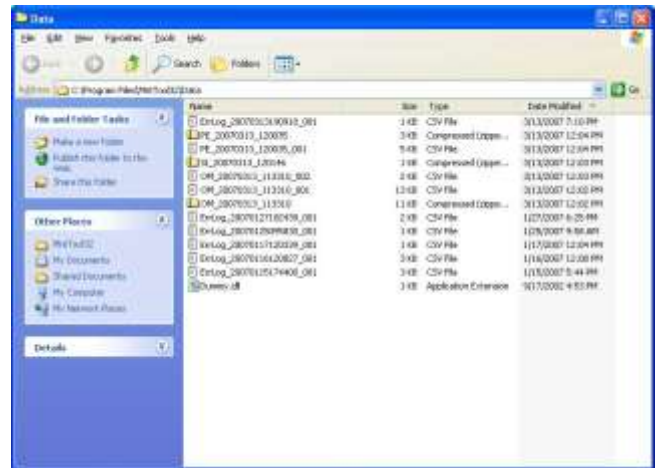

3.14.6 Changing the error notification settings

NOTE:

If you change the units targeted for error monitoring or change the MN Converter address, the MN Converter will be reset by the change. This will erase the previous error data stored on the MN Converter.

When the data is erased, notification also stops and no error report log is kept.

To retain the error data, set the **Minimum reporting period** in the Option settings to 0 minutes before sending the settings to forcibly report the error data currently stored on the MN Converter.

You can check whether there is currently error data stored on the MN Converter by the STATUS LED, which will blink at 0.5-second intervals if there is data stored.

For details, see section 3.14.10 "MN Converter LED display" (pattern 4).

- (1) Click **[Option]** in the menu bar and select **[Error notification mode]** -> **[Error notification mode setting/cancellation]** in the sub-menu.



- (2) The information set in the MN Converter is loaded and the **Error notification mode setting/cancellation screen** appears.

Units set on the MN Converter as targets for error monitoring are marked with an asterisk (*).

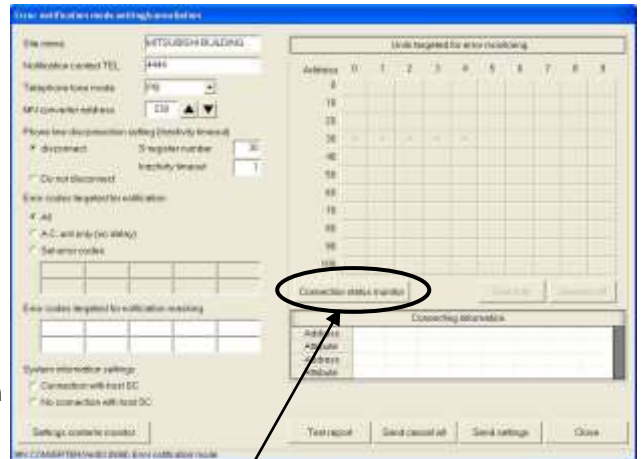

- (3) Change the desired items in the **Error notification mode setting/cancellation screen**.

To change the units targeted for error monitoring, you have to run the Connection status monitor. Click **[Connection status monitor]** to collect the connection information.

A confirmation window is displayed. Click **[Yes]**. Connection status monitor begins.



(4) Select System information settings.

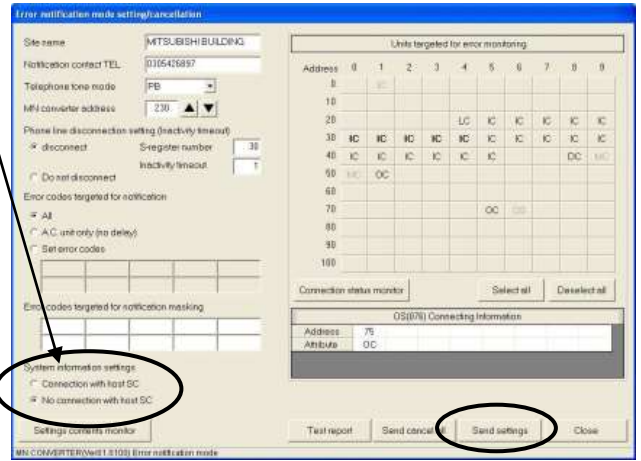

(5) Click **[Send settings]**.

A confirmation window is displayed.
Click **[Yes]**.

Setting begins.



(6) If you change the units targeted for error monitoring or change the MN Converter address, the message shown below appears.

The MN Converter is reset by the change. This erases the previous error data stored on the MN Converter. Reporting also stops and no error report log is kept.

Set the "Minimum reporting period" in the Option settings to 0 minutes before sending the settings to forcibly report the error data currently stored on the MN Converter, and click **[Yes]**.

Setting begins.

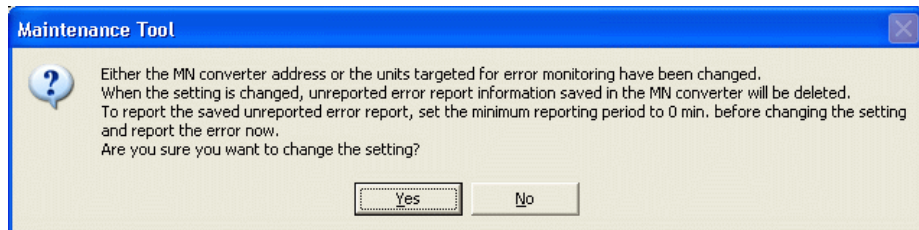

(7) The **Settings have been sent** message appears and setting is completed. Click **[OK]**.



(8) If you add the units targeted for error monitoring, the message shown below appears.
Click **[OK]**.

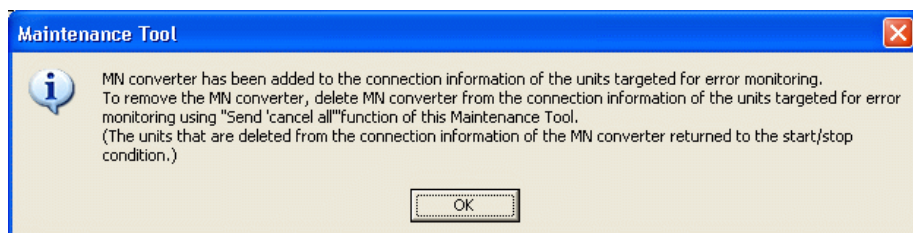

(9) Click **[Close]** to close the **Error notification mode setting/cancellation screen**.

Caution:

If you have changed the telephone number, you must run the error notification test.
[See section 3.14.4.]

NOTE:

*If you change the units to be monitored for errors when "Connection with host SC" is selected, **you must add or delete the MN Converter address in the corresponding unit connection data on the host SC.**

*To remove the MN Converter, delete MN Converter from the connection information of the units targeted for error monitoring using "Send cancel all" function of this Maintenance Tool.

*The units that are deleted from the connection information of MN Converter returned to the start/stop condition.

3.14.7 Canceling error notification mode

This procedure cancels error notification mode and returns the MN Converter to maintenance mode.

(1) In the **Error notification mode setting/cancellation screen**, click **[Send cancel all]**.

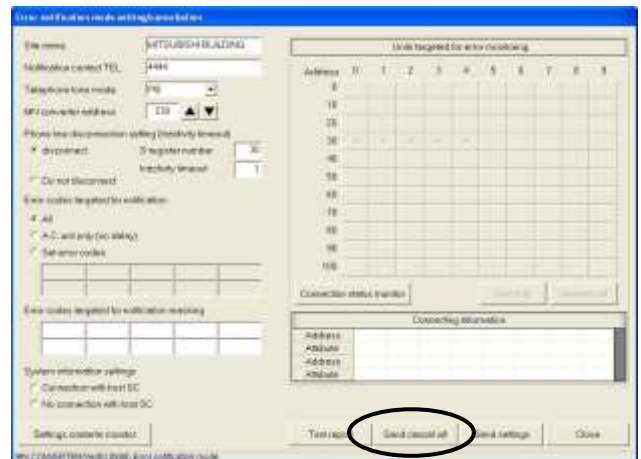

(2) A confirmation window is displayed. Click **[Yes]**.

Cancellation begins.

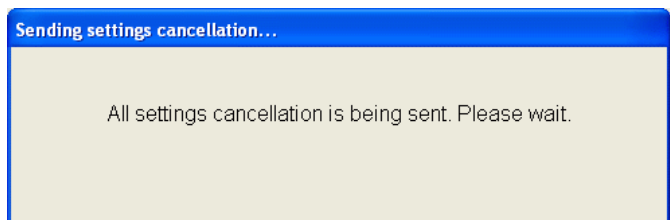
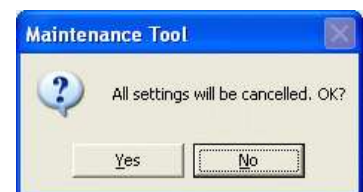

- (3) When setting is completed, the **All settings have been cancelled** message appears. Click **[OK]**.



The MN Converter switches to maintenance mode, and the message below appears. Click **[OK]**.

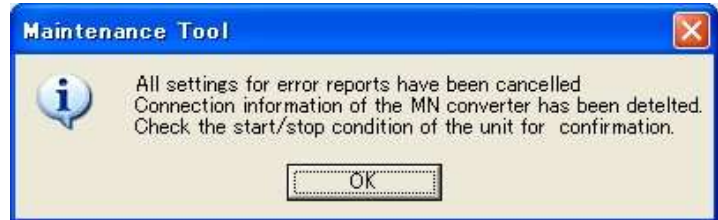

NOTE:

After cancellation, check the start/stop condition of the unit for confirmation

- (4) Click **[Close]** to close the **Error notification mode setting/cancellation screen**.

NOTE:

If you selected "Connection with host SC", you must delete the address of the MN Converter from the connection data for the corresponding unit on the host SC.

3.14.8 Option settings

Use the procedure below to specify the settings for remote error notification mode.

- (1) Click **[Option]** in the menu bar and select **[Error notification mode]** -> **[Option setting]** in the sub-menu.



- (2) The **Option setting** screen appears.

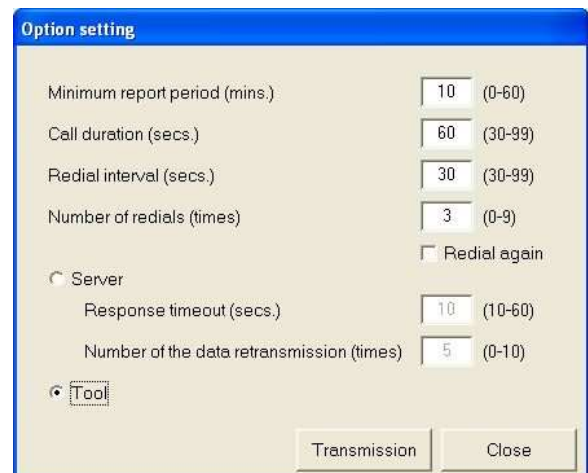

- (3) Change the settings as desired and click **[Transmission]**.

(4) The new settings are applied on the MN Converter and the window shown below appears.



NOTE:

If the MN Converter is reporting an error, the message shown below appears and the settings cannot be applied. Wait a few moments until error notification ends and then resend the settings.



The various settings are explained below.

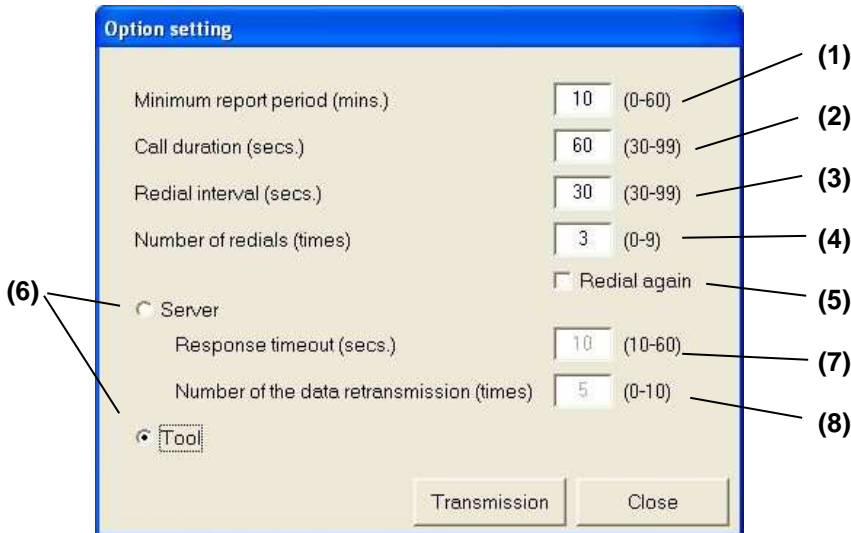

(1) Minimum reporting period (mins.) (Default = 10 min.)

Set a period between 0 and 60 minutes in 1-minute increments as the error reporting interval. Errors that occur during this period are all reported together when the end of the specified period is reached.

After the errors are reported, the next notification occurs at the end of the next reporting period. If no errors occur during this period, none are reported.

Counting of the reporting period begins when the setting is specified.

If the MN Converter is reset due to an event such as a change to the error notification setting, the counting for the minimum reporting period is also reset and errors are reported as soon as the countdown restarts.

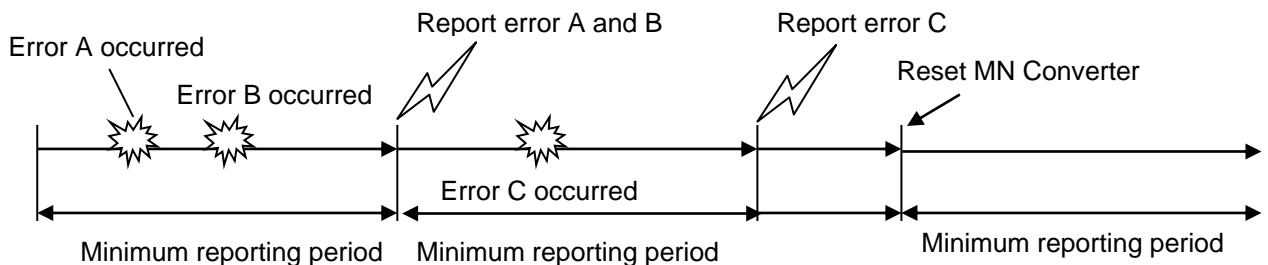

NOTE:

The maximum number of errors that the MN Converter can store during the minimum reporting period is 50. Once the limit of 50 errors is exceeded, the oldest entries in the log are deleted. When more than 50 errors occur, only the number of excess errors is reported.

(2) Call duration (secs.) (Default = 60 sec.)

Set a period between 30 and 99 seconds in 1-second increments as the time for which the MN Converter continues dialing a contact telephone number once it has started the notification process. If the contact telephone does not answer before this period expires, dialing is cancelled and notification fails. This function prevents long periods of continuous dialing.

NOTE:

Some modem models have a similar function. If this is the case and the modem's continuous dialing period is shorter than the Maintenance Tooletting, dialing stops after the period set on the modem. Refer to your modem's instruction manual for details.

- **(3) Redial interval (secs.)** (Default = 30 sec.)
 If the MN Converter dials a notification contact but the contact telephone does not answer, the converter redials the number for the number of times specified in “**(4) Number of redials**” below. In this setting, specify a period between 30 and 99 seconds in 1-second increments as the interval between redials.

- **(4) Number of redials (times)** (Default = 3 times)
 Set a number between 0 and 10 as the number of redials when the MN Converter dials a notification contact but the contact telephone does not answer.
 If you set this number to 0, the converter does not redial the number.

- **(5) Redial again** (Default = Not selected)
 If you tick this option, when the MN Converter redials a number for the number of times specified in “**(4) Number of redials**” and there is still no reply, the converter again attempts to report the same notification data after the period specified in “**(1) Minimum reporting period**” has passed. It repeats this process until notification succeeds.
 If this option is not ticked and redialing fails to establish contact, the result is stored in the error report log as a failure and that notification process ends. If this option is ticked, the result is not logged as a failure and notification is retried.

- **(6) Server/Tool** (Default = Server)
 Choose whether the software running on the remote monitoring PC connected to the notification contact is the dedicated server software or another software tool.
 - Server** ----- The MN Converter waits until it receives a “REP” character string from the remote monitoring PC in response to a notification.
 If “REP” is received, the notification result is stored in the MN Converter’s Report log as a success.
 If no response is received after a set time, the notification result is stored in the MN Converter’s Report log as a failure.
 - Tool** ----- Without waiting for a response from the remote monitoring PC, the MN Converter stores the notification result in its Report log as a success when the notification from the MN Converter is completed.

When a notification test is run, this setting is also used to identify the notification contact and determine whether notification was a success or a failure.

- **(7) Response timeout (secs.)** (Default = 10 sec.)
 When “**Server**” is selected in “**(6) Server/Tool**” above, use this setting to specify a period between 10 and 60 seconds in 1-second increments as the time for which the MN Converter waits for a “REP” response from the server.
 When “**Tool**” is selected, this setting is disabled.

- **(8) Number of the data retransmission (times)** (Default = 5 times)
 When “**Server**” is selected in “**(6) Server/Tool**” above and no “REP” response is received from the server in the time set in “**(7) Response timeout**” above, use this setting to specify a number between 0 and 10 as the number of times the MN Converter retries server notification.
 If you set this number to 0, the MN Converter does not retry notification.
 When “**Tool**” is selected, this setting is disabled.

The figure below summarizes these settings.

[If the notification contact telephone does not answer]

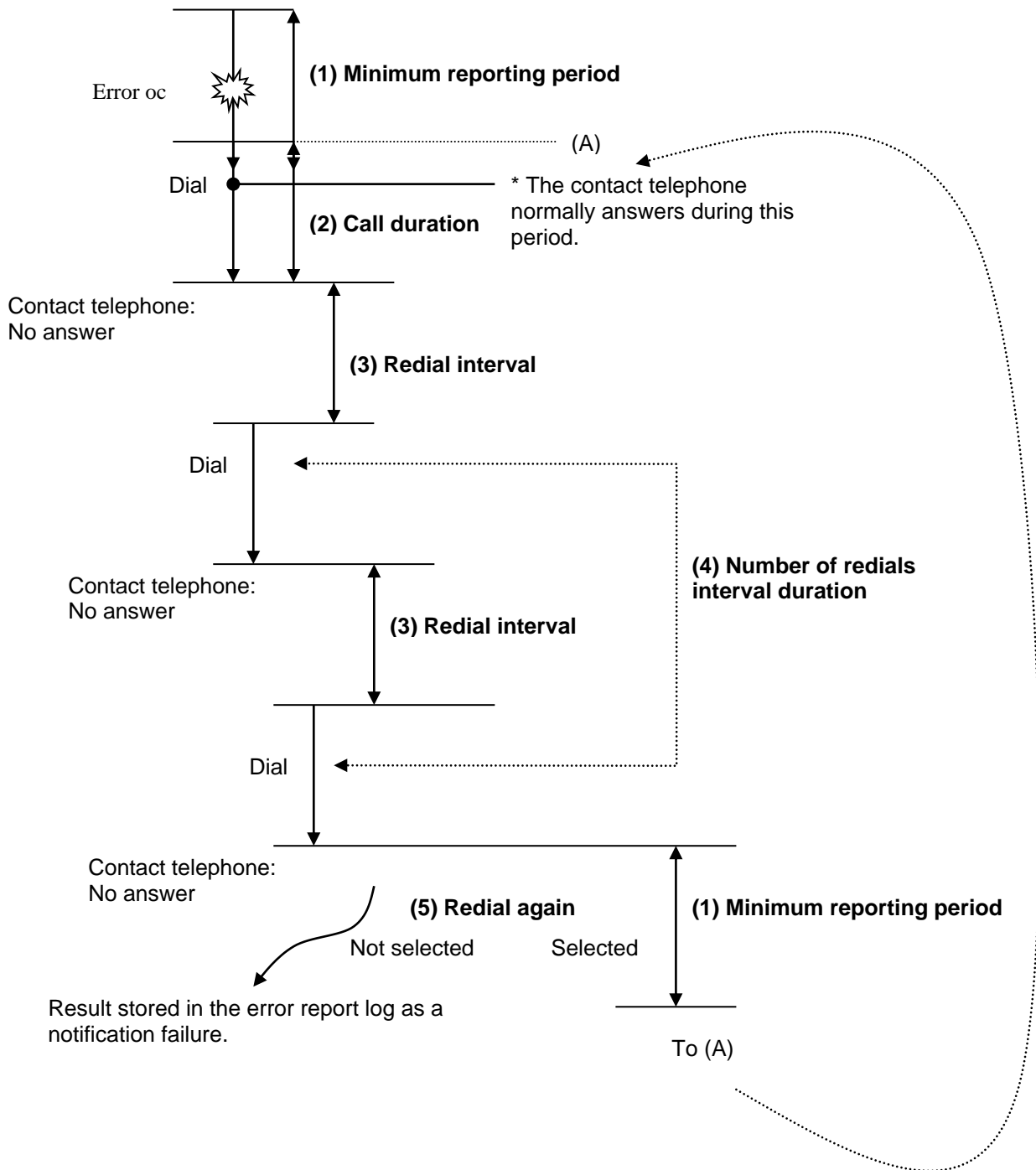

[If the notification contact telephone answers]

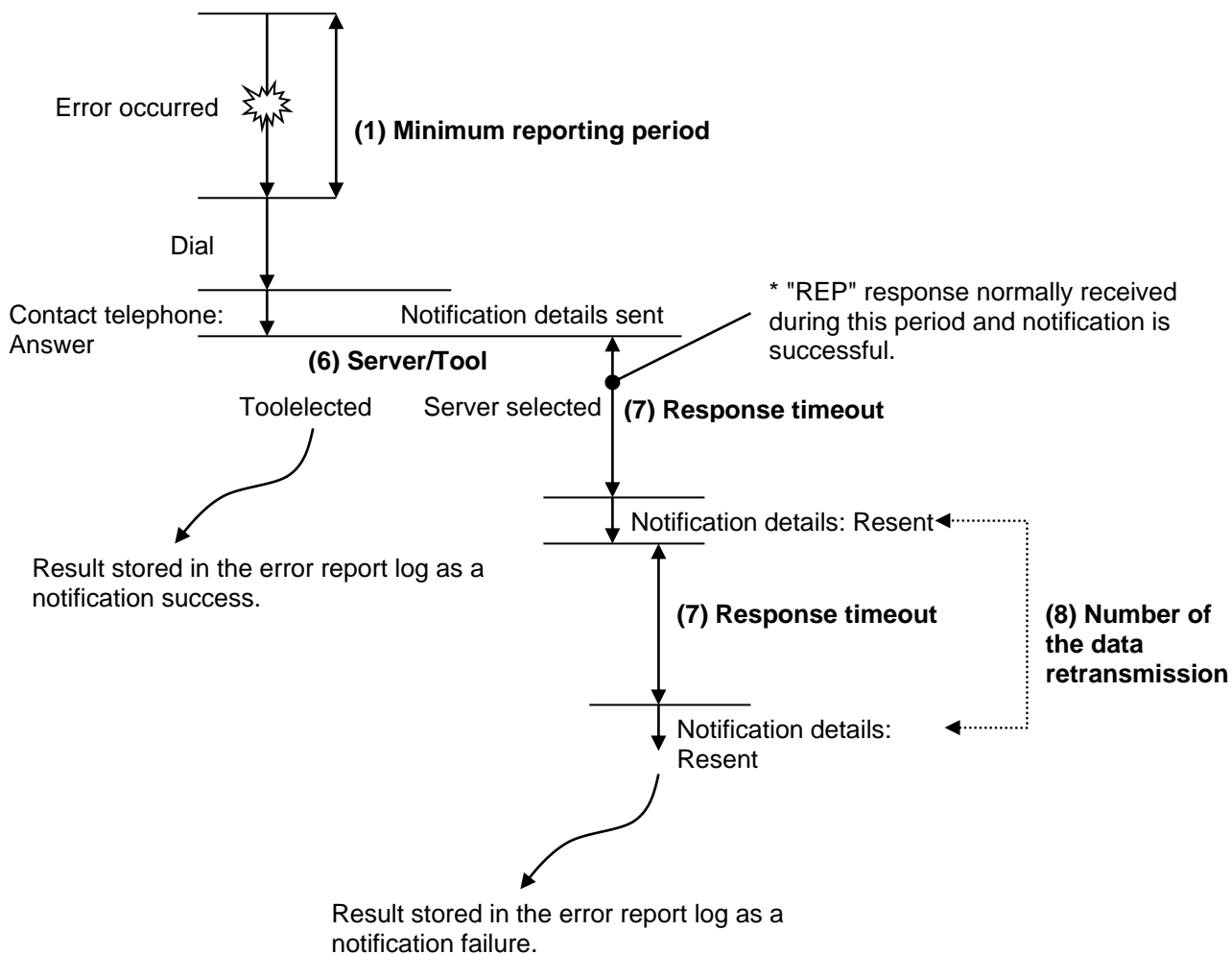

3.14.9 Error notification data format

The notification data sent from the MN Converter to the remote monitoring PC via the telephone lines is in the format shown below. The remote monitoring PC receives and processes this data in the dedicated server software or another dedicated software tool. Prior to notification, up to 50 items of error data are stored on the MN Converter. No more than 50 items of error data can be reported each time (each dialing). If there are more than 50 errors, only the number of excess errors is reported. The 50 items are divided into blocks of up to 20 items for transmission.

[Data format]

NO10	-- Notification number
MITSUBISHI ELEC BUILDING	-- Site name
0312502	-- Error data (up to 20 items)
0346607	
0352503	
* * *	
(20 or more items)	
NO11	-- Notification number
MITSUBISHI ELEC BUILDING	-- Site name
0362502	-- Error data (up to 20 items)
0346608	
0352504	
* * *	
(40 or more items)	
NO12	-- Notification number
MITSUBISHI ELEC BUILDING	-- Site name
0362502	-- Error data (up to 10 items)
0346608	
0352504	
* * *	
OVER12	-- Number of items in excess of 50 (if there are more than 50 items)

- Notification number

NO + notification number

The number increments by 1 for each item up to 50 items. When 50 is reached, numbering restarts at 1. If there are more than 20 items of error data, the notification is divided and the notification number increments by 1 for each item. The notification number displayed by the Maintenance Tool matches the error report log number on the MN Converter. When the log is cleared in the Maintenance Tool error report log screen, the numbering restarts from 1. The notification number for a test notification is 0.

- Site name

Site name

The site name specified in the **Error notification mode setting/cancellation screen**.

- Error data

Address of unit on which the error occurred (3 digits) + error code (4 digits)

For a test notification, the unit where the error occurred is "MN Converter's address" and the error code (1 only) is "0000".

- Number of errors in excess of 50

OVER + the number of errors in excess of 50

3.14.10 MN Converter LED display

The MN Converter (CMS-MNG-E) has a STATUS LED (yellow) that displays the converter status.

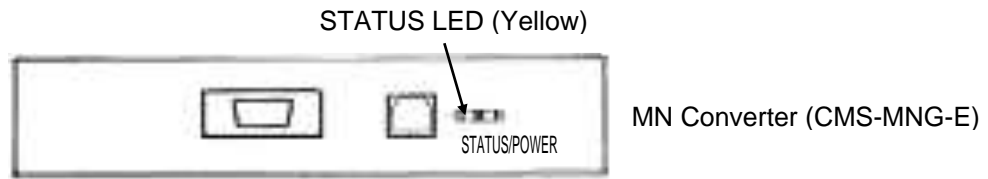

The STATUS LED blinking patterns are shown below.

[Maintenance mode]

- Lit: Ready for operation. (normal)
- Unlit: Not ready for operation. (error)

[Remote error notification mode]

- Lit: Ready for operation. (normal)
- Unlit: Not ready for operation. (error)
- Blink: When the remote error notification activates, the LED light blinks according to the following blink patterns:

■ ..Lit (Unit: second)

Pattern	Explanation	Priority*	Blinking pattern	Operation status
1	Slow blink	High	■	Modem error
2	Long blink	↑ Low	0.5 ■ 2.0 ■ 0.5	Remote error notification failed
3	Double blink		0.2-0.1-0.2-0.5 0.5 ■ ■ ■	Redialing
4	Blinking		2.0 ■ 0.5 ■ 2.0	Air-conditioner error

Pattern

1-----Modem error

0.5

Unable to communicate with the modem. The MN Converter is not connected to the modem or the modem is not turned on. Check the connection to the modem and that the modem is turned on.

(*When all of the operation statuses occur at a time, the status with the highest priority is displayed.)

2-----Remote error notification failed

A failed notification result is saved in the Report log stored on the MN Converter. [See section 3.14.5.]

If the LED is displaying this pattern, check the Report log in the Maintenance Tool and eliminate the cause of the failure.

When the Report log is displayed, the software recognizes that the log has been “checked by a person” and resets the display pattern.

When it reaches the limit of 50 items stored in the Report log, and the oldest entries that exceed the 50 limits are deleted. The display is reset when there are no failure results in the Report log.

3-----Redialing

The LED blinks in this pattern while the MN Converter is redialing after there is no answer from a notification contact telephone.

4-----Air-conditioner error

The LED blinks in this pattern when an error requiring notification has occurred in one of the units being monitored for errors and the MN Converter is storing the error data. If an error occurs in a unit that is not being monitored for errors, or if the error code is masked or does not require notification, the LED does not blink. This display is reset when error notification is carried out.

3.15 Setting and Monitoring DIDO/AI/PI Controllers

The “Setting and Monitoring DIDO/AI/PI Controllers” has been located starting from Ver4.20.

*** Items Performed Here**

- Settings and monitoring DIDO Controller (PAC-YG66DCA), AI Controller (PAC-YG63MCA), and PI Controller (PAC-YG60MCA) can be made. (PI Controllers can be used only for monitoring.)
- DIDO Controllers and AI Controllers have an interlock control function.
 DIDO Controllers can also change the operation status of M-NET devices (such as indoor units, DIDO Controllers) by sending operation commands. DIDO Controllers can output contacts on DIDO Controllers themselves depending on the change in input contact status.
 AI Controllers can change the operation status of M-NET devices (such as indoor units, DIDO Controllers) by sending operation commands depending on the change in measurement values.
“Interlock operation conditions” for the “interlock control function” can be set on Maintenance Tool.

NOTE:
 Before using the interlock control function, plan carefully how the air-conditioners will be used. If the interlock control function is used without thorough consideration, unexpected operation may result.

3.15.1 Setting and Monitoring DIDO Controllers (66DC)

DIDO Controller(PAC-YG66DCA) can be used in combination with a system controller (Centralized Controller or TG-2000A) to operate/stop general-purpose equipment, as well as to monitor the operating status and error status.

Furthermore, DIDO Controller is equipped with two sets (channels 1 and 2) of standard terminals and four sets of expansion connectors as the input/output terminals.

(a) ON/OFF, (ON) output
 (b) (OFF) output
 (c) ON/OFF input
 (d) Error/Normal input
 Standard: Terminal block (for 2 units)
 Expansion: Connectors (for 4 units)
 Total: 6 units

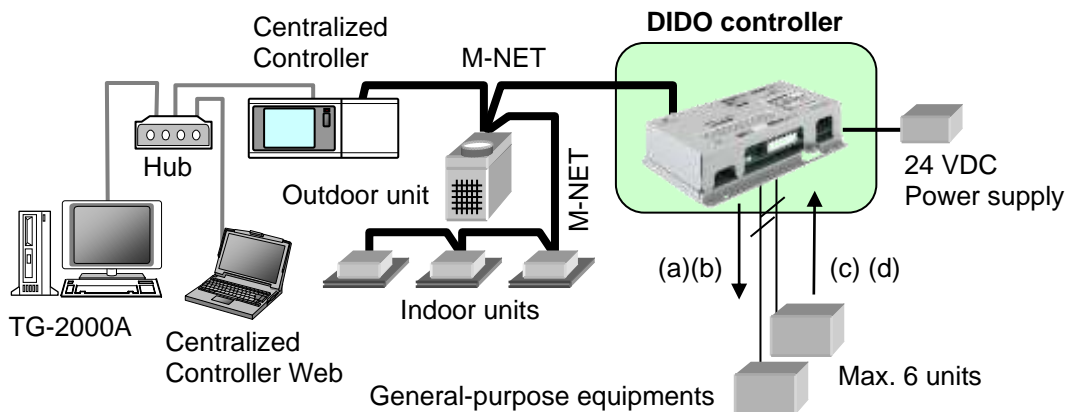

The function allotment of DIDO Controller, Centralized Controller Web Browser, TG-2000A and Maintenance Tool is as follows.

[Note]S:Setting possibility, M:Monitoring only, -:None

Function name	DIDO Controller	Centralized Controller Web	TG-2000A	Maintenance Tool
Address setting	S*1	-	-	M
Output method (Level/pulse) setting	S*1	-	-	M
Error input logic (a contact/b contact) setting	S*1	-	-	M
Group registration	-	S	S	-
Operation and monitoring	-	S	S	M (Compulsion operation is possible.)
Time setting	-	S	S	M (Operation is possible)*2

*1 It is set with Dip switch of DIDO Controller.

*2 When Centralized Controller or TG-2000A is connected, the time setting must be made on Centralized Controller Web Browser or TG-2000A.

The following settings and monitoring can be made on DIDO Controllers (PAC-YG66DCA).

Set the current time before using the DIDO Controller.

When Centralized Controller or TG-2000A is connected, the time setting must be made on Centralized Controller Web or TG-2000A.

When neither of them is connected, refer to section [3.15.1.1 Time setting on DIDO Controllers].

- (a) Operation
 - *Contact output
 - *Operation time reset
- (b) Monitoring
 - *Input/output status
 - *Operation time (contact ON/OFF hours)
 - *Dip switch settings

3.15.1.1 Time setting on DIDO Controllers

NOTE:

When Centralized Controller or TG-2000A is connected, the time setting must be made on Centralized Controller Web or TG-2000A.

- (1) Click **[Option]** in the menu bar and select **[DIDO/AI/PI] -> [DIDO setting]** in the sub-menu.
- (2) Click **[DC]** of the unit (DIDO Controller) to be set or monitored on the **Main screen**.
- (3) **DIDO controller (66DC) input/output status monitoring screen** will appear.
- (4) Click **[Date/Time setting]** in the **DIDO controller (66DC) input/output status monitoring screen**.

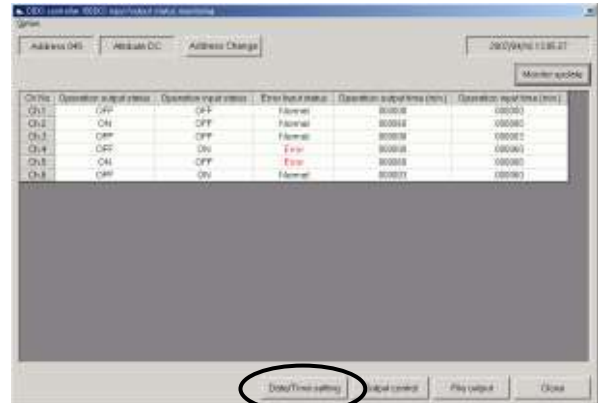

- (5) The current time is monitored, and **Date/Time setting screen** will appear.
- (6) Set the current date and time.
- (7) Click **[Send settings]**.
- (8) The message **"Are you sure you want to send the Date/Time setting?"** will appear. Click **[Yes]**.
- (9) Time is set to DIDO Controller, and the message **"Settings have been sent."** Will appear. Click **[OK]**.
- (10) Click **[Close]** to return to the **DIDO controller (66DC) input/output status monitoring screen**.

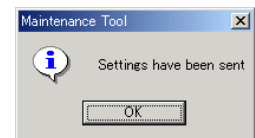

3.15.1.2 Monitoring input/output status on DIDO Controllers (66DC)

(1) Click **[Option]** in the menu bar and select **[DIDO/AI/PI] -> [DIDO setting]** in the sub-menu.



(2) Click **[DC]** of the unit (DIDO Controller) to be set or monitored on the **Main** screen.

(3) The input/output status is monitored, and **DIDO controller (66DC) input/output status monitoring screen** will appear.

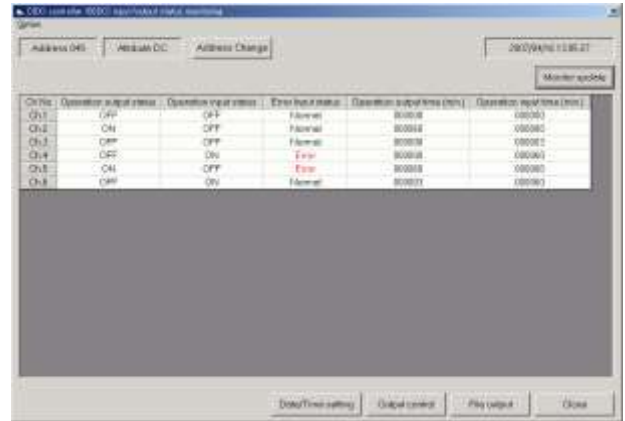

[Operation output status]

[Operation input status]

The ON/OFF status for each contact is monitored and displayed.

[Error input status]

The error input status for each contact is monitored and displayed.

[Operation output time(min.)]

[Operation input time(min.)]

The integrated operation time for operation ON/OFF time is monitored and displayed.

(4) Click **[Monitor update]** to update the monitoring status.

(5) Click **[File output]** to save the monitored information as a CSV file.

1) Click **[File output]**.

2) The message “**Please select symbols for use as delimiters.**” Will appear. Click **[Use ,]** or **[Use ;]**.

3) **[File]** is output and saved.

The output destination folder path will be displayed.

The folder name is

C:\MntTool\EA\Data.

[See section 5.6.]



3.15.1.3 Output control

- (1) Click **[Output control]** in the **DIDO controller (66DC) input/output status monitoring screen**.

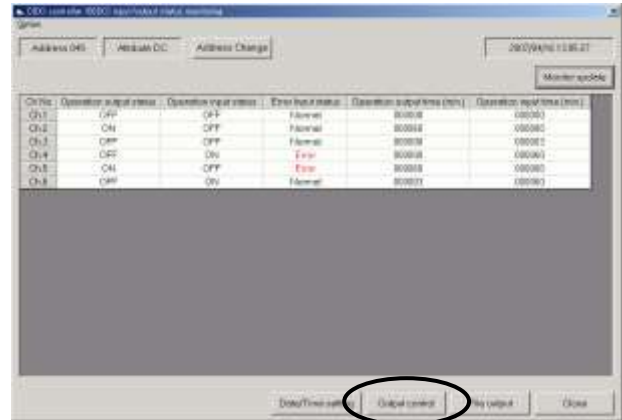

- (2) The current output status is monitored, and **Output control screen** will appear.

* **The pressed (sunken) button shows the current status.**

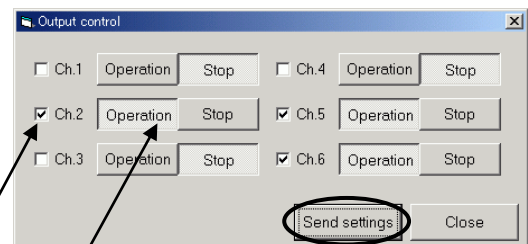

- (3) Check the checkbox of the channel to be output.

- (4) Click **[Operation]** or **[Stop]**.

- (5) Click **[Send settings]**.

- (6) The message **"Settings will be sent. OK?"** will appear, click **[Yes]**.
The setting will be applied to the unit.



- (7) The message **"Settings have been sent."** Will appear, click **[OK]**.

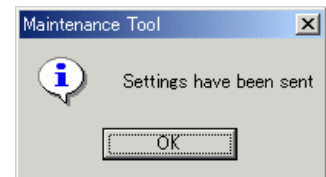

- (8) Click **[Close]** to return to the **DIDO controller (66DC) input/output status monitoring screen**.

3.15.1.4 Monitoring Dip switch setting of DIDO Controllers

- (1) Click [Option] in the **DIDO controller (66DC) input/output status monitoring screen** and select [DIP switch setting monitoring] in the sub-menu.

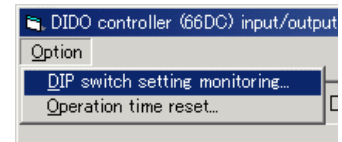

- (2) The DIP switch setting is monitored, and **DIP switch setting monitoring screen** will appear.

* **The pressed (sunken) button shows the current status.**



- (3) Click [File output] to save the monitored information as a CSV file. Refer to section [3.14.1.2 Monitoring input/output status on DIDO Controllers (66DC) (5)]. The folder name is **C:¥MntToolEA¥Data**. [See section 5.6.]
- (4) Click [Close] to return to the **DIDO controller (66DC) input/output status monitoring screen**.

3.15.1.5 Operation time reset

- (1) Click [Option] in the **DIDO controller (66DC) input/output status monitoring screen** and select [Operation time reset] in the sub-menu.

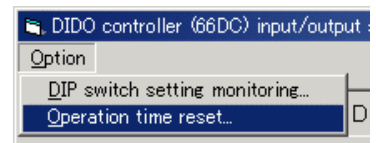

- (2) **Operation time reset screen** will appear.

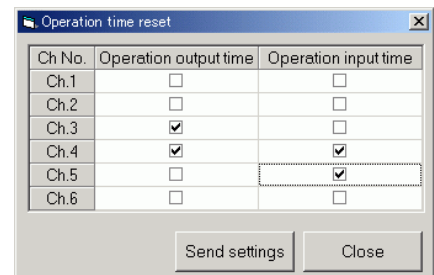

- (3) Check the checkbox of to reset the operation time of the selected channel.
- (4) Click [Send settings].
- (5) The message "Settings will be sent. OK?" will appear, click [Yes]. The setting will be applied to the unit.
- (6) The message "Settings have been sent." will appear, click [OK].
- (7) Click [Close] to return to the **DIDO controller (66DC) input/output status monitoring screen**.

3.15.2 Setting and Monitoring AI Controllers (63MC)

AI Controller (PAC-YG63MCA) is capable of measuring the temperature and humidity. Trend displays of measurement data can be shown on the Centralized Controller Web Browser and TG-2000A. Furthermore, an alarm can be output if measurement data exceeds a preset upper or lower limit.

- (1) Channel 1 temperature or humidity sensor input
 - (2) Channel 2 temperature or humidity sensor input
 - (3) Channel 1 upper/lower limit alarm output
 - (4) Channel 2 upper/lower limit alarm output

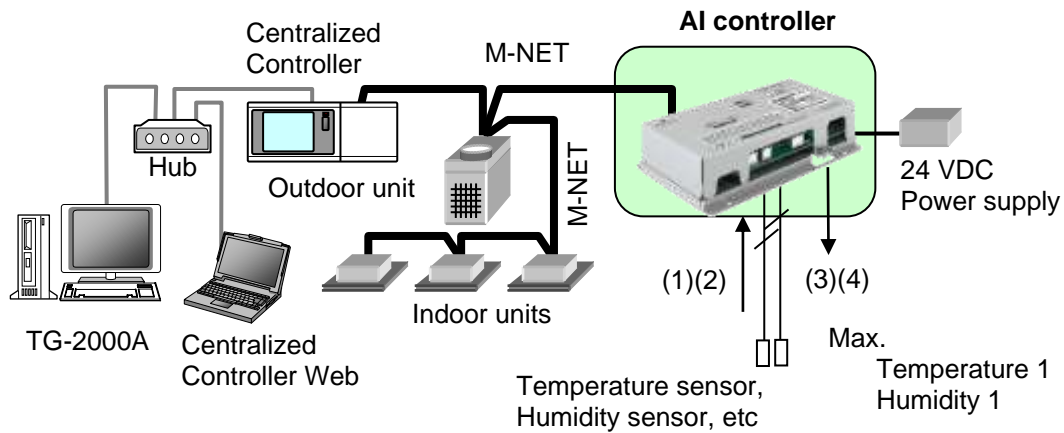

The function allotment of AI Controller, Centralized Controller Web Browser, TG-2000A and Maintenance Tool is as follows.

[Note] S:Setting possibility, M:Monitoring only, -:None

Function name	AI Controller	Centralized Controller Web	TG-2000A	Maintenance Tool
Address setting	S*1	-	-	M
Setting of the input to use	S*1	-	-	M
Setting of the analog input type	S*1	-	-	M
Range and category setting of sensor	-	S	S	M (Operation is possible)*2
Setting of upper/lower limit alarm interlock output use	S*1	-	-	M
Range setting of Upper/Lower limit alarm	-	S	S	M (Operation is possible)*2
Monitoring and trend displays of measurement data	-	S	S	M (Monitoring only)
Time setting	-	S	S	M (Operation is possible)*2

*1 It is set with Dip switch of DIDO Controller.

*2 When Centralized Controller or TG-2000A is connected, the time setting must be made on Centralized Controller Web Browser or TG-2000A.

The following settings and monitoring can be made on AI Controllers (PAC-YG63MCA).

When Centralized Controller or TG-2000A is connected, the setting must be made on Centralized Controller Web Browser or TG-2000A.

- (a) Settings
 - *Current time
 - *Measurement category (temperature, humidity)
 - *Measurement range (upper limit, lower limit, correction value)
 - *Out-of limit alarm value (alarm threshold, alarm-off threshold)
- (b) Monitoring
 - *Current measurement value
 - *Current out-of-limit alarm status
 - *Correction value for Pt100 detection
 - *Dip switch setting
 - *Measurement value history
 - *History of out-of-limit alarm/alarm-off
 - *Change history of measurement category (temperature or humidity)

NOTE:
The temperature is displayed in the unit (°C or °F) that has been selected at Maintenance Tool startup

3.15.2.1 Monitoring measurement value on AI Controllers (63MC)

- (1) Click **[Option]** in the menu bar and select **[DIDO/AI/PI] -> [AI/PI setting]** in the sub-menu.
- (2) Click **MC** of the unit (AI Controller) to be set or monitored on the **Main screen**.
- (3) The current measurement value is monitored, and **AI controller (63MC) measurement value monitoring screen** will appear.

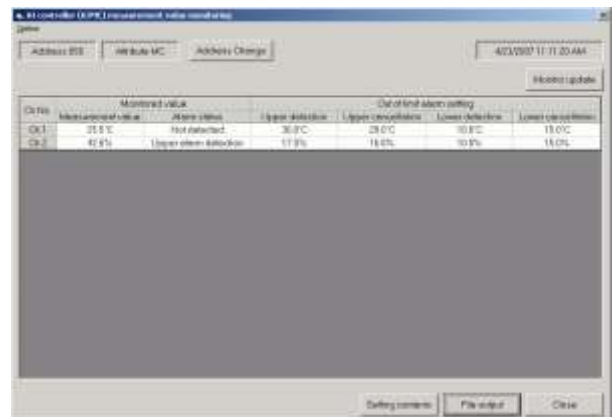
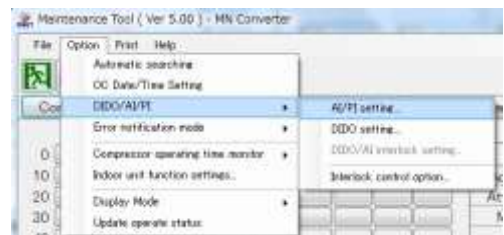

[Measurement value]

The current measurement value of each channel is shown.

[Alarm status]

The current out-of-limit alarm status is shown.

[Upper detection] [Upper cancellation]

[Lower detection] [Lower cancellation]

The preset alarm detection value and alarm cancellation value are shown.

- (4) Click **[Monitor update]** to update the monitoring status.
- (5) Click **[File output]** to save the monitored information as a CSV file. Refer to section [3.15.1.2 Monitoring input/output status on DIDO Controllers (66DC) (5)]. The folder name is **C:\MntToolEA\Data**. [See section 5.7.]

3.15.2.2 Setting for AI Controllers (63MC)

NOTE:

When Centralized Controller or TG-2000A is connected, the setting must be made on Centralized Controller Web Browser or TG-2000A.
 When the settings are made on Maintenance Tool, the setting change is not applied to Centralized Controller or TG-2000A.

- (1) Click **[Setting contents]** in the AI controller (63MC) measurement value monitoring screen.



- (2) The setting details are monitored, and, **AI controller (63MC) setting screen** will appear.

[Category]

The measurement category (temperature or humidity) is shown.

[Upper limit value][Lower limit value]

The upper/lower limits of the measurement range are shown.

<Settable range>

In case of temperature:-100.0°C to 100.0°C
 (-148.0°F to 212.0°F)

In case of humidity:0.0% to 100.0%

Note that the range must be fixed between
 -30.0°C and 60.0°C (-22.0°F and 140.0°F)
 when the temperature sensor for Pt100 detection
 (Ch1 only) is used.

[Correction value]

The correction value is shown.

< Settable range >

In case of temperature:-10.0°C to 10.0°C (-18.0°F to 18.0°F)

In case of humidity:-10.0% to 10.0%

[Upper limit alarm detection] [Upper limit alarm cancellation]

[Lower limit alarm cancellation] [Lower limit alarm detection]

The alarm detection value and the alarm cancellation value are shown.

[Time setting]

The current date and time is shown.

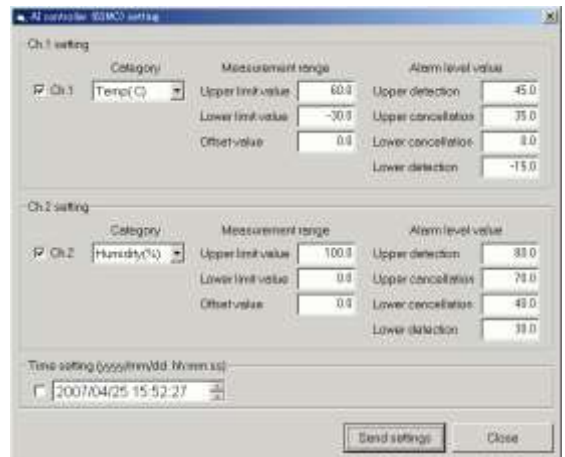

- (3) Check the checkbox of the channel to be output and the check box of **[Time setting]** (when time setting is needed).

- (4) Change the settings.

- (5) Click **[Send settings]**.
- (6) The message **"Settings will be sent. OK?"** will appear, click **[Yes]**.
The setting will be applied to the unit.
- (7) The message **"Settings have been sent."** Will appear, click **[OK]**.
- (8) Click **[Close]** to return to the **AI controller (63MC) measurement value monitoring screen**.

NOTE:

When you use Fahrenheit for the unit, there might be differences of the plus or minus 0.1 °F in the set value and the value monitored after it sets it.

3.15.2.3 Monitoring Dip switch setting of AI Controllers

- (1) Click **[Option]** in the **AI controller (63MC) measurement value monitoring screen** and select **[DIP switch setting monitoring]** in the sub-menu.

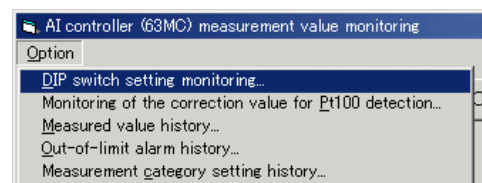

- (2) The DIP switch setting is monitored, and **DIP switch setting monitoring screen** will appear.



* **The pressed (sunken) button shows the current status.**

- (3) Click **[File output]** to save the monitored information as a CSV file.
Refer to section [3.15.1.2 Monitoring input/output status on DIDO Controllers (66DC) (5)].
The folder name is **C:\MntToolEA\Data**.
[See section 5.7.]
- (4) Click **[Close]** to return to the **AI controller (63MC) measurement value monitoring screen**.

3.15.2.4 Monitoring of the correction value for Pt100 detection

- (1) Click **[Option]** in the **AI controller (63MC) measurement value monitoring screen**, and select **[Monitoring of the correction value for Pt100 detection]** in the sub-menu.

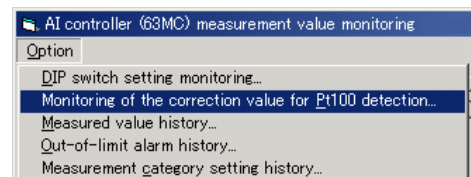

- (2) The correction value for Pt100 detection is monitored, and **Monitoring of the correction value for Pt100 detection screen** will appear.

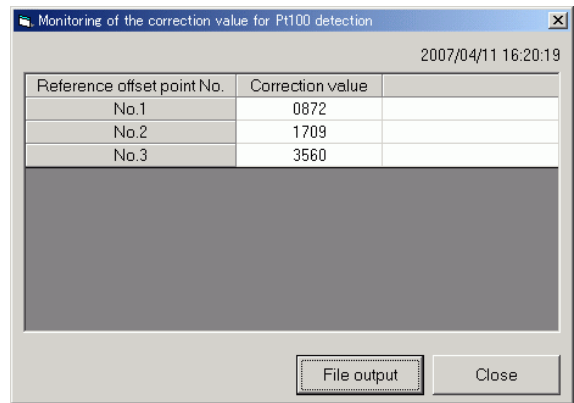

[Correction value]

The correction value for each Reference correction point No. is shown.

- (3) Click **[File output]** to save the monitored information as a CSV file.
 Refer to section [3.15.1.2 Monitoring input/output status on DIDO Controllers (66DC) (5)].
 The folder name is **C:\MntToolEA\Data**.
 [See section 5.7.]
- (4) Click **[Close]** to return to the **AI controller (63MC) measurement value monitoring screen**.

3.15.2.5 Measured value history

The measurement values in the past are displayed. Up to 120 of the latest data can be displayed.

- (1) Click **[Option]** in the **AI controller (63MC) measurement value monitoring screen** and select **[Measured value history]** in the sub-menu.

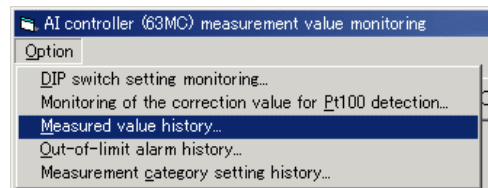

- (2) The measured value history is monitored, and **Measured value history screen** will appear.

[Date/Time]

The date and time when the measurement is made is shown.

[Ch.1 Measurement value]

[Ch.2 Measurement value]

The measurement value of each channel is shown.

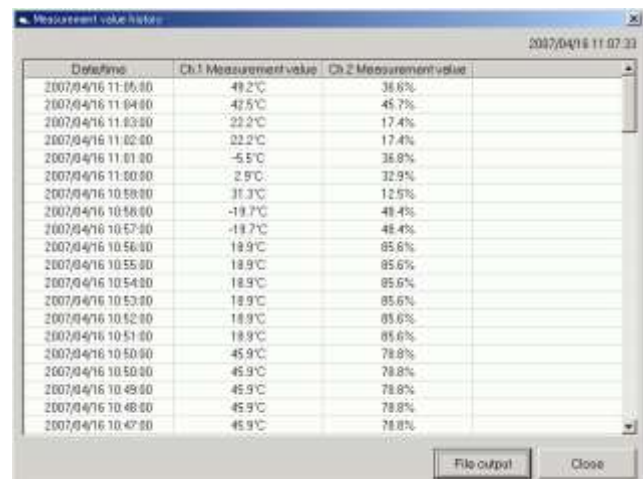

- (3) Click **[File output]** to save the monitored information as a CSV file.
 Refer to section [3.15.1.2 Monitoring input/output status on DIDO Controllers (66DC) (5)].
 The folder name is **C:\MntToolEA\Data**.
 [See section 5.7.]
- (4) Click **[Close]** to return to the **AI controller (63MC) measurement value monitoring screen**.

3.15.2.6 Out-of-limit alarm history

The history of out-of-limit alarm/alarm-off is displayed. Up to 100 of the latest data can be displayed.

- (1) Click **[Option]** in the **AI controller (63MC) measurement value monitoring screen**, and select **[Out-of-limit alarm history]** in the sub-menu.

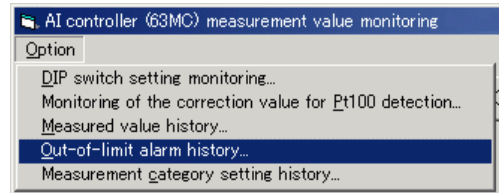

- (2) The out-of-limit alarm history is monitored, and **Out-of-limit alarm history** screen will appear.

[Date/Time]

The date and time when the alarm is activated/deactivated is shown.

[Interlock signal contact output]

The output status of interlock signal contact is shown.

[Alarm status]

The alarm status (out-of-limit alarm ON or OFF) is shown.

[Measurement value]

The measurement value when an alarm is detection/cancellation is shown.

Date/Time	Interlock signal contact output	Alarm status	Measurement value
4/23/2007 09:04:28	No output	Upper alarm cancellation	26.5°C
4/23/2007 09:05:14	Signal being output	Upper alarm detection	21.7°C
4/19/2007 08:16:25	No output	Upper alarm cancellation	28.1°C
4/19/2007 07:24:54	Signal being output	Upper alarm detection	28.1°C
4/19/2007 09:21:30	No output	Lower alarm cancellation	21.1°C
4/19/2007 09:30:16	Signal being output	Lower alarm detection	19.9°C
4/19/2007 10:07:29	No output	Lower alarm cancellation	21.1°C
4/19/2007 10:42:11	Signal being output	Lower alarm detection	19.9°C
4/19/2007 13:11:16	No output	Upper alarm cancellation	24.9°C
4/19/2007 11:00:25	Signal being output	Upper alarm detection	26.7°C
4/19/2007 09:48:51	No output	Upper alarm cancellation	26.4°C
4/19/2007 09:48:28	Signal being output	Upper alarm detection	26.4°C
4/19/2007 09:44:58	No output	Upper alarm cancellation	26.4°C
4/19/2007 08:10:27	Signal being output	Upper alarm detection	26.1°C
4/19/2007 09:47:33	No output	Lower alarm cancellation	21.1°C
4/17/2007 09:12:58	Signal being output	Lower alarm detection	19.9°C
4/15/2007 10:30:16	No output	Lower alarm cancellation	21.1°C
4/15/2007 09:34:36	Signal being output	Lower alarm detection	19.9°C
4/15/2007 09:30:58	No output	Lower alarm cancellation	19.9°C
4/16/2007 11:35:06	Signal being output	Lower alarm detection	19.9°C

- (3) Select the channel **[Ch1]** or **[Ch2]** to be monitored using the pulldown.

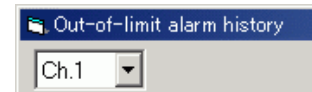

- (4) Click **[History clear]** to clear the history of out-of-limit alarm/alarm-off.

- 1) Click **[History clear]**.
- 2) The message **"Do you want to clear the history?"** will appear, and click **[Yes]**.



- 3) The message **"The history was cleared."** Will appear., and click **[OK]**.

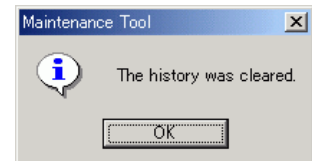

- (5) Click **[File output]** to save the monitored information as a CSV file.

Refer to section [3.15.1.2 Monitoring input/output status on DIDO Controllers (66DC) (5)].

The folder name is

C:\MntTool\EA\Data.

[See section 5.7.]

- (6) Click **[Close]** to return to the **AI controller (63MC) measurement value monitoring screen**.

3.15.2.7 Measurement category setting history

The change history of measurement category (temperature or humidity) is displayed. Up to 10 of the latest data can be displayed.

- (1) Click **[Option]** in the **AI controller (63MC) measurement value monitoring screen** and select **[Measurement category setting history]** in the sub-menu.

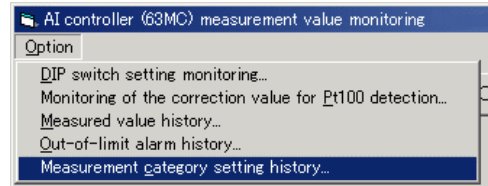

- (2) The measurement category setting history is monitored, and **Measurement category setting history screen** will appear.

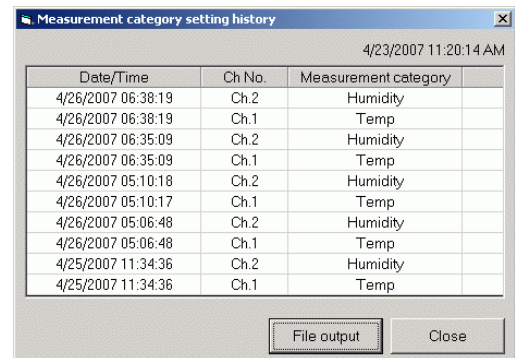
A screenshot of a software window titled "Measurement category setting history". The window shows a table with the following data:

Date/Time	Ch No.	Measurement category
4/26/2007 06:38:19	Ch.2	Humidity
4/26/2007 06:38:19	Ch.1	Temp
4/26/2007 06:35:09	Ch.2	Humidity
4/26/2007 06:35:09	Ch.1	Temp
4/26/2007 05:10:18	Ch.2	Humidity
4/26/2007 05:10:17	Ch.1	Temp
4/26/2007 05:06:48	Ch.2	Humidity
4/26/2007 05:06:48	Ch.1	Temp
4/25/2007 11:34:36	Ch.2	Humidity
4/25/2007 11:34:36	Ch.1	Temp

The window also shows a timestamp "4/23/2007 11:20:14 AM" and two buttons: "File output" and "Close".

[Date/Time]

The date and time when the measurement category is changed is shown.

[Ch No.]

The channel on which the measurement category is changed is shown.

[Measurement Category]

The measurement category after the change has been made is shown.

- (3) Click **[File output]** to save the monitored information as a CSV file.
Refer to section [3.15.1.2 Monitoring input/output status on DIDO Controllers (66DC) (5)].
The folder name is **C:\MntToolEA\Data**.
[See section 5.7.]
- (4) Click **[Close]** to return to the **AI controller (63MC) measurement value monitoring screen**.

3.15.3 Monitoring PI Controllers (60MC)

PI Controller (PAC-YG60MCA) counts pulses from a power meter, gas meter, water meter, and calorimeter. The combined use of the Centralized Controller and TG-2000A allows for calculating the charges for each unit and performing peak-cut operation (demand control).

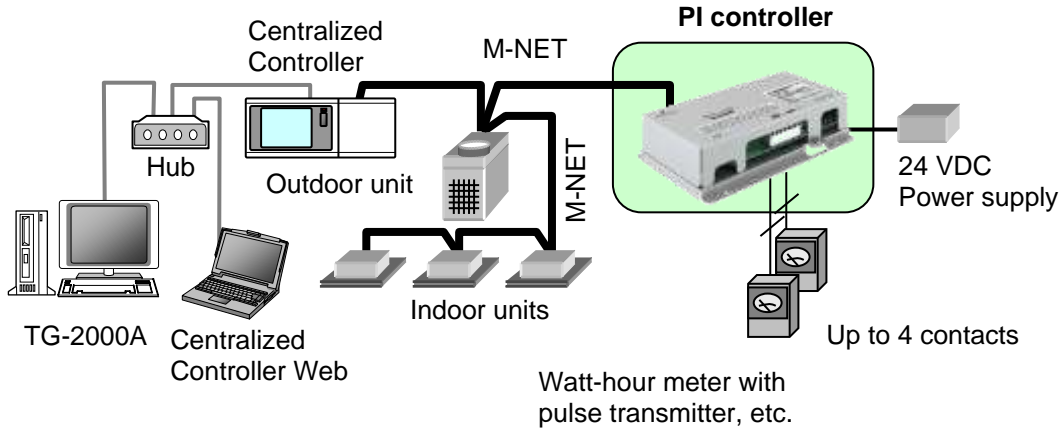

The function allotment of PI Controller, Centralized Controller Web Browser, TG-2000A and Maintenance Tool is as follows.

[Note] S:Setting possibility, M:Monitoring only, -:None

Function name	PI Controller	Centralized Controller Web	TG-2000A	Maintenance Tool
Address setting	S*1	-	-	M
Use of input contact setting	S*1	-	-	M
Pulse weight value setting	S*1	S*2	S*2	M
Charge time zone setting	-	-	S	M
Time setting	-	S	S	M

*1 It is set with Dip switch of DIDO Controller.

*2 When Centralized Controller or TG-2000A is connected, the time setting must be made on Centralized Controller Web Browser or TG-2000A.

The following monitors of PI Controllers (PAC-YG60MCA) can be done.

NOTE:

The setting must be made on Centralized Controller Web Browser or TG-2000A.

- *Current measurement value
- *Measurement data history (cumulative value) (for the last 7 days)
- *Measurement data history (settlement date) (up to 3 data of the last 3 settlement days in each month)
- *Power failure/restoration history
- *Pulse unit (weight) change history
- *Current time
- *Pulse unit (weight) setting
- *Measurement unit setting
- *Measurement data recording intervals
- *Charge time zone setting
- *Thermal storage device connection setting
- *Settlement day setting
- *Dip switch setting

3.15.3.1 PI Controller (60MC) measurement value Monitor (current value)

(1) Click **[Option]** in the menu bar and select **[DIDO/AI/PI] -> [AI/PI setting]** in the sub-menu.



(2) Click **MC** of the unit (PI Controller) to be monitored on the **Main screen**.

(3) The current measurement value is monitored, and **PI controller (60MC) measurement value monitoring screen** will appear.

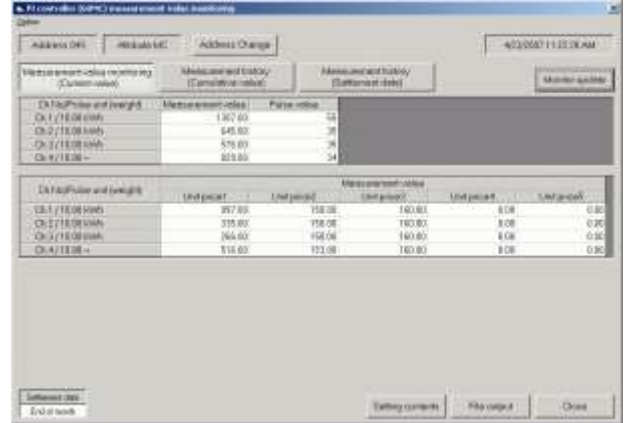

[Ch No/Pulse unit (weight)]

The current pulse unit (weight) of each channel is shown.

[Measurement value]

The current measurement value is shown.

[Pulse value]

The current pulse value is shown.

[Unit price 1 to 5]

The current measurement value per unit price is shown.

[Settlement date]

The settlement date is shown.

(4) Click **[Monitor update]** to update the measurement values.

(5) Click **[File output]** to save the monitored information as a CSV file.

Refer to section [3.15.1.2 Monitoring input/output status on DIDO Controllers (66DC) (5)].

The folder name is

C:\MntTool\EA\Data.

[See section 5.8.]

3.15.3.2 PI Controller (60MC) measurement value Monitor (cumulative value)

(1) Click **[Measurement data history (cumulative value)]** in the **PI controller (60MC) measurement value monitoring screen**.



(2) The current measurement value is monitored, and **Measurement data history (cumulative value)** will appear.

The measurement data history per channel and unit price for the last seven days and the current measurement value (the leftmost) will be displayed.

[Date] YY/MM/DD

[Cumulative value]

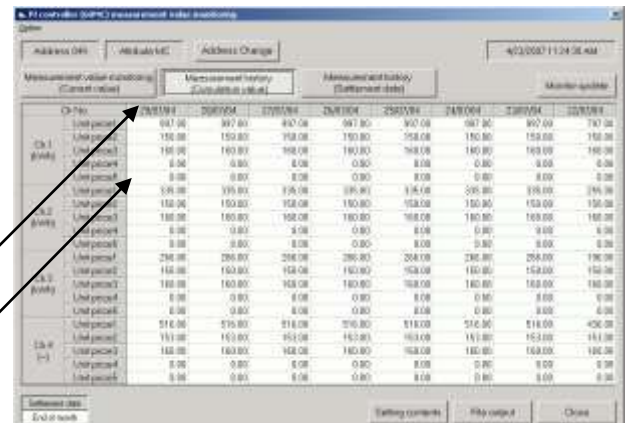

- (3) Click **[Monitor update]** to update the measurement values.
- (4) Click **[File output]** to save the monitored information as a CSV file.
Refer to section [3.15.1.2 Monitoring input/output status on DIDO Controllers (66DC) (5)].
The folder name is **C:\MntToolEA\Data**.
[See section 5.8.]

3.15.3.3 PI Controller (60MC) measurement value Monitor (settlement date)

- (1) Click **[Measurement data history (settlement date)]** in the **PI controller (60MC) measurement value monitoring screen**.



- (2) The current measurement value is monitored, and **Measurement data history (settlement date)** will appear.

The measurement data history per channel and unit price for the last three settlement day will be displayed.

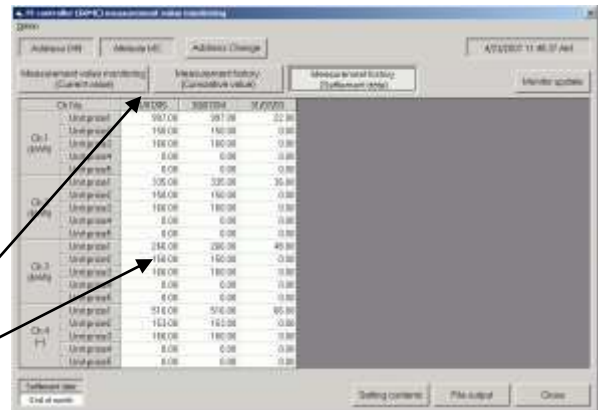

[Date] YY/MM/DD (settlement date)

[Value (settlement date)]

- (3) Click **[Monitor update]** to update the measurement values.
- (4) Click **[File output]** to save the monitored information as a CSV file.
Refer to section [3.15.1.2 Monitoring input/output status on DIDO Controllers (66DC) (5)].
The folder name is **C:\MntToolEA\Data**.
[See section 5.8.]

3.15.3.4 Monitoring of settings on PI Controllers (60MC)

- (1) Click **[Setting contents]** in the **PI controller (60MC) measurement value monitoring screen**.

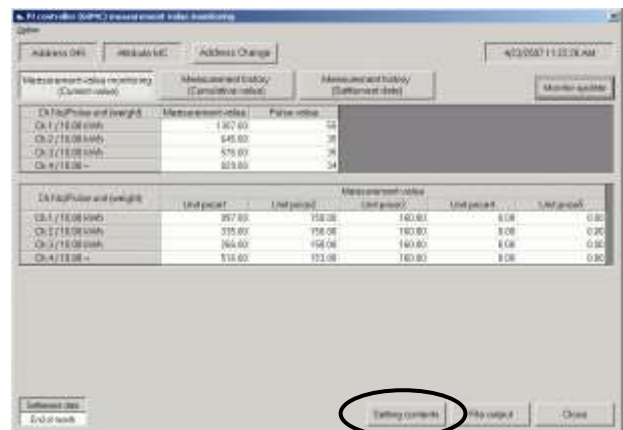

- (2) The setting details are monitored, and **PI controller (60MC) setting screen** will appear. No settings of PI Controller can be made in the Maintenance Tool.

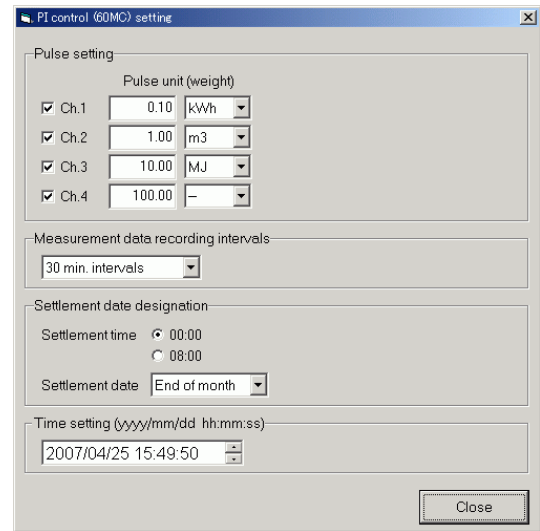

[Pulse unit (weight)]

The pulse unit (weight) and the measurement unit of each channel are shown.

(Unit: kWh, m3, MJ, or – no unit)

[Measurement data recording intervals]

The measurement data recording intervals is shown.

[Settlement time][Settlement date]

The settlement day (month-end, or 1-28th) and the time (0:00 or 8:00) settings are shown.

[Time setting]

The current date and time is shown.

- (3) Click **[Close]** to return to the **PI controller (60MC) measurement value monitoring screen**.

3.15.3.5 Charge time zone setting monitor

- (1) Click **[Option]** in the **PI controller (60MC) measurement value monitoring screen** and select **[Charge time zone setting monitor]** in the sub-menu.

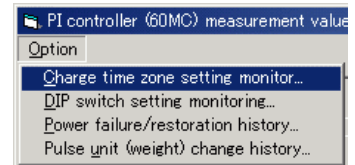

- (2) The charge time zone setting is monitored, and **Charge time zone setting monitor screen** will appear.

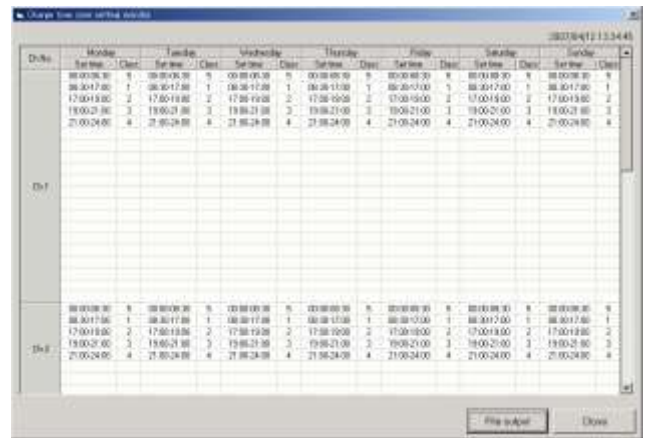

[Set time]

The charge time zone setting is shown.

[Class]

The price class during the set time zone is shown.

- (3) Click **[File output]** to save the monitored information as a CSV file. Refer to section [3.15.1.2 Monitoring input/output status on DIDO Controllers (66DC) (5)].

The folder name is

C:\¥MntTool\EA¥Data.

[See section 5.8.]

- (4) Click **[Close]** to return to the **PI controller (60MC) measurement value monitoring screen**.

3.15.3.6 Monitoring Dip switch setting of PI Controllers

- (1) Click **[Option]** in the **PI controller (60MC) measurement value monitoring screen** and select **[DIP switch setting monitoring]** in the sub-menu.

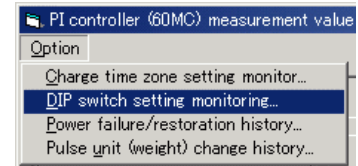

- (2) The DIP switch setting is monitored, and **DIP switch setting monitoring screen** will appear.

* **The pressed (sunken) button shows the current status.**



- (3) Click **[File output]** to save the monitored information as a CSV file. Refer to section [3.15.1.2 Monitoring input/output status on DIDO Controllers (66DC) (5)].

The folder name is

C:¥MntToolEA¥Data.

[See section 5.8.]

- (4) Click **[Close]** to return to the **PI controller (60MC) measurement value monitoring screen**.

3.15.3.7 Power failure/restoration history

- (1) Click **[Option]** in the **PI controller (60MC) measurement value monitoring screen** and select **[Power failure/restoration history]** in the sub-menu.

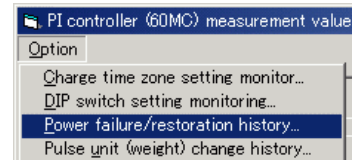

- (2) The power failure/restoration history is monitored, and **Power failure/restoration history screen** will appear. Up to 20 of the latest data can be displayed.

[Date/Time]

The date and time when power failure/restoration occurs is shown.

[Power supply status]

The status, power failure or power restoration, is shown.

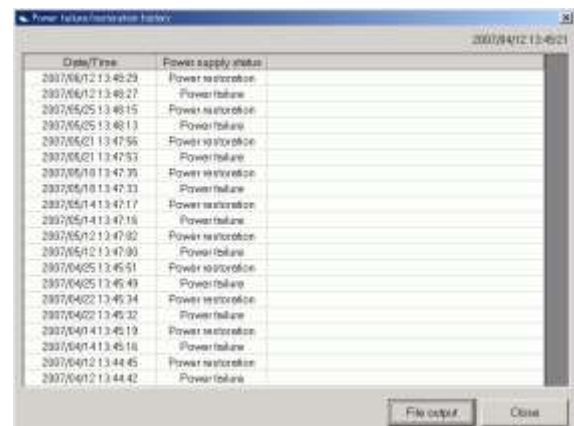

- (3) Click **[File output]** to save the monitored information as a CSV file. Refer to section [3.15.1.2 Monitoring input/output status on DIDO Controllers (66DC) (5)].

The folder name is

C:¥MntToolEA¥Data.

[See section 5.8.]

- (4) Click **[Close]** to return to the **PI controller (60MC) measurement value monitoring screen**.

3.15.3.8 Pulse unit (weight) change history

- (1) Click **[Option]** in the **PI controller (60MC) measurement value monitoring screen** and select **[Pulse unit (weight) change history]** in the sub-menu.

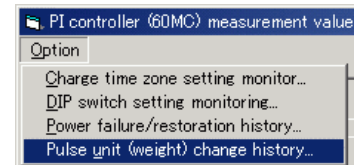

- (2) The pulse unit (weight) change history is monitored, and **Pulse unit (weight) change history screen** will appear. Up to 10 of the latest data can be displayed.

[Date/Time]

The date and time when the pulse unit (weight) is changed is shown.

[Ch No.]

The channel on which the pulse unit (weight) is changed is shown.

[Pulse unit (weight)]

The pulse unit (weight) after the change has been made is shown.

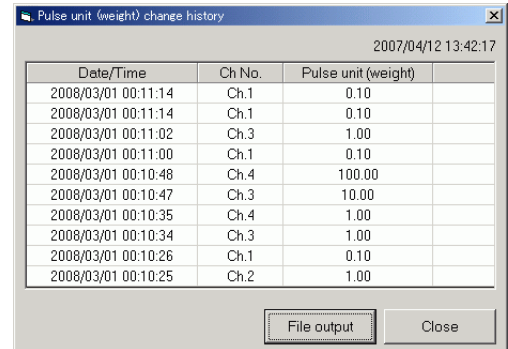

The screenshot shows a window titled "Pulse unit (weight) change history" with a timestamp of 2007/04/12 13:42:17. It contains a table with the following data:

Date/Time	Ch No.	Pulse unit (weight)
2008/03/01 00:11:14	Ch.1	0.10
2008/03/01 00:11:14	Ch.1	0.10
2008/03/01 00:11:02	Ch.3	1.00
2008/03/01 00:11:00	Ch.1	0.10
2008/03/01 00:10:48	Ch.4	100.00
2008/03/01 00:10:47	Ch.3	10.00
2008/03/01 00:10:35	Ch.4	1.00
2008/03/01 00:10:34	Ch.3	1.00
2008/03/01 00:10:26	Ch.1	0.10
2008/03/01 00:10:25	Ch.2	1.00

At the bottom of the window, there are two buttons: "File output" and "Close".

- (3) Click **[File output]** to save the monitored information as a CSV file. Refer to section [3.15.1.2 Monitoring input/output status on DIDO Controllers (66DC) (5)]. The folder name is **C:¥MntToolEA¥Data**. [See section 5.8.]
- (4) Click **[Close]** to return to the **PI controller (60MC) measurement value monitoring screen**.

3.15.4 Interlock control settings on DIDO Controllers (66DC)

DIDO Controllers (PAC-YG66DCA) can control the following items of M-NET devices or the contacts on DIDO Controllers depending on the change in input contact status.

- *DIDO Controller: contact output
- *Indoor unit: start/stop control
- *Indoor unit: operation mode change
- *Indoor unit: temperature setting

The interlock control settings can be made on Maintenance Tool. (Max. 24 patterns)

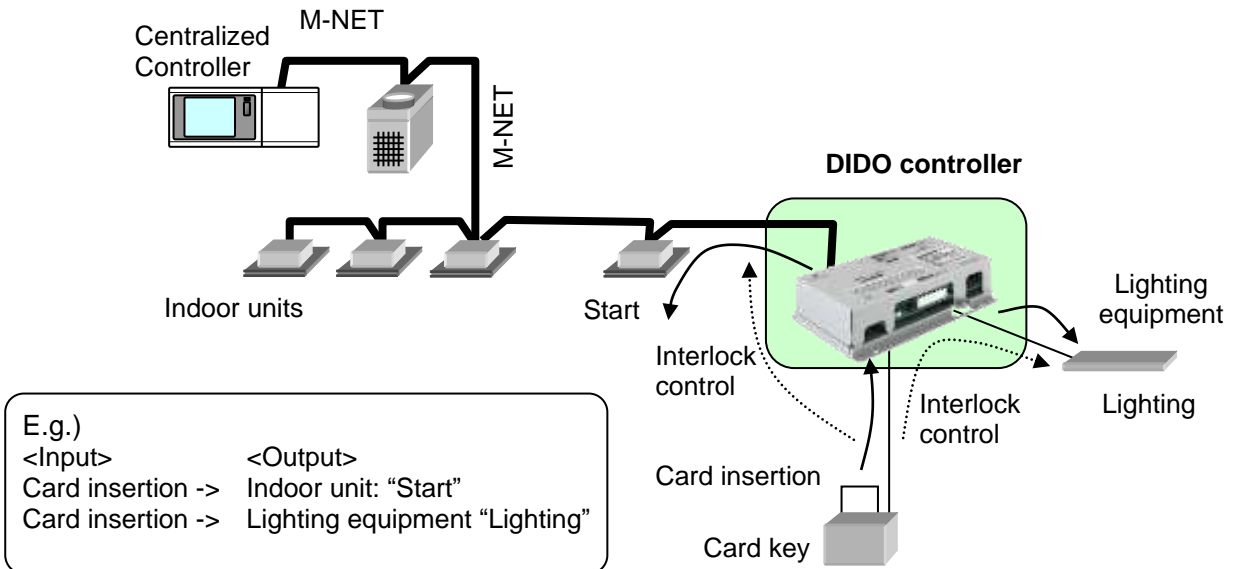

Caution:

Before using the interlock control, you must agree to the following.

1. This feature must not be used for disaster prevention or security purposes. (Not designed to be used in situations that are life-threatening)
2. No functions must be added that allow the malfunctioning unit to run by defeating the safety features, such as an external ON/OFF switch or a short-circuit.
3. Those settings for the function that are not supported by the interlocked units must not be made. All the settings must be made within the specified range. (Failure to observe these precautions may result in malfunctions and failures.)
4. Perform a test run for interlock control, and confirm the correct settings and normal operation.
5. The system must be configured in the way that integrates the operation of the interlocked fire and emergency control systems.

3.15.4.1 Starting the interlock control settings on DIDO Controllers

The password is needed to make the settings for interlock control. Only the allowed administrator can perform the settings. To make the settings, enter the password first to be identified as an administrator. The procedures are shown below. The setting procedures are the same for AI Controllers.

- (1) Click **[Option]** in the menu bar and select **[DIDO/AI/PI] -> [Interlock control option]** in the sub-menu.



- (2) **Interlock control option screen** will appear.

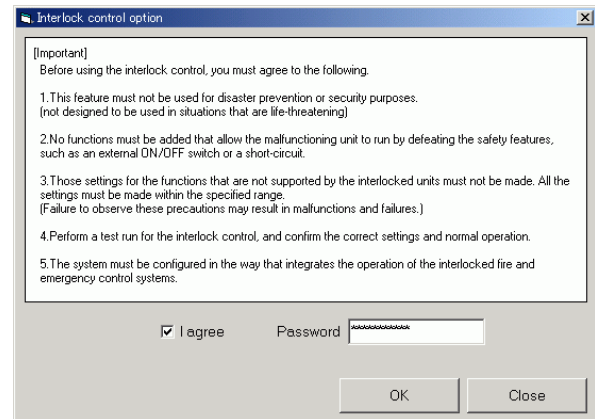

- (3) Click the checkbox of **[I agree]** to accept the agreement.

Caution:
Read the agreement carefully.

- (4) Enter the password.
- (5) Click **[OK]**.

- (6) **"Do you want to enable the DIDO/AI interlock setting?"** will appear, click **[Yes]**.

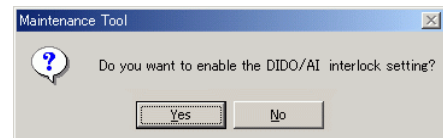

- (7) **"DIDO/AI interlock setting has been enabled."** will appear, click **[OK]**.



- (8) **[DIDO/AI interlock setting]** in **[DIDO/AI/PI]** sub-menu becomes active, and the settings can be made.

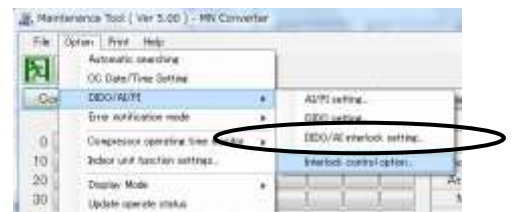

NOTE:
[DIDO/AI interlock setting] will be kept active once it becomes active. To make it inactive, enter the password to make a inactivation on the interlock control option screen [Refer to 3.15.4.1 (4)].

3.15.4.2 Interlock control settings on DIDO Controllers

- (1) Click **[Option]** in the menu bar and select **[DIDO/AI/PI] -> [DIDO/AI interlock setting]** in the sub-menu.



- (2) Click **[DC]** of the unit (DIDO Controller) to be monitored on the **Main screen**.

- (3) **DIDO controller (66DC) Interlock control setting screen** will appear.

Caution:
Read the agreement carefully.

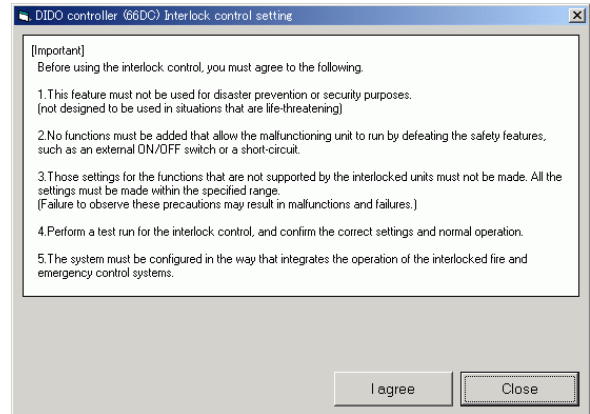

- (4) Click the checkbox of **[I agree]** to accept the agreement.

- (5) The interlock control settings is monitored, and **DIDO controller (66DC) Interlock control setting screen** will appear.

[Interlock No.]

The pattern No. of interlock control setting is shown. Up to 24 patterns can be set.

<Input>

[Ch No.][Interlock operation conditions]

The input Ch No. of the interlock source and the interlock condition (operation, stop, error occurrence, error reset) are shown.

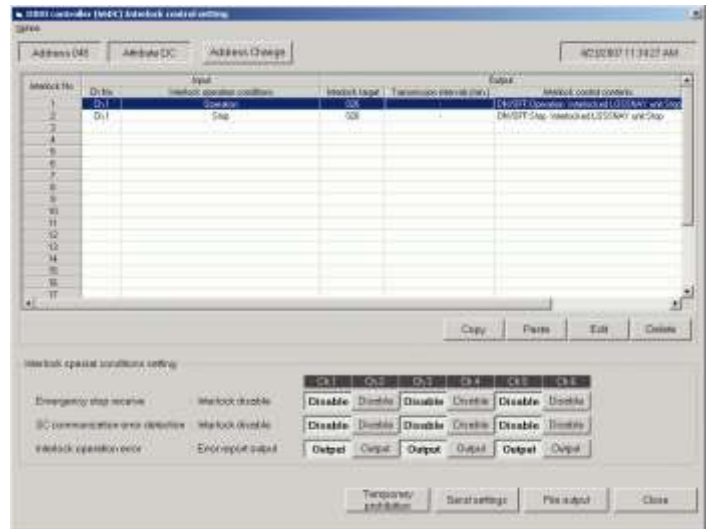

<Output>

[Interlock target]

The unit address of the interlock target is shown.

When the contact on the DIDO Controller is output, the channel No. to be output is shown.

[Transmission intervals (min.)]

“-“ is shown. (not to be used)

[Interlock control contents]

Interlock operation (start/stop etc.) is shown.

<Interlock special condition setting>

[Emergency stop receive: Interlock disable]

When the emergency stop command is received from Centralized Controller, whether to enable or disable the interlock operation depending on the change in input contact status can be set for each channel.

* The **pressed (sunken) button** shows the currently **“Disable”** status.

The interlock operation will be disabled for 15 minutes on the input channel on which “Disable” is set after the emergency stop command is received from Centralized Controller. Unless the emergency stop command is received again within 15 minutes, the “Interlock disable” will be inactive after 15 minutes have passed.

For your safety, “Disable” is set (default) to all channels. However, the setting can be changed on the unit that is required to be run at emergency. Consider carefully how the unit is required to be run at emergency, and make the proper setting.

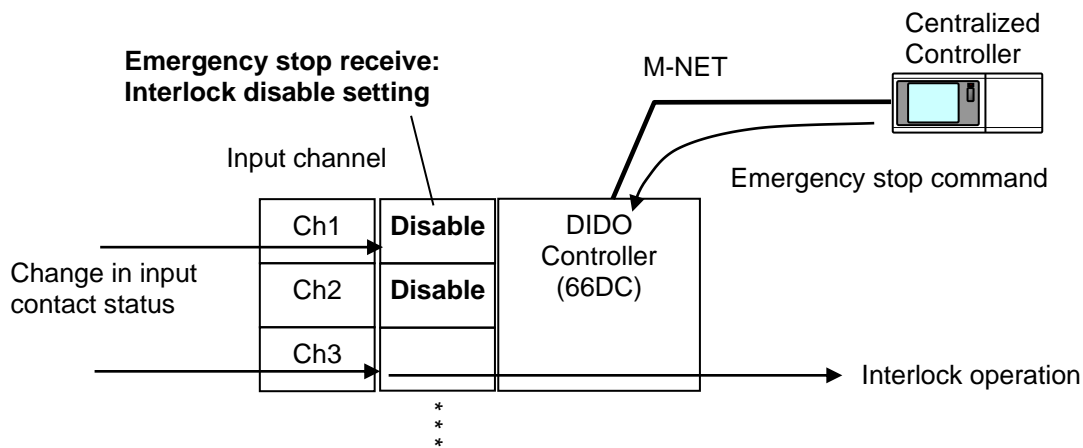

[SC communication error detection: Interlock disable]

When the communication error with Centralized Controller occurs, whether to enable or disable the interlock operation depending on the change in input contact status can be set for each channel.

* The **pressed (sunken) button** shows the currently **“Disable”** status.

The interlock operation will be disabled on the input channel on which “Disable” is set when the communication error with Centralized Controller occurs.

When the communication error with Centralized Controller is reset, the “Interlock disable” will be inactive.

For your safety, “Disable” must be set when no means (such as local remote controllers) is available to stop the operation of the interlock target unit.

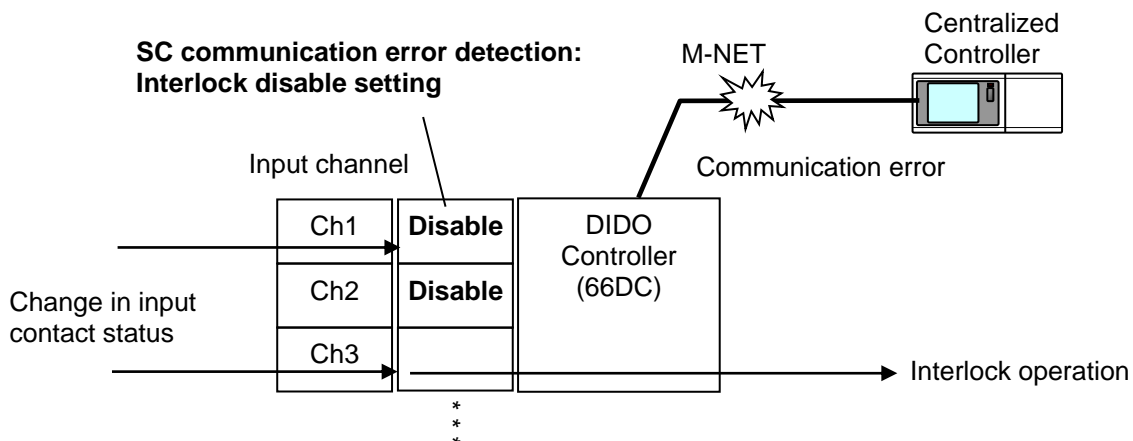

[Interlock operation error: Error report output]

When the interlock control with the M-NET device is failed (when no response to the interlock operation command is received from the M-NET device), Whether to output or doesn't output the error report can be set for each output channel.

* The **pressed (sunken) button** shows the currently **“Output”** status.

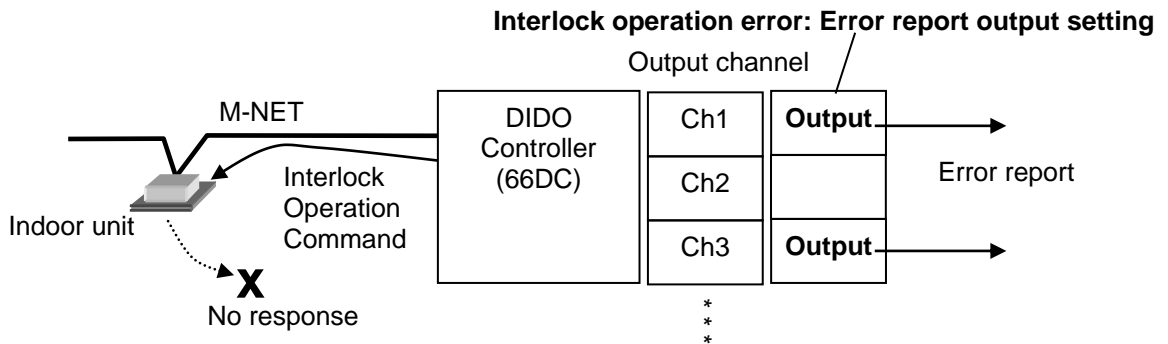

(6) Select the line to be set, and click **[Edit]**.

To copy the preset interlock setting, select the line to be copied, and click **[Copy]**, then select the line to be pasted, and click **[Paste]**.

To delete the setting, select the line to be deleted, and click **[Delete]**.

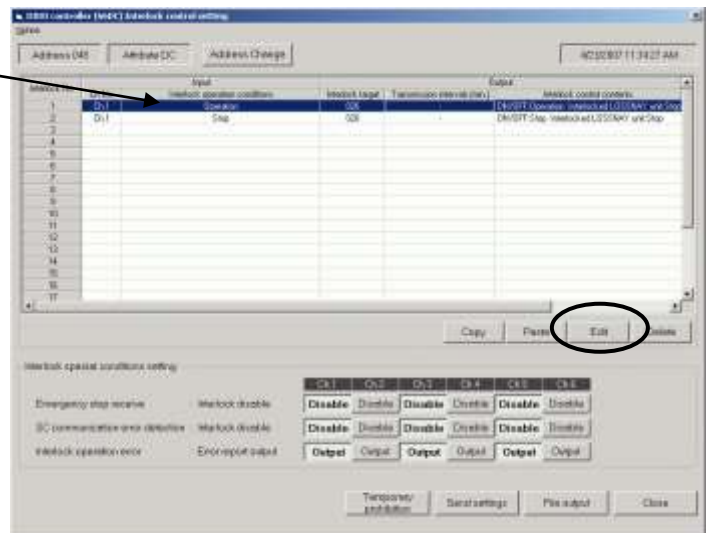

(7) **DIDO controller (66DC) Interlock control setting screen** will appear.

[Interlock No.]

The pattern No. of interlock control setting is shown.

[Ch No.]

Set the input Ch No. of interlock source.

[Interlock operation conditions]

Set the interlock condition (operation, stop, error occurrence, error reset) of the input channel (Ch No.) of the interlock source.



[Interlock target]

Select the unit address to be controlled.

When the contact on the DIDO Controller is output, select the address of the DIDO Controller.

Select one of the following operations by clicking a radio button.

* The **pressed (sunken) button** shows the currently **“Enabled”** status.

* **[DIDO operation]**

Select the channel to be output, and set whether to **[Operation]** or **[Stop]** the selected channel.

* **[ON/OFF]**

Set the start/stop control of the indoor unit.

Even when the LOSSNAY unit is not interlocked with the indoor unit, one of the operation mode buttons of [Interlocked LOSSNAY unit] must be set to **“Enabled”**.

* **[Mode]**

Set the operation mode of the indoor unit.

* **[Set temp.]**

Set the set temperature of the indoor unit.(19°C – 28°C)

Caution:
Only make the interlock settings for the functions that are supported by the unit to be interlocked. Making the interlock setting for functions that are not supported may result in malfunctions or failures.

(8) Click **[OK]**.

(9) The screen will return to the **DIDO controller (66DC) Interlock control setting screen**.

(* The settings have not been saved yet.)

(10) Repeat the steps between (6) and (9).

(11) Select the **[Disable]** or **[Output]** of each channel for each setting item, **[Emergency stop receive: Interlock disable], [SC communication error detection: Interlock disable] and [Interlock operation error: Error report output]**.

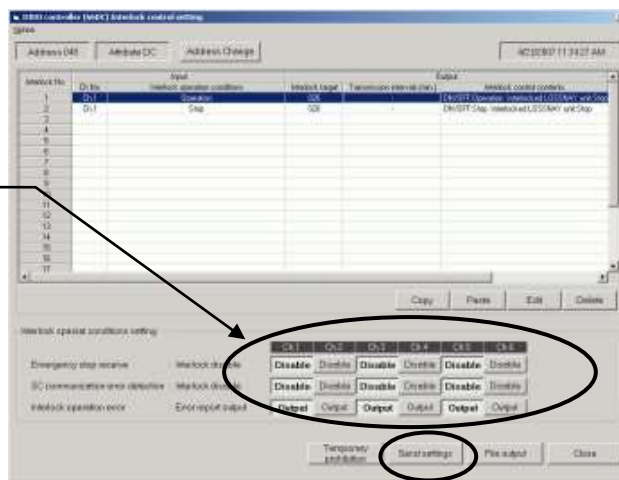

(12) Click **[Send settings]**.

(13) **“Settings will be sent. OK?”** will appear, click **[Yes]**.
The setting will be applied to the unit.

(14) **“Settings have been sent.”**will appear, click **[OK]**.

(15) Click **[Close]** to return to the **Main screen**.

NOTE:
When you use Fahrenheit for the unit, there might be differences of the plus or minus 0.1 °F in the set value and the value monitored after it sets it.

NOTE:

If there are several patterns of the same input channel and interlock operation conditions, **the interlock control operation will be output in the ascending order of the interlock operation No.**

Note the order when setting the same interlock operation conditions patterns.

To output several interlock control operations under the same input interlock operation conditions, make the following settings.

E.g.)

<Input interlock operation condition>

[Ch No.] 1 [Interlock operation conditions] Error occurrence

When following three interlock control operations are output under the above interlock operation condition.

<Interlock control operation output>

[Interlock target] 001 (Indoor unit: address 01)

The interlock control is output in the following order.

[ON/OFF] Operation, **Interlocked LOSSNAY unit:** Run (Low)

[Mode] Cool

[Set temp.] 25°C

[Interlock No.] 1 [Ch No.] 1 [Interlock operation conditions] Error occurrence

[Interlock target] 001 **[ON/OFF]** Operation,

Interlocked LOSSNAY unit: Run (Low)

[Interlock No.] 2 [Ch No.] 1 [Interlock operation conditions] Error occurrence

[Interlock target] 001 **[Mode]** Cool

[Interlock No.] 3 [Ch No.] 1 [Interlock operation conditions] Error occurrence

[Interlock target] 001 **[Set temp.]** 25°C

The interlock control operation is output in the order of No.1, 2 and 3.

3.15.4.3 Temporary interlock prohibition setting

(1) Click [Temporary prohibition].

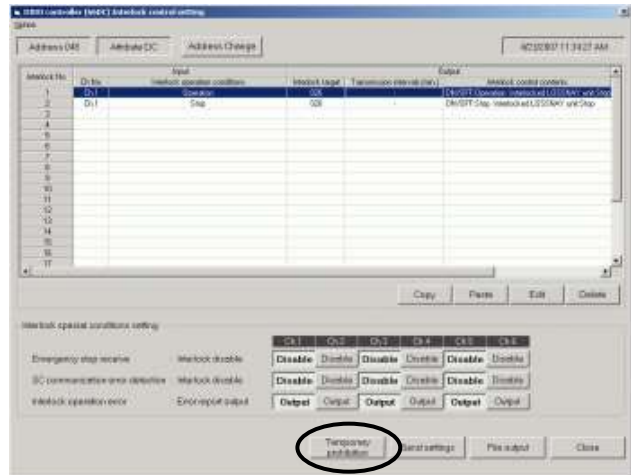

(2) Temporary interlock prohibition setting screen will appear.

* The pressed (sunken) button shows the current status.

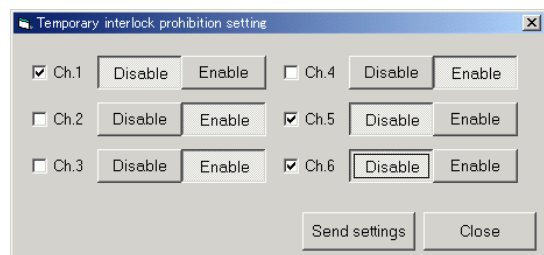

(3) Click the checkbox of the channel to be changed, and select [Disable] or [Enable].

(4) Click [Send settings].

(5) "Settings will be sent. OK?" will appear, click [Yes].
The setting will be applied to the unit.

(6) "Settings have been sent." will appear, click [OK].

NOTE:

The "disable temporary interlock control (prohibition)" will be active for 15 minutes after the setting has been sent, and will be inactive after 15 minutes have passed.

When the setting is sent again within 15 minutes before the "disable temporary interlock control" becomes inactive, the "disable temporary interlock control" will be active again for another 15 minutes.

When the "enable temporary interlock control" setting is sent during the "disable temporary interlock control" within 15 minutes, the "disable temporary interlock control" will be inactive.

(7) Click [Close] to return to the **DIDO controller (66DC) Interlock control setting screen.**

3.15.4.4 Saving the interlock control settings on DIDO Controllers (66DC) in CSV format

- Click **[File output]** to save the interlock control settings as a CSV file.
Refer to section [3.15.1.2 Monitoring input/output status on DIDO Controllers (66DC) (5)].
The folder name is **C:\MntToolEA\Data**.
[See section 5.9.]

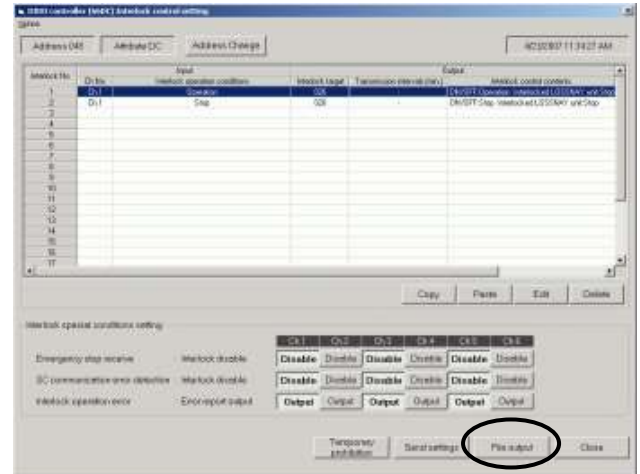

- Click **[Close]** to return to the **Main screen**.

3.15.4.5 DIDO Controller interlock operation history

- Click **[Option]** in the menu bar and select **[Interlock operation history]**

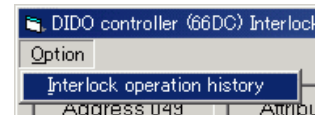

- The interlock operation history is monitored, and **Interlock operation history screen** will appear.
Up to 100 of the latest data can be displayed.

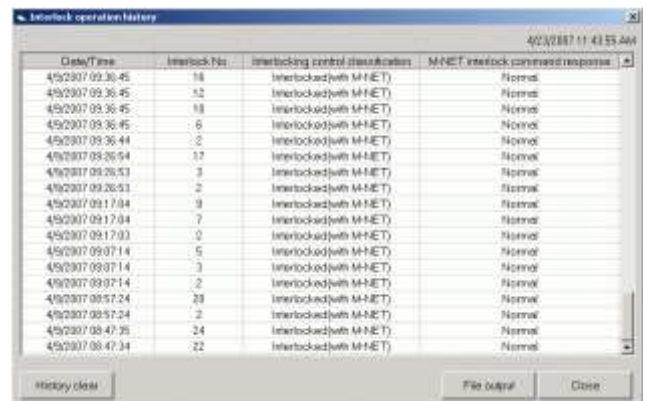

[Date/Time]

The date and time when the interlock control is made is shown.

[Interlock No.]

The pattern No. of interlock control setting is shown. [Refer to section 3.15.4.2.]

[Interlock operation type]

The interlock target (M-NET device or contact on DIDO Controller) is shown.

[M-NET interlock command response]

When a response is received from the M-NET device to be interlocked, **“Normal”** is shown.

When no response is received, **“Error”** is shown.

When the interlock operation type is “Interlocked with contact”, **“-“** is shown.

- Click **[History clear]** to clear the interlock operation history.
Refer to section [3.15.2.6 Out-of-limit alarm history (4)].
- Click **[File output]** to save the interlock operation history as a CSV file.
Refer to section [3.15.1.2 Monitoring input/output status on DIDO Controllers (66DC) (5)].
The folder name is **C:\MntToolEA\Data**.
[See section 5.9.]
- Click **[Close]** to return to the **DIDO controller (66DC) Interlock control setting screen**.

3.15.5 Interlock control settings on AI Controllers

AI Controllers (PAC-YG63MCA) can control the following items of M-NET devices depending on the measurement values measured by AI Controllers.

- *Indoor unit: start/stop control
- *Indoor unit: operation mode change
- *Indoor unit: temperature setting

The interlock control settings can be made on Maintenance Tool. (Max. 24 patterns)

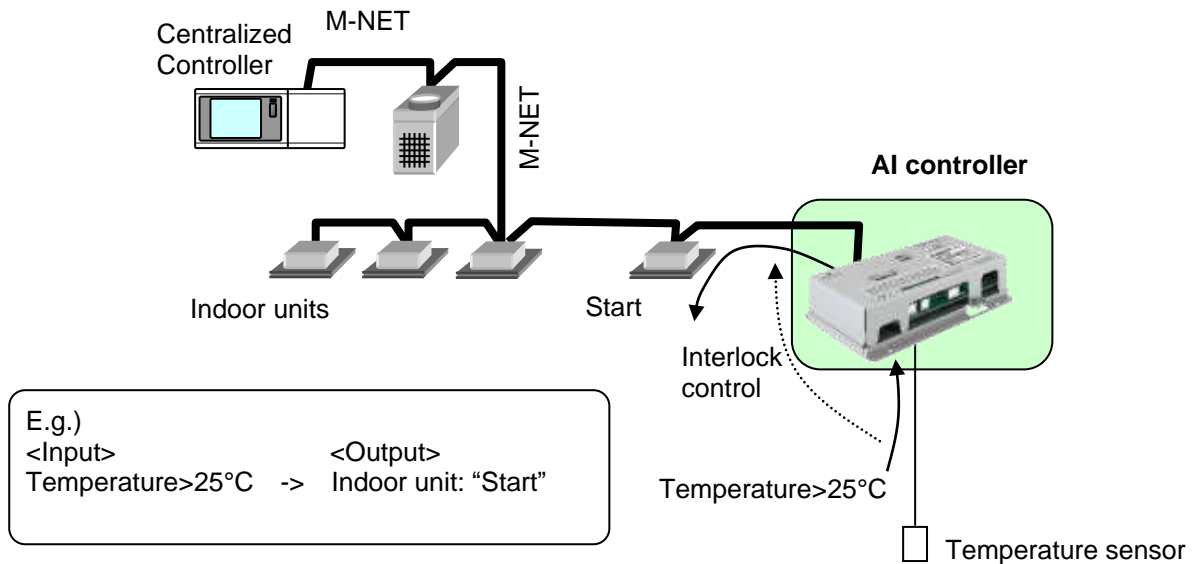

Caution:

Before using the interlock control, you must agree to the following.

1. This feature must not be used for disaster prevention or security purposes. (Not designed to be used in situations that are life-threatening)
2. No functions must be added that allow the malfunctioning unit to run by defeating the safety features, such as an external ON/OFF switch or a short-circuit.
3. Those settings for the function that are not supported by the interlocked units must not be made. All the settings must be made within the specified range. (Failure to observe these precautions may result in malfunctions and failures.)
4. Perform a test run for interlock control, and confirm the correct settings and normal operation.
5. The system must be configured in the way that integrates the operation of the interlocked fire and emergency control systems.

3.15.5.1 Starting the interlock control settings on AI Controllers

The password is needed to make the settings for interlock control. Only the allowed administrator can perform the settings. To make the settings, enter the password first to be identified as an administrator. The procedures are shown below. The setting procedures are the same for DIDO Controllers. Refer to section [3.15.4.1 Starting the interlock control settings on DIDO Controllers].

3.15.5.2 Interlock control settings on AI Controllers

(1) Click **[Option]** in the menu bar and select **[DIDO/AI/PI] -> [DIDO/AI interlock setting]** in the sub-menu.

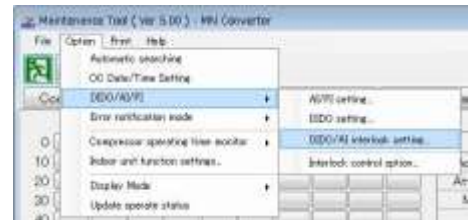

(2) Click **MC** of the unit (AI Controller) to be monitored on the **Main screen**.

(3) **AI controller (63MC) interlock control setting screen** will appear.

Caution:
Read the agreement carefully.

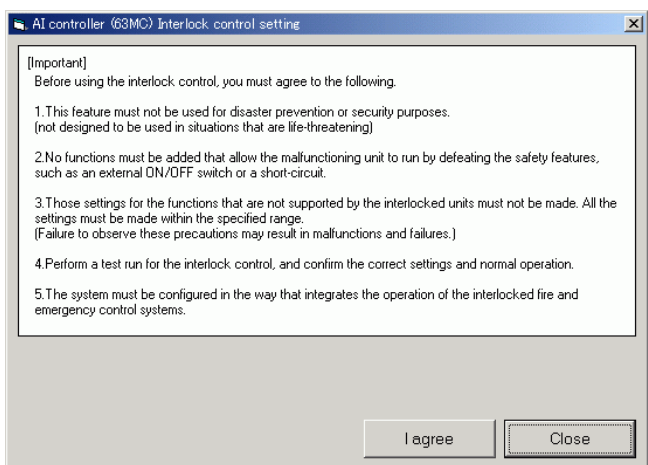

(4) Click the checkbox of **[I agree]** to accept the agreement.

(5) The interlock control settings is monitored, and **AI controller (63MC) interlock control setting screen** will appear.

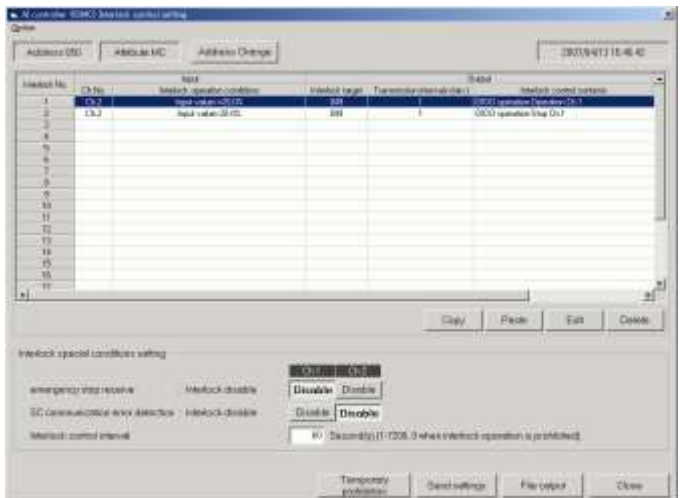

[Interlock No.]

The pattern No. of interlock control setting is shown. Up to 24 patterns can be set.

<Input>

[Ch No.][Interlock operation conditions]

The Ch No. of the interlock source and the interlock condition (condition based on the measurement value) are shown.

<Output>

[Interlock target]

The unit address of the interlock target is shown.

[Transmission intervals (min.)]

As long as the input interlock condition is met, the interlock control operation will keep being output continuously at the set intervals.

E.g.) When the following input interlock condition is set
input value>25°C, Transmission intervals (min.): 10 min., Interlock control contents: Operation

As long as the measurement value keeps 26°C, the “operation ON” command will keep being sent at 10 minute intervals even when the air-conditioner is once turned off by a local remote controller.

[Interlock control contents]

Interlock operation (start/stop etc.) is shown.

<Interlock special condition setting>

[Emergency stop receive: Interlock disable]

When the emergency stop command is received from Centralized Controller, whether to enable or disable the interlock operation depending on the change in measurement values can be set for each channel.

* The **pressed (sunken) button** shows the currently “Disable” status.

The interlock operation will be disabled for 15 minutes on the input channel on which “Disable” is set after the emergency stop command is received from Centralized Controller. Unless the emergency stop command is received again within 15 minutes, the “Interlock disable” will be inactive after 15 minutes have passed.

For your safety, “Disable” is set (default) to all channels. However, the setting can be changed on the unit that is required to be run at emergency. Consider carefully how the unit is required to be run at emergency, and make the proper setting.

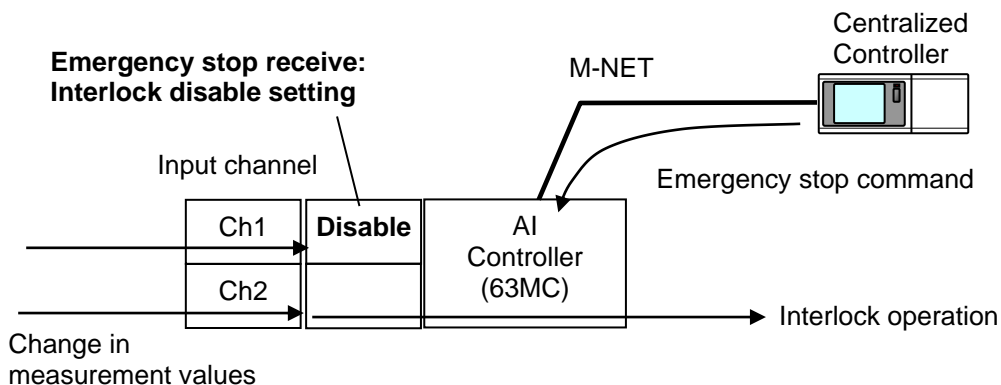

[SC communication error detection: Interlock disable]

When the communication error with Centralized Controller occurs, whether to enable or disable the interlock operation depending on the change in measurement values can be set for each channel.

* The **pressed (sunken) button** shows the currently “Disable” status.

The interlock operation will be disabled on the input channel on which “Disable” is set when the communication error with Centralized Controller occurs.

When the communication error with Centralized Controller is reset, the “Interlock disable” will be inactive.

For your safety, “Disable” must be set when no means (such as local remote controllers) is available to stop the operation of the interlock target unit.

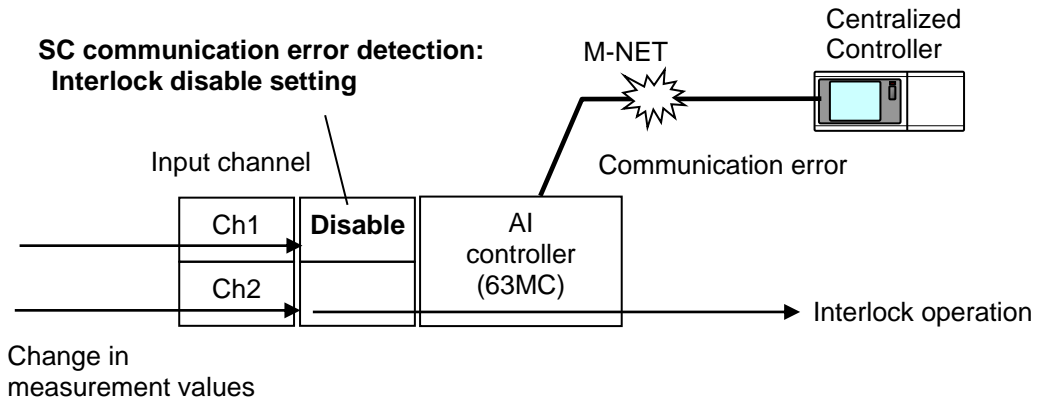

[Interlock control interval]

Whether the interlock condition is met is determined at the set intervals depending on the monitored current value.

E.g.) When the interlock control intervals is set to 60 seconds

Whether the interlock condition is met is determined at 60 second intervals depending on the monitored current value. The interlock control operation will be output when the interlock condition is met.

(6) Select the line to be set, and click **[Edit]**.

To copy the preset interlock setting, select the line to be copied, and click **[Copy]**, then select the line to be pasted, and click **[Paste]**.

To delete the setting, select the line to be deleted, and click **[Delete]**.

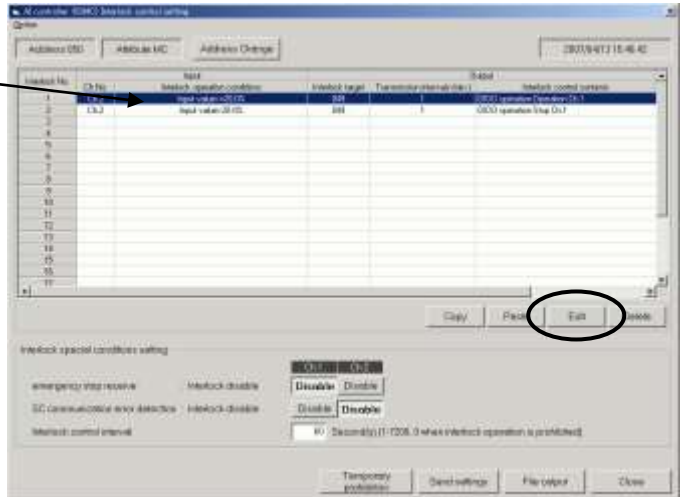

(7) **AI controller (63MC) interlock control setting screen** will appear.

[Interlock No.]

The pattern No. of interlock control setting is shown.

[Ch No.]

Set the input Ch No. of interlock source.

[Input conditions]

Set the interlock condition of the interlock source input channel (Ch No.).

Select the comparison relation between the input value and the upper/lower threshold.

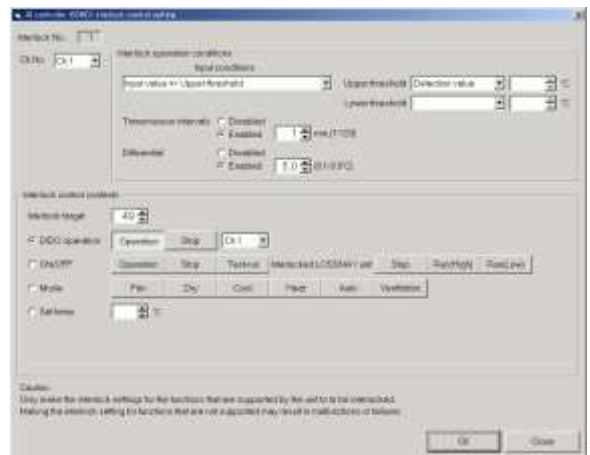

[Upper threshold][Lower threshold]

The upper/lower threshold to use for input conditions can be set.

Select one among “**Detection value**”, “**Cancellation value**”, or “**Manual setting**”.

When the “**Detection value**” is selected, the upper/lower limit alarm detection of the interlock source (AI Controller) will be applied.

[See section 3.15.2.2. Setting for AI Controllers (63MC) (2)]

When the “**Cancellation value**” is selected, the upper/lower limit alarm cancellation of the interlock source (AI Controller) will be applied.

[See section 3.15.2.2. Setting for AI Controllers (63MC) (2)]

When the “**Manual setting**” is selected, enter the value in the box on the right within the measurement range (between the upper and the lower limit values) of the interlock source (AI Controller).

[See section 3.15.2.2. Setting for AI Controllers (63MC) (2)]

[Transmission intervals]

As long as the input interlock condition is met, the interlock control operation will keep being output continuously at the set intervals.

Select “**Disabled**” or “**Enabled**”. When “**Enabled**” is selected, set the value. (1-120 min.)

[Differential]

(This setting can be made only when “**Enable**” is selected in the **[Data transmission intervals]**.)

The “**differential**” can be set.

Select “**Disabled**” or “**Enabled**”. When “**Enabled**” is selected, set the value. (0.1-9.9°C /°F /%)

Make this setting to keep outputting the same interlock control operation preventing other interlock control operations from being output when the input value remains around the upper/lower thresholds.

As long as the interlock condition is met, the interlock control operation is output under the set interlock condition (including the set differential). The differential is not available for the first case.

To make the differential valid, make the differentials of all the channels the same.

[Interlock target]

Select the unit address to be controlled.

Select one of the following operations by clicking a radio button.

* The **pressed (sunken) button** shows the currently **“Enabled”** status.

* **[DIDO operation]**

Select the channel to be output, and set whether to **[Operation]** or **[Stop]** the selected channel.

* **[ON/OFF]**

Set the start/stop control of the indoor unit.

Even when the LOSSNAY unit is not interlocked with the indoor unit, one of the operation mode buttons of [Interlocked LOSSNAY unit] must be set to **“Enabled”**.

* **[Mode]**

Set the operation mode of the indoor unit.

* **[Set temp.]**

Set the set temperature of the indoor unit. (19°C – 28°C)

Caution:

Only make the interlock settings for the functions that are supported by the unit to be interlocked. Making the interlock setting for functions that are not supported may result in malfunctions or failures.

(8) Click **[OK]**.

(9) The screen will return to the **AI controller (63MC) interlock control setting screen**.

(* The settings have not been saved yet.)

(10) Repeat the steps between (6) and (9).

(11) Select the **[Disable]** or **[Output]** of each channel for each setting item, **[Emergency stop receive: Interlock disable]**, **[SC communication error detection: Interlock disable]** and **[Interlock control interval]**.

(12) Click **[Send settings]**.

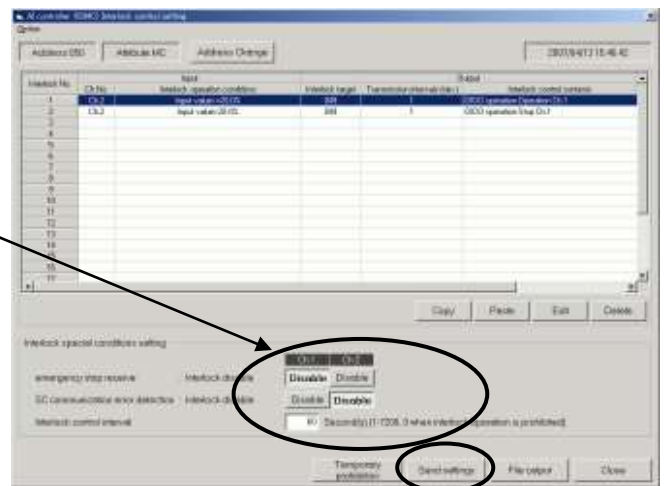

(13) **“Settings will be sent. OK?”**

will appear, click **[Yes]**.

The setting will be applied to the unit.

(14) **“Settings have been sent.”** will appear, click **[OK]**.

(15) Click **[Close]** to return to the **Main screen**.

NOTE:

If there are several patterns of the same input channel and interlock operation conditions, **the interlock control operation will be output in the ascending order of the interlock operation No.**

Note the order when setting the same interlock operation conditions patterns.

To output several interlock control operations under the same input interlock operation conditions, make the following settings.

E.g.)

<Input interlock operation condition>

[Ch No.] 1 [Interlock operation conditions] Input value>25°C

When following three interlock control operations are output under the above interlock operation condition.

<Interlock control operation output>

[Interlock target] 001 (Indoor unit: address 01)

The interlock control is output in the following order.

[ON/OFF] Operation, **Interlocked LOSSNAY unit:** Run (Low)

[Mode] Cool

[Set temp.] 23°C

[Interlock No.] 1 [Ch No.] 1 [Interlock operation conditions] Input value>25°C

[Interlock target] 001 **[ON/OFF]** Operation,

Interlocked LOSSNAY unit: Run (Low)

[Interlock No.] 2 [Ch No.] 1 [Interlock operation conditions] Input value>25°C

[Interlock target] 001 **[Mode]** Cool

[Interlock No.] 3 [Ch No.] 1 [Interlock operation conditions] Input value>25°C

[Interlock target] 001 **[Set temp.]** 23°C

The interlock control operation is output in the order of No.1, 2 and 3.

The interlock control No. does not have to be consecutive;

however it is recommended to set the consecutive No. to avoid mistakes in the setting.

NOTE:

When you use Fahrenheit for the unit, there might be differences of the plus or minus 0.1 °F in the set value and the value monitored after it sets it.

3.15.5.3 Temporary interlock prohibition setting

(1) Click **[Temporary prohibition]**.

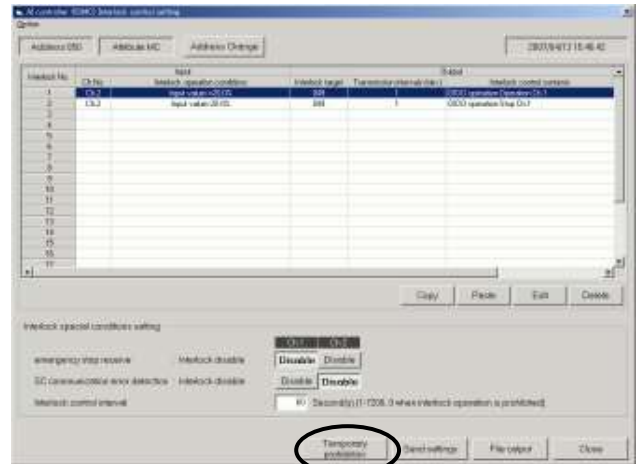

(2) **Temporary interlock prohibition setting screen** will appear.

* **The pressed (sunken) button** shows the current status.



(3) Click the checkbox of the channel to be changed, and select **[Disable]** or **[Enable]**.

(4) Click **[Send settings]**.

(5) **"Settings will be sent. OK?"** will appear, click **[Yes]**.
The setting will be applied to the unit.

(6) **"Settings have been sent."** will appear, click **[OK]**.

NOTE:

The "disable temporary interlock control (prohibition)" will be active for 15 minutes after the setting has been sent, and will be inactive after 15 minutes have passed.

When the setting is sent again within 15 minutes before the "disable temporary interlock control" becomes inactive, the "disable temporary interlock control" will be active again for another 15 minutes.

When the "enable temporary interlock control" setting is sent during the "disable temporary interlock control" within 15 minutes, the "disable temporary interlock control" will be inactive.

(7) Click **[Close]** to return to the **AI controller (63MC) interlock control setting screen**.

3.15.5.4 Saving the interlock control settings on AI Controllers (63MC) in CSV format

- (1) Click **[File output]** to save the interlock control settings as a CSV file.
Refer to section [3.15.1.2 Monitoring input/output status on DIDO Controllers (66DC) (5)].
The folder name is **C:\MntToolEA\Data**.
[See section 5.9.]

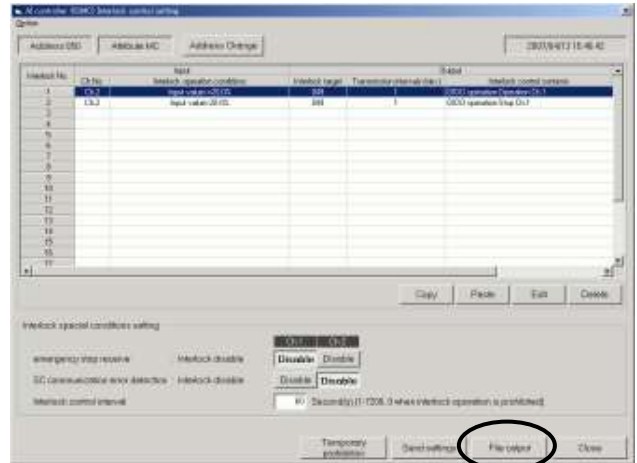

- (2) Click **[Close]** to return to the **Main screen**.

3.15.5.5 AI Controller interlock operation history

- (1) Click **[Option]** in the menu bar and select **[Interlock operation history]**

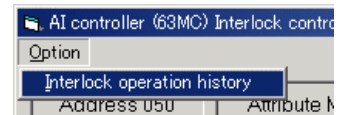

- (2) The interlock operation history is monitored, and **Interlock operation history screen** will appear.
Up to 100 of the latest data can be displayed.

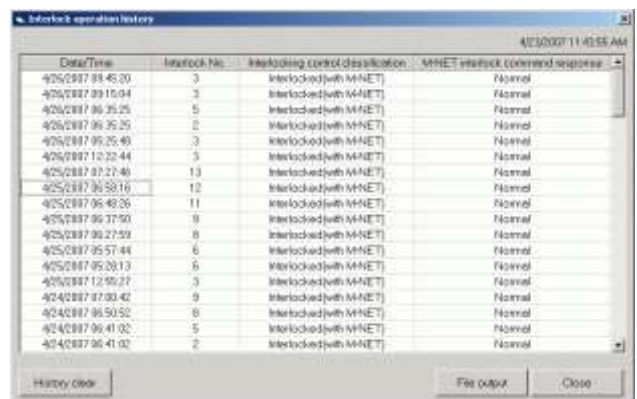

[Date/Time]

The date and time when the interlock control is made is shown.

[Interlock No.]

The pattern No. of interlock control setting is shown. [Refer to section 3.15.5.2.]

[Interlock operation type]

The interlock target (only the “Interlocked(with M-NET)” here) is shown.

[M-NET interlock command response]

When a response is received from the M-NET device to be interlocked, “**Normal**” is shown.

When no response is received, “**Error**” is shown.

When the interlock operation type is “Interlocked with contact”, “-“ is shown.

- (3) Click **[History clear]** to clear the interlock operation history.
Refer to section [3.15.2.6 Out-of-limit alarm history (4)].
- (4) Click **[File output]** to save the interlock operation history as a CSV file.
Refer to section [3.15.1.2 Monitoring input/output status on DIDO Controllers (66DC) (5)].
The folder name is **C:\MntToolEA\Data**.
[See section 5.9.]
- (5) Click **[Close]** to return to the **AI controller (63MC) interlock control setting screen**.

3.16 Setting the Values for Indoor unit Functions

*** Features**

- The preset values for each function of the connected indoor units can be displayed.
- The preset values for each function of the connected indoor units can be set or changed.

NOTE:
The function mentioned here is not available to the models that do not support this function.

3.16.1 Start-up

- (1) Start-up sequence
 - a) Click **[Option (O)]** of the menubar in the **[On-Line Main] Screen**, and click **[Indoor unit function settings]** of the submenu.
 - b) The **[Indoor unit function settings]** screen is displayed.

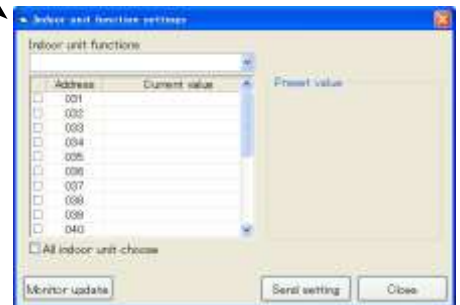
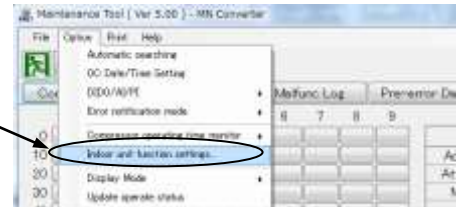

3.16.2 Monitoring the preset value

- (1) Select the function whose preset value is to be monitored from the list of **[Indoor unit functions]**.
 - a) Click **[▼]** next to **[Indoor unit functions]**.
 - b) Select the desired function from the list of functions that appears.
 - c) The selected function will appear under **[Indoor unit functions]**.

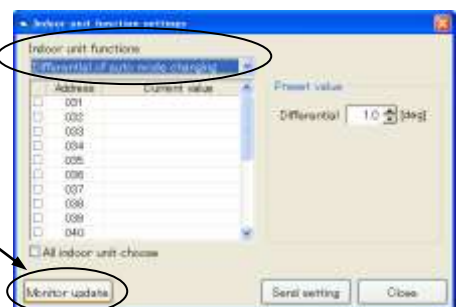
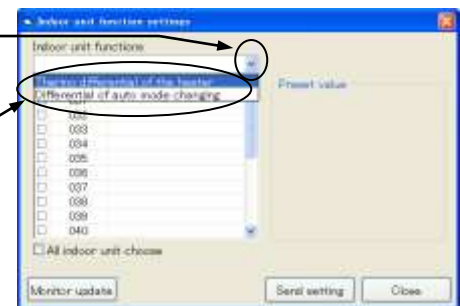

- (2) Click the **[Monitor update]** button. The current data for the selected function will be collected from all indoor units, and the results will appear in the **[Current value]** field.

• Values that may appear in the **[Current value]** field (Example of displayed value.)

Displayed value		Description
Thermo differential of the heater	1.0~5.0	Current preset value
Differential of auto mode changing	0.9*~5.0	
Default		Default value
Not available		The selected function is not supported.

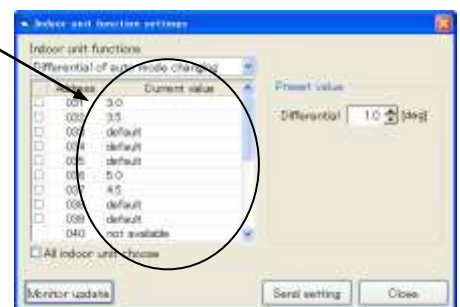

* Some models are unsupported to set 0.9 degrees.

3.16.3 Setting/Changing the values

- (1) Select the function whose preset value is to be set/changed from the list of **[Indoor unit functions]**. (Refer to **[3.16.2 (1)]**)
 - a) Click **[▼]** next to **[Indoor unit functions]**.
 - b) Select the desired function from the list of functions.
 - c) The selected function will appear under **[Indoor unit functions]**.

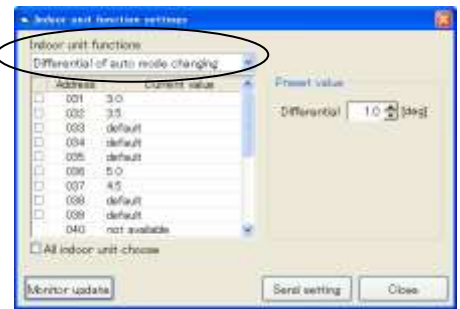

- (2) **Click the check box next to the indoor units** whose preset values are to be set/changed (multiple selection allowed).

When the check box next to **[All indoor unit choose]** is clicked, all indoor units are selected.

- (3) Enter the values in the **[Differential]** field.
 - a) Click **[▲]** **[▼]** next to the preset value to increase or decrease the value.
 - Clicking **[▲]** increases the value in 0.1 increments.
 - Clicking **[▼]** decreases the value in 0.1 increments.
 - The range of values available depends on the function.

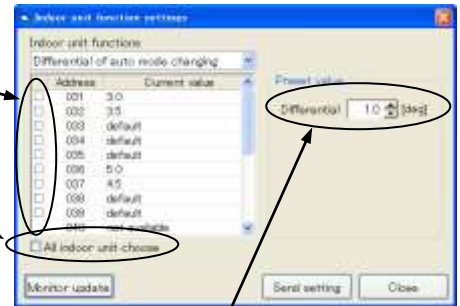

- (4) Click the **[Send setting]** button.
 - a) The changes made to the selected functions for the selected indoor unit(s) are reflected.
 - b) The current data for the selected function will be collected from all indoor units, and the results will appear in the **[Current value]** field. (Refer to **[3.16.2 (2)]**)

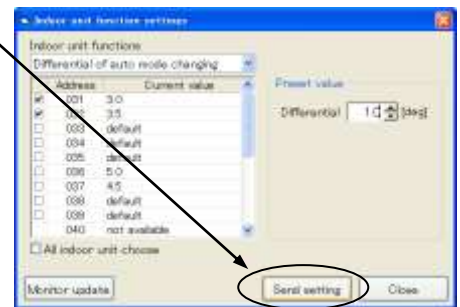

3.16.4 Exiting the function

- (1) Exiting sequence
 - a) Click the **[Close]** button to close the **[Indoor unit function settings]** screen to go back to the **[On-Line Main]** screen.

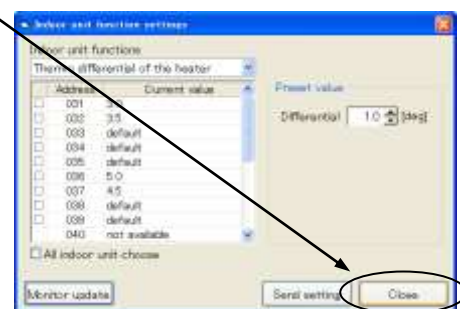

3.17 Compressor operating data monitor

*** Features**

- Cumulative compressor operation time and the total number of startup times of the outdoor units and chillers can be monitored.
- Cumulative pump operation time and the total number of startup times of the chillers can be monitored.
- When replacing the circuit board on the outdoor unit or the chiller, cumulative compressor operation time and the total number of startup times data can be acquired and stored, and then written to the new circuit board after replacement.

3.17.1 Start-up

(1) Start-up sequence

- a) Outdoor units: Click **[Option]** of the menubar on the **[On-Line Main]** screen, and click **[Compressor operating data monitor]** → **[Online Monitor]** of the submenu.
 Chillers: Click **[Monitoring operation data of compressor for chiller]**.

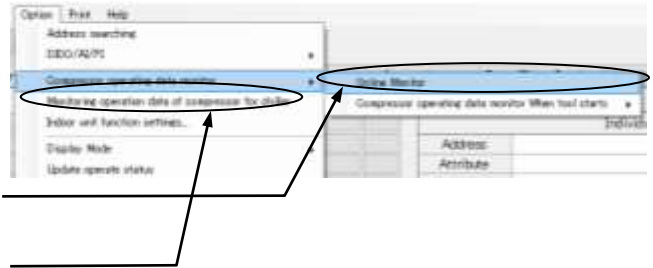

- b) The **[Compressor operating data monitor comment input]** screen is displayed.
 Input the comment on the monitored data.



- c) When **[OK]** button clicked, it start the monitoring.

- d) When the monitor is completed, the monitor result is saved, and the list of the data monitored to **[Compressor operating data monitor list]** screen is displayed.

PC Date and Time	Comment
6/27/2018 08:14:45	Data1
6/27/2018 10:29:40	
6/27/2018 09:49:51	
6/28/2018 10:50:44	
6/28/2018 11:11:20	
6/27/2018 08:14:45	
6/27/2018 15:42:00	
6/27/2018 14:57:39	
6/27/2018 13:26:06	
6/27/2018 10:02:30	
6/8/2018 16:11:29	

3.17.2 Compressor operating data monitor

- (1) When the line of data that wants to confirm the monitor result is clicked from [Compressor operating data monitor list] screen, and [Display] button is clicked, the monitor result is displayed on [Compressor operating data monitor] screen.

When the line of data clicked from the list screen, and [Delete] button is clicked, the selected data is deleted.

When [Exit] button is clicked, it returns to [On-Line Main] screen.

- (2) To close [Compressor operating data monitor] screen, [Close] button is clicked. It returns to [Compressor operating data monitor list] screen.

NOTE:
When the units with only one or two compressor, the compressor operating time and startup monitor that doesn't exist is displayed as "-".

- (3) In the case of some chiller, in addition to the compressor data, the pump data are also displayed.

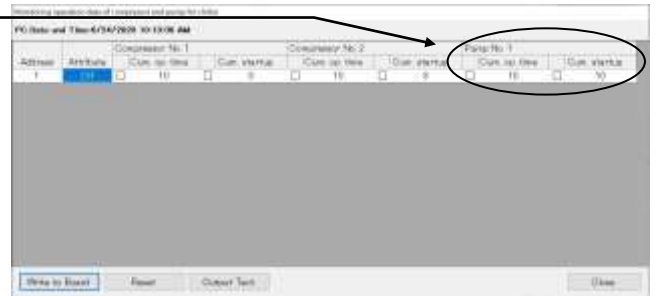
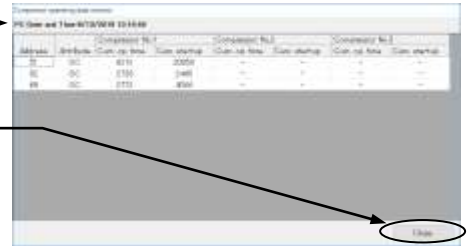
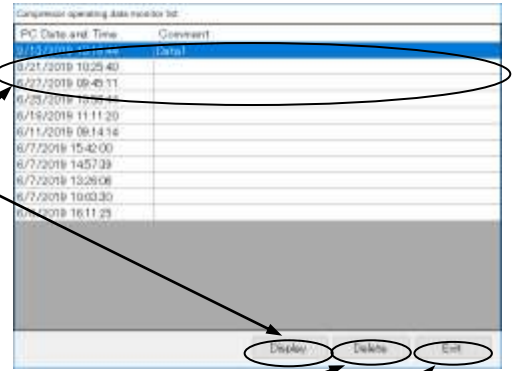

3.17.3 Importing the compressor operation data to the control board

- When replacing the control board on the unit, the compressor operation data need to be restored as follows.

- (1) Before replacing the control board, acquire and save the operation data according to "3.17.2 Compressor operating data monitor."
- (2) On the [**Compressor operating data monitor**] screen, select the unit to which you want to import the operation data.

- (3) Clicking the [**Write to Board**] button will show a message "Address(**) will be written to the board. Do you want to continue?"

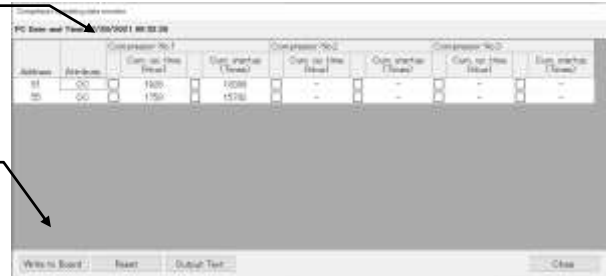

Clicking [**Yes (Y)**] will start writing the operation data that were acquired in step (1) above.

Clicking [**No (N)**] will display the [**Compressor operating data monitor**] screen without writing the operation data.

3.17.4 Resetting the compressor operation data

- (1) Clicking the [**Reset**] button will show a message "Address(**) will be reset. Do you want to continue?"

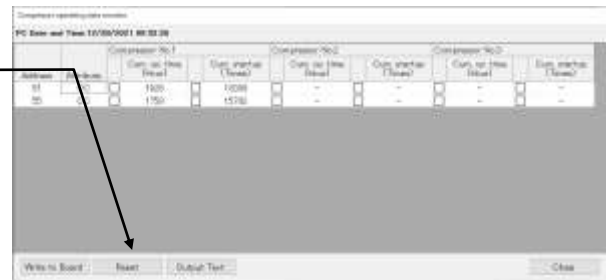

Clicking [**Yes (Y)**] will reset the operation data. The cumulative compressor operation time and the total number of startup times will be reset to zero.

Clicking [**No (N)**] will display the [**Compressor operating data monitor**] screen without resetting the operation data.

3.17.5 Automatic compressor operating data monitor when Tooltart

- (1) Click **[Option]** of the menubar on the **[On-Line Main]** screen, and click **[Compressor operating data monitor]→[Compressor operating data monitor When Tooltarts]** of the submenu. And then click **[Active]**.

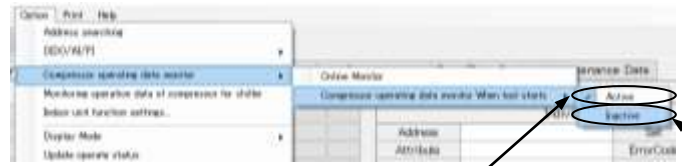

When the Maintenance Tool (at On-Line mode) starts, the compressor operating time is monitored and saved automatically.

[Compressor operating data monitor When tool starts] will be kept active once it becomes active.

The data automatically saved when the Tooltarts can be referred to by **[3.17.2 Compressor operating data monitor]** and **[4.6.1 Compressor operating data monitor(Off-Line Analyzing)]**.

To Make it inactive, click **[Inactive]** of the submenu.

NOTE:

- This function is only for use with the outdoor units.
Chillers are not supported.
- The comment doesn't attach to the data automatically monitored when the Tooltarts.

NOTE:

When the compressor operating data monitor when the Tooltarts is inactive, the uptime of the Maintenance Tool is shortened.

3.18 Initial Settings and Monitoring AHC ADAPTER

3.18.1 About AHC

Advanced HVAC CONTROLLER (hereafter referred to as AHC) comprises of MITSUBISHI ELECTRIC's AHC ADAPTER (PAC-IF01AHC-J) and α 2 SIMPLE APPLICATION CONTROLLER* (hereafter referred to as ALPHA2).

* α 2 SIMPLE APPLICATION CONTROLLER is one of the Programming Logic Controllers that are manufactured by MITSUBISHI ELECTRIC CORPORATION.

AHC allows for the connection of M-NET to other systems, which was not possible with the use of ALPHA2 alone. AHC provides the following functions.

1. Controls external devices using the sensor data of the air conditioning units connected to M-NET.
2. Interlocks the operation of air conditioning units and external devices that are connected to ALPHA2.
3. Controls air conditioning units that are connected to M-NET.
4. Allows for the combined use of the items 1-3 above.
5. Monitors the input/output status of ALPHA2 via a remote controller or a centralized controller.

This manual includes descriptions of the how to initial settings of AHC and the AHC Status Monitor by Maintenance Tool. Refer to the AHC Technical Manual for more details for AHC.

3.18.2 Initial Settings of AHC

Open the AHC Initializing Setting screen

- (1) From the [Option] menu bar, select [AHC] > [AHC Initialize Setting].

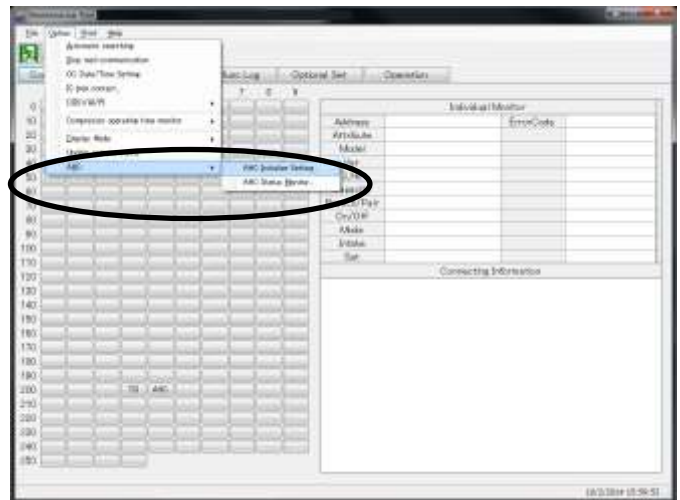

- (2) The [Address Change] screen appears. Enter the M-NET address of the AHC ADAPTER to be initialized and then click the [OK]. Refer to the AHC Installation Manual for how to set the address for the AHC ADAPTER.



- (3) The progress bar appears. This process may take a couple of minutes depending on the number of setting items.

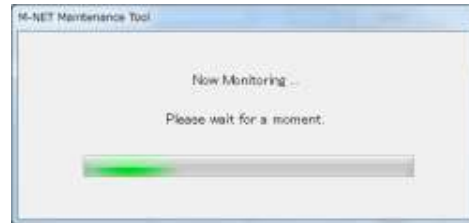

- (4) The [AHC Initialize Setting] screen opens.

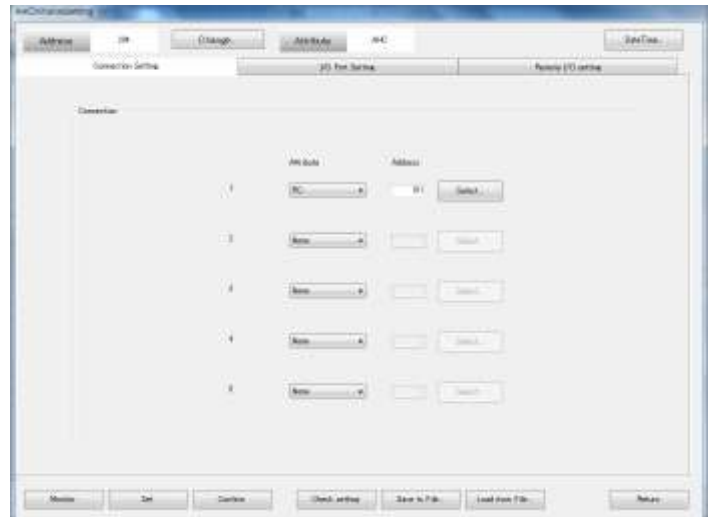

The screen configuration is as follows.

1. Address Display Area

2. Initial Settings Input Area

3. Time Setting and Monitoring

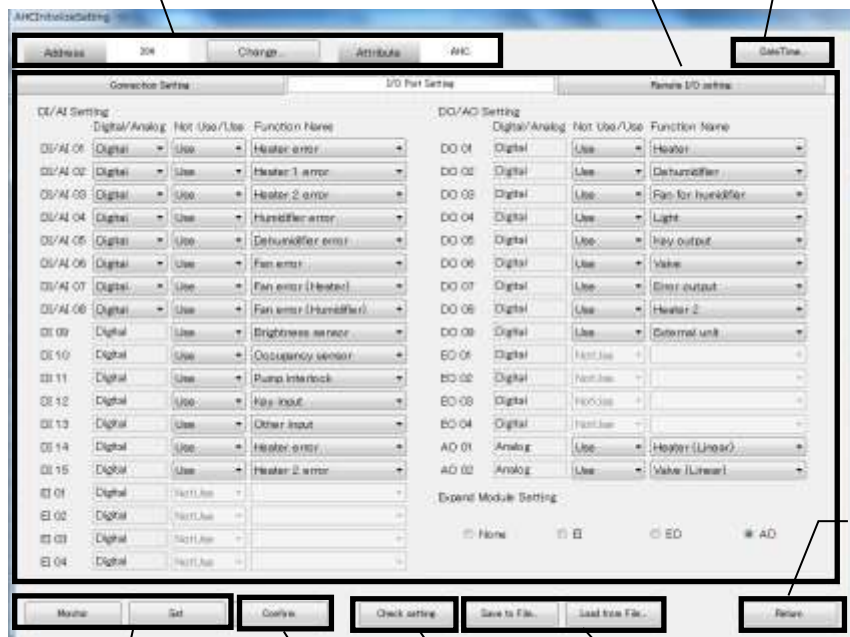

4. AHC Initial Settings and Monitoring

7. Saving and Loading Data

6. Check setting

5. Confirm

8. Return

1. Address Display Area
Displays the M-NET address for AHC. Press the [**Change**] button and specify the M-NET address to configure the initial settings of another AHC and monitor. Refer to [3.11.1.1 Malfunction Log 3.11.1.1.1 (5)]
2. Initial Settings Input Area
Allows you to edit the initial setting items of AHC. The items that can be set vary depending on the selected tab. Refer to [3.18.3 Editing the Connection Information through 3.18.7 Editing the Remote I/O setting]
3. Time Setting and Monitoring
The [**AHC Date/Time Setting**] screen appears. Refer to [3.18.8 Time Setting and Monitoring]
4. AHC Initial Settings and Monitoring
Press the [**Set**] button to set the item that was edited in “2. Initial Settings Input Area” for AHC. Press the [**Monitor**] button to monitor the setting item and update the display from AHC. Refer to [3.18.9 Settings and 3.18.10 Confirmation of Settings]
5. Confirm
Displays the [**Status Check**] screen. The settings on the Remote I/O of ALPHA2 and AHC ADAPTER can be checked on the [**Status Check**] screen. Refer to [3.18.11 Confirm]
6. Check setting
The [**Check setting data**] screen appears. The [**Check setting data**] screen can be used to check details of settings configured for the AHC and to print setting items. Refer to [3.18.12 Check Setting]
7. Saving and Loading Data
Press the [**Save to File**] button to save the item that was edited in “2. Initial Settings Input Area.” Press the [**Load from File**] button to apply the settings saved in the file to the “2. Initial Settings Input Area.” Refer to [3.18.13 Saving the Setting File and 3.18.14 Loading the Setting File]
8. Return
Use the [**Return**] button to close the [**AHC Initialize Setting**] screen and return to the [**Main**] screen.

3.18.3 Editing the Connection Information

Assign the controllers (centralized controller and remote controller) to AHC. The status of external equipment connected to AHC can be monitored from the assigned controllers.

Furthermore, if an error occurs with AHC, the error status can be displayed on the controllers.

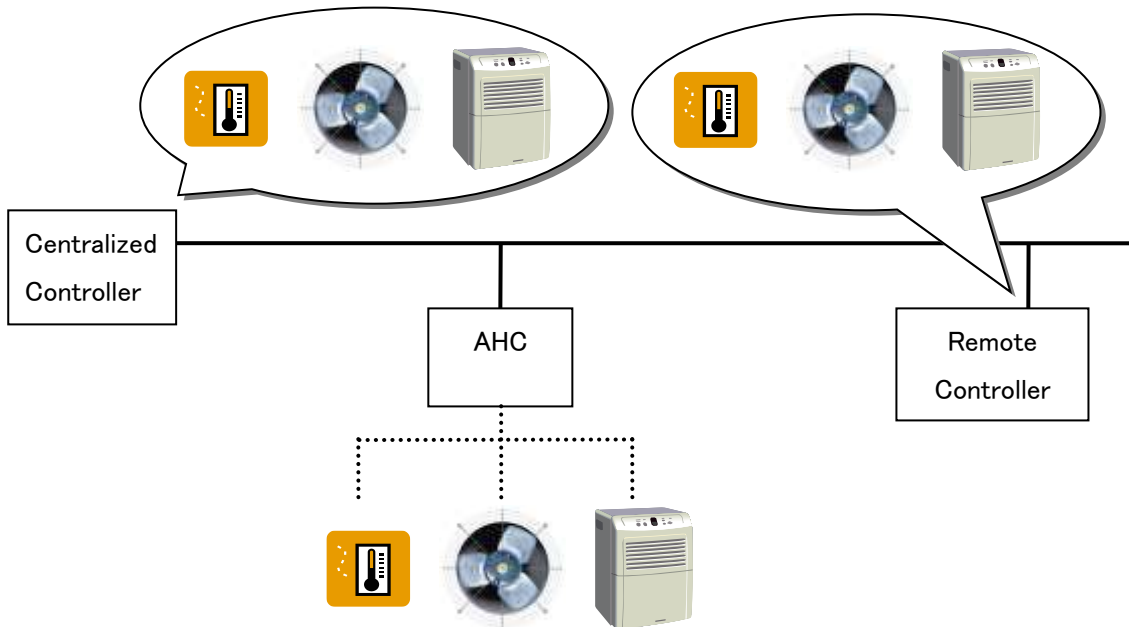

- (1) Select the [Connection Setting] tab and enter the M-NET address for the remote controller in the M-NET address input box. Enter the M-NET address of the Remote Controller in the M-NET address input box, or alternatively use the [Select] button to select the M-NET address to be set.

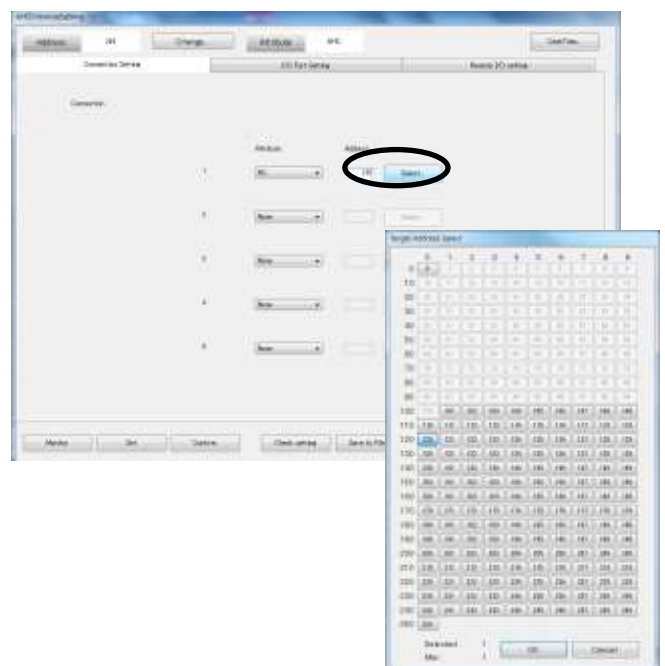

NOTE:

- Only the M-NET address for the remote controller can be set in Maintenance Tool. The M-NET address of the centralized controller set as AHC can be monitored from Maintenance Tool but cannot be changed and set by Maintenance Tool. Assign the centralized controller to AHC from the centralized controller.

(*) Refer to the centralized controller manual

NOTE:

- Setting item input boxes that are still blank will display with a bold red frame to highlight that they are blank.

Enter the M-NET address for the Remote Controller.



NOTE:

- The controller attribute is shown in [Attribute]. **[TR]** displays for the Main centralized controller, **[RC]** for the Remote Controller, and **[SC]** for the Sub centralized controller.

3.18.4 Editing the I/O Port Setting

Set the input and output function of ALPHA2.

- (1) Select the [I/O Port Setting] tab.

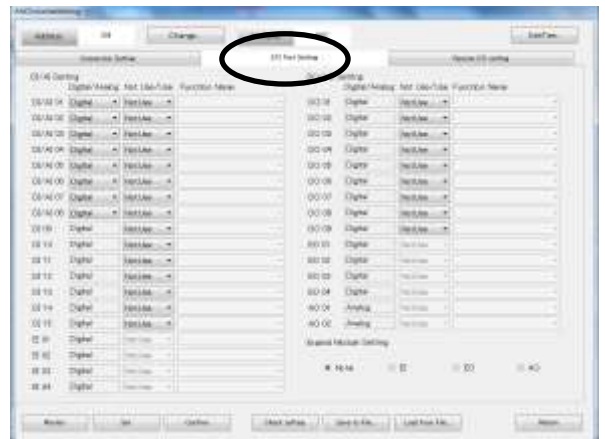

- (2) Select the expansion module. The ports that can be set are converted in accordance with the expansion module type.

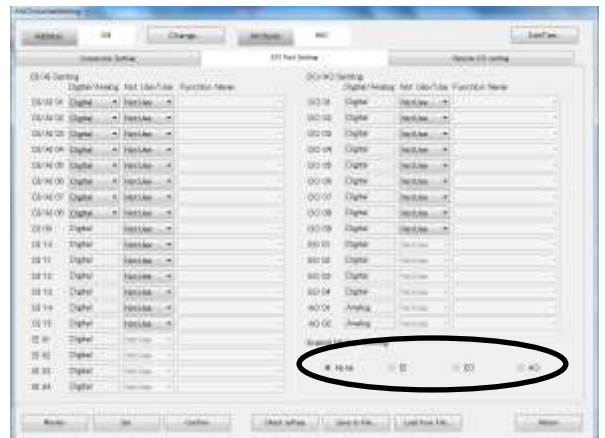

- (3) Select the input and output information

a) Digital/Analog

Set whether the input and output ports are used for analog or digital inputs and outputs. The function names that can be selected vary depending on whether Analog or Digital is selected.

b) Not Use/Use

Set whether to use or not use the input and output ports.

c) Function name

Set the function for which to use the input and output ports.

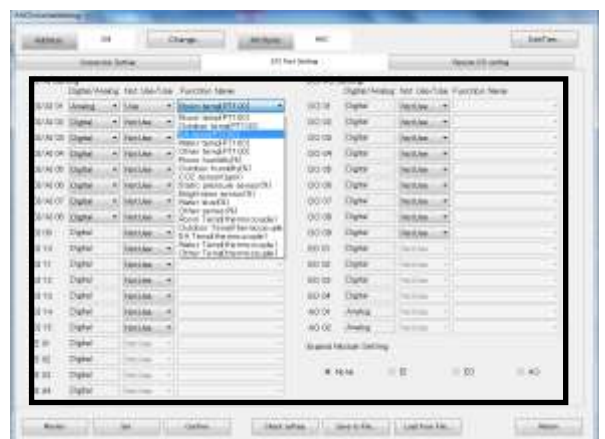

3.18.5 Editing the Remote I/O setting

Set the Remote I/O settings. Once the Remote I/O settings are configured, the AHC will start the below operations.

- Monitoring of input data (sensor data and operating status) for the unit connected to M-NET
- Output from the unit connected to M-NET

Note that the steps for navigating the [**Remote I/O setting**] tab vary according to the DipSW103-3 and version of AHC ADAPTER in use.

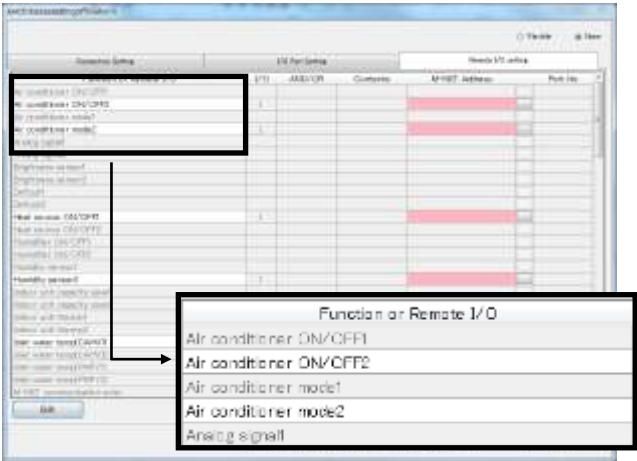
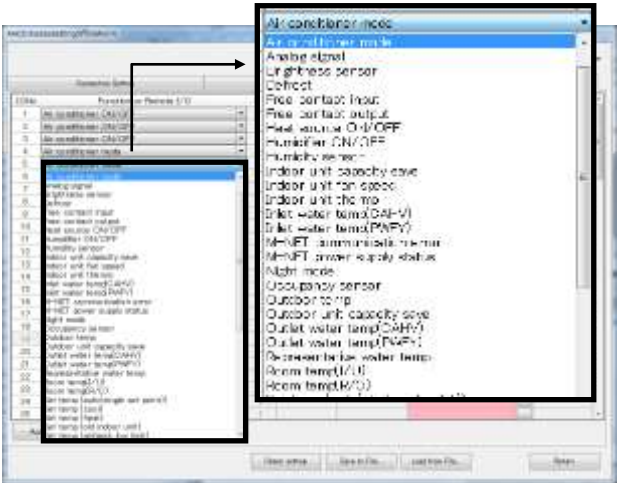
AHC ADAPTER Ver	DipSW 103-3	[Remote I/O setting] screen
<p>Versions prior to Ver. 2.00</p> <p>Ver. 2.00 or later</p>	<p>ON</p> <p>OFF</p> <p>ON</p>	<p>Users select whether to enable or disable each function available for use. The functions assigned to each Remote I/O setting for monitoring and operation are all locked.</p> 
<p>Ver. 2.00 or later</p>	<p>OFF</p>	<p>Users can select functions assigned to each Remote I/O setting and the number of target groups as desired. Each function can be assigned to a maximum of 50 groups.</p> 

3.18.6 Editing the Remote I/O setting

(For an AHC ADAPTER Ver. 2.00 or Later AND when DipSW103-3 is set to OFF)

(1) Select the [Remote I/O setting] tab.

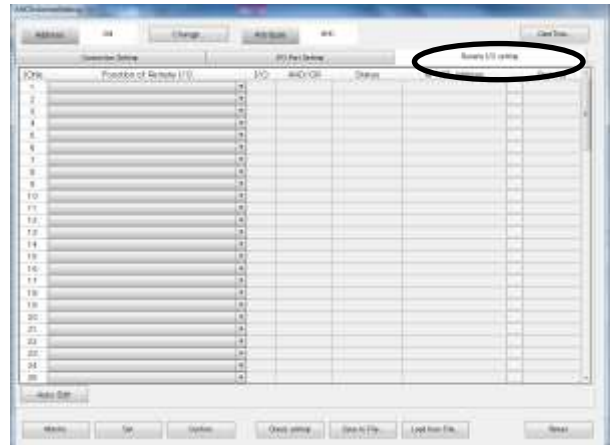

(2) Click the drop-down list in the [Function of Remote I/O] box to display a list of function that can be assigned to the remote I/O.

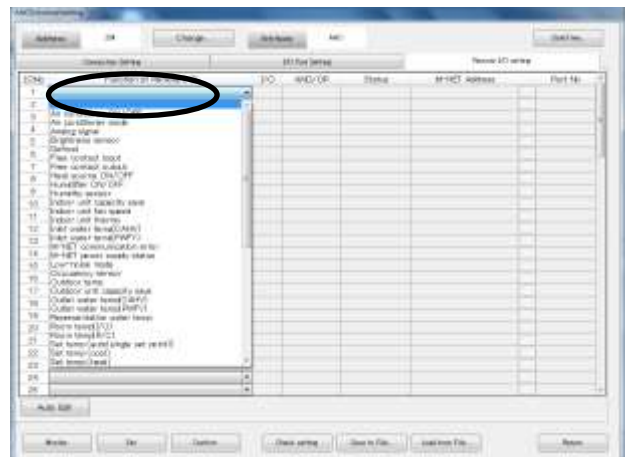

(3) Select the function to be assigned to the remote I/O.

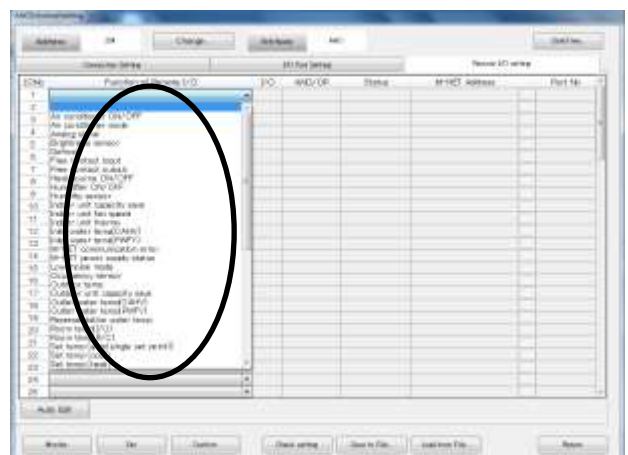

NOTE:

- Although any desired Remote I/O function can be assigned to each [I/O No] for most I/O No., the only Remote I/O function that can be assigned to I/O No. 19 is Set humidity.
- No functions can be assigned to the I/O with the following numbers: 65, 96, 97, 98, 99, 100.

- (4) Click the **[Auto Edit]** button to open the **[Number of I/O setting]** screen. Use this function to set a number of Remote I/O settings all at once.

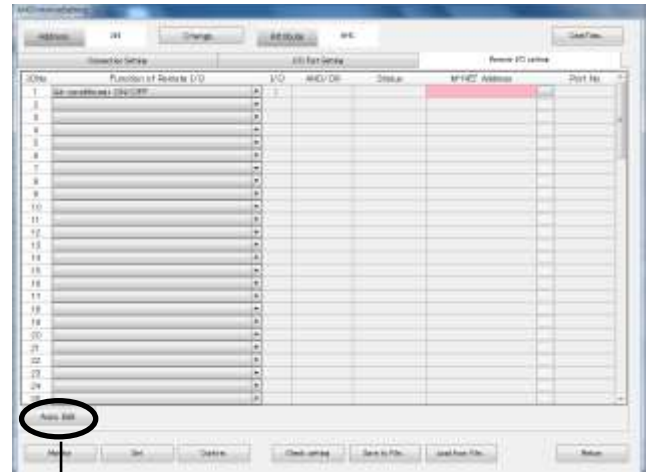

- (5) Enter the number of Remote I/O settings to set in the **[Count]** box. Any number that lies within the range shown in the **[Range]** box can be used. The maximum number of Remote I/O settings that can be set is listed at the bottom of the screen. The number of Remote I/O settings to be set cannot exceed this maximum number.

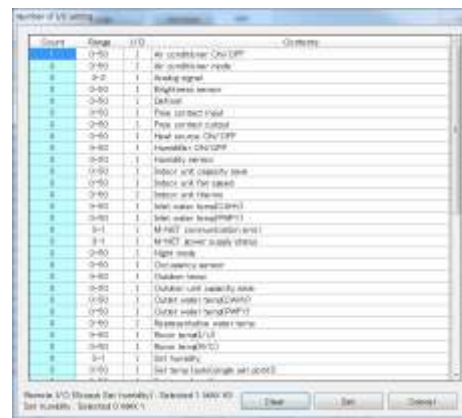



Click the **[Set]** button to reflect the changes made to the settings shown on the **[Number of I/O setting]** screen in the **[Remote I/O setting]** tab.

Click the **[Clear]** button to reset all the values in the **[Count]** column to zero. Then, click the **[Set]** button to clear all the settings on the **[Remote I/O setting]** tab.

Click the **[Cancel]** button to close the **[Number of I/O setting]** screen without reflecting the changes made to the settings shown on the **[Number of I/O setting]** screen.

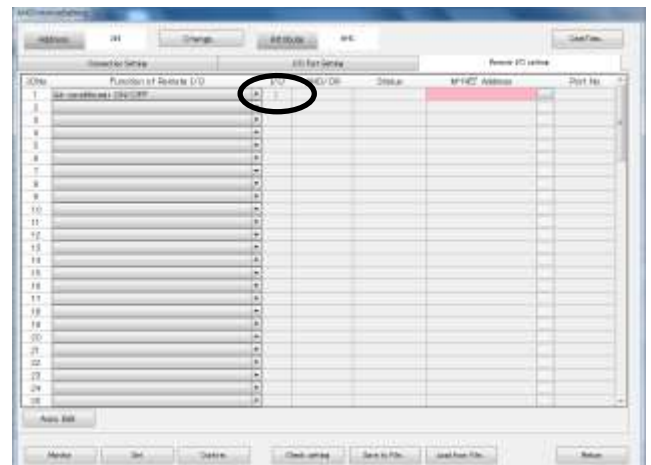
- (6) Once the **[Function of Remote I/O]** is configured, the input type for the Remote I/O setting set in the **[I/O]** box appears on the screen. [I] is an input. The sensor data for the unit connected to M-NET and the operating status are monitored periodically by the AHC. [O] is an output. Operation of the unit connected to M-NET is controlled by the AHC control logic.



- (7) Once a function is assigned to the remote I/O, the background color of the **[M-NET Address]** box changes to red. Set the M-NET address for the target of the operation and monitor in the **[M-NET Address]** box. To set the M-NET address, either enter the M-NET address directly into the input box, or push the  button on the side of the **[M-NET Address]** box and then select the M-NET address of the relevant unit from the **[Target Address Select]** screen that appears. The **[M-NET Address]** column will be grayed out when no address settings are required.

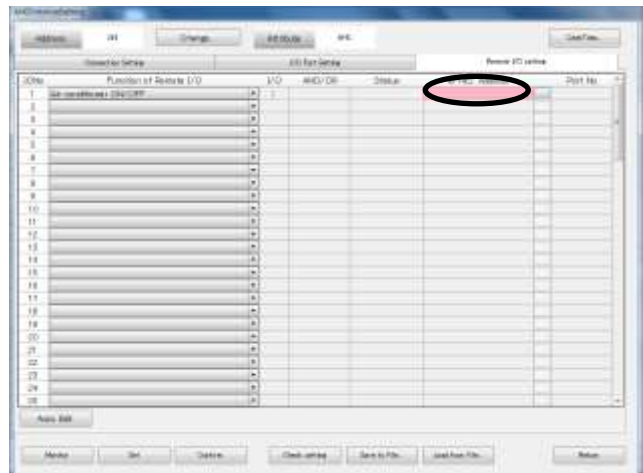

The number of selectable M-NET addresses and the range of M-NET addresses differ according to the selected input data. The maximum number of selectable M-NET addresses is displayed at the bottom of the **[Target Address Select]** screen.



For some selected input data, the message “Do you want to receive directly from the operation of the RC?” may be displayed when switching to the **[Target Address Screen]**.

If **[Yes]** is selected, the input data is acquired from the remote controller assigned in 3.18.3 Editing the Connection Setting.

If **[No]** is selected, the **[Target Address screen]** appears. Click the M-NET addresses to acquire the input data for and click the **[OK]** button.



- (8) Set the aggregation condition.
Set the aggregation condition only when selecting multiple M-NET addresses.

a) AND/OR

Select the aggregation condition (AND: match for all units or OR: match for at least one unit) to output the acquired data to ALPHA2 when AHC ADAPTER acquires data from multiple units.

b) Status

Select the condition for AHC ADAPTER to output the acquired data to ALPHA2.

Use the contents in combination with the AND and OR conditions.

Select the acquired value for AHC ADAPTER to send to ALPHA2.

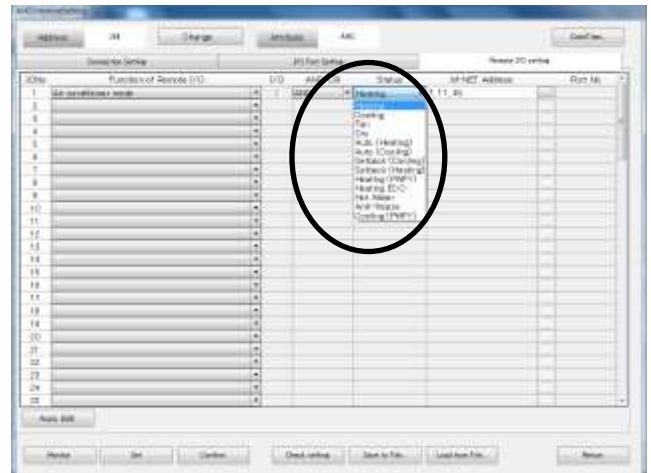

- (9) Select the port.

Note that the Port No. will need to be set for some functions. Set the input and output terminals.

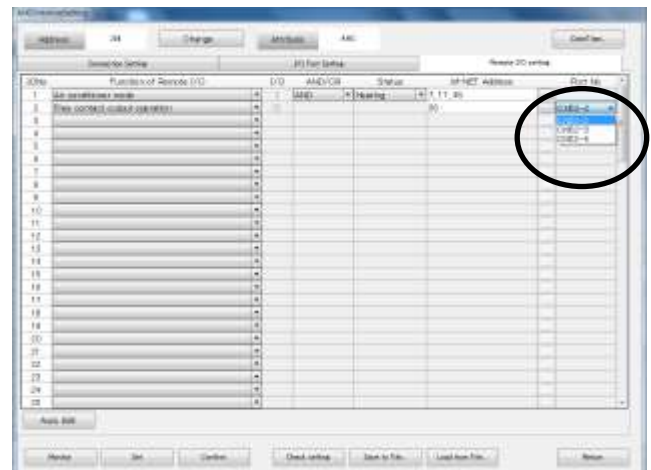

NOTE:

- An error message will appear if two or more I/O numbers have identical settings. If the message appears, check the settings.

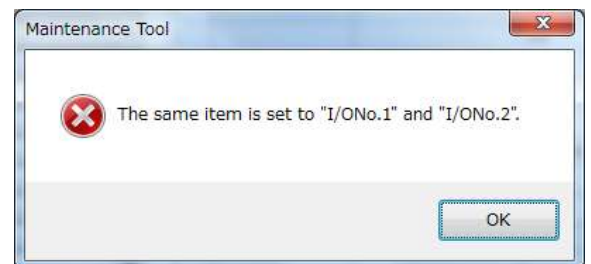

3.18.7 Editing the Remote I/O setting

(Applicable to AHC ADAPTERS version 2.00 and later AND when DipSW103-3 is set to a setting other than OFF)

The method for configuring the [Function of Remote I/O] settings differs for the DipSW103-3 and version of AHC ADAPTER .

NOTE:

- All settings other than the [Function of Remote I/O] settings can be configured in the same way as described in [3.16.6 Editing the Remote I/O setting (Applicable to AHC ADAPTERs Ver. 2.00 and Later AND when DipSW103-3 is set to OFF)]

- (1) Select the [Remote I/O setting] tab and then click the [Edit] button.

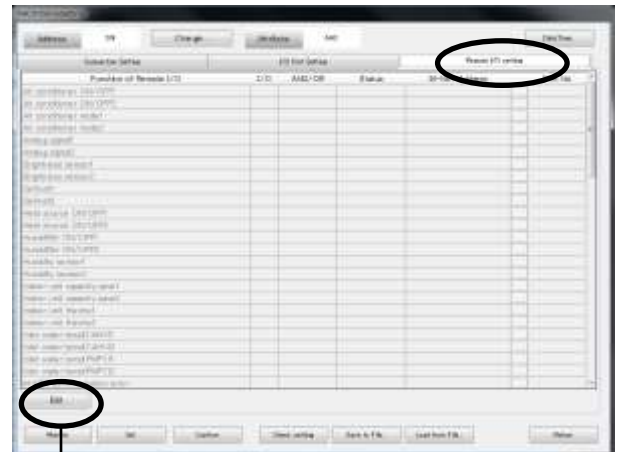

- (2) The [I/O Setting List] screen appears. Check off the checkbox of the desired setting item to enable the setting.

Click the [Set] button to reflect the changes made to the settings shown on the [I/O Setting List] screen in the [Remote I/O setting] tab.

Click the [Clear] button to uncheck all the checkboxes in the [Check] column. Then, click the [Set] button to clear all the settings on the [Remote I/O setting] tab.

Click the [Cancel] button to close the [I/O Setting List] screen without reflecting the changes made to the settings shown on the [I/O Setting List] screen.

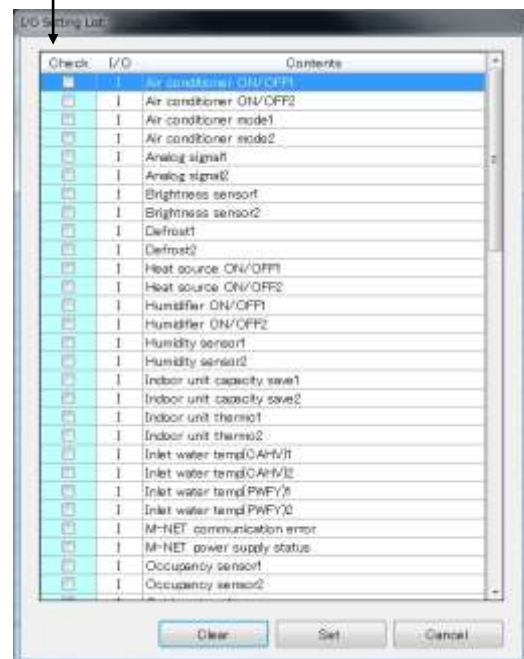

3.18.8 Time Setting and Monitoring

(1) Click on [**Datetime**] button.

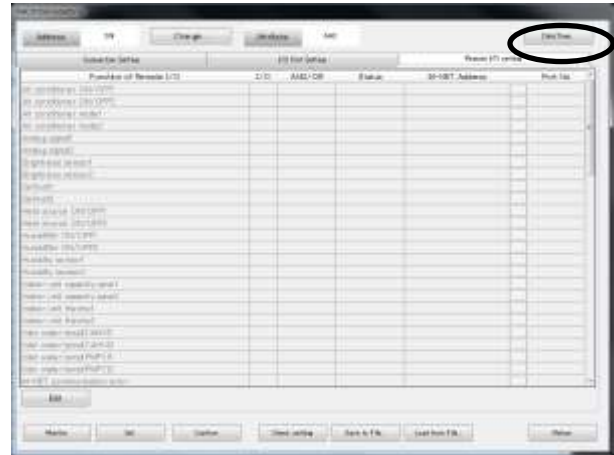

(2) The [**AHC Date/Time Setting**] screen opens and the present time of PC is displayed.

A click of [**Set**] button sets the time currently displayed to a AHC. The time to set up can also be changed on a screen. Cursor is united with a change point and a numerical value is inputted.

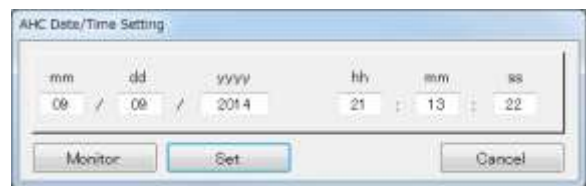

Click on [**Monitor**] button to acquire the current setting Date/Time and display the results in the [**AHC Date/Time Setting**] screen.

Click on [**Cancel**] button to end the [**AHC Date/Time Setting**] screen.

3.18.9 Settings

Apply the edited initial setting data to AHC.

- (1) Click on **[Set]** button.

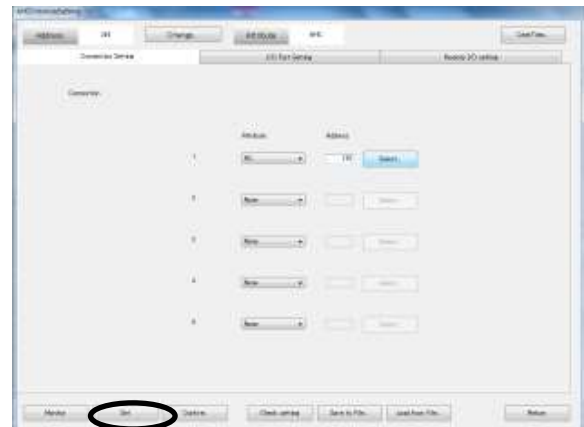

- (2) A confirmation screen appears. Click the **[Yes]** button.

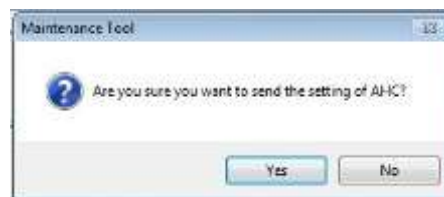

- (3) The progress bar appears. This process may take a couple of minutes depending on the number of setting items.



- (4) Configuration of the initial settings is complete.



An error message appears if monitoring fails. Below is a list of possible causes of problems. For details, refer to the section on Troubleshooting.

- The initial settings are duplicated from Centralized Controller.
- There are problems with M-NET communications between devices.

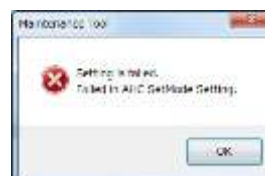

3.18.10 Confirmation of Settings

Check the settings set for the AHC.

- (1) Click the **[Monitor]** button.

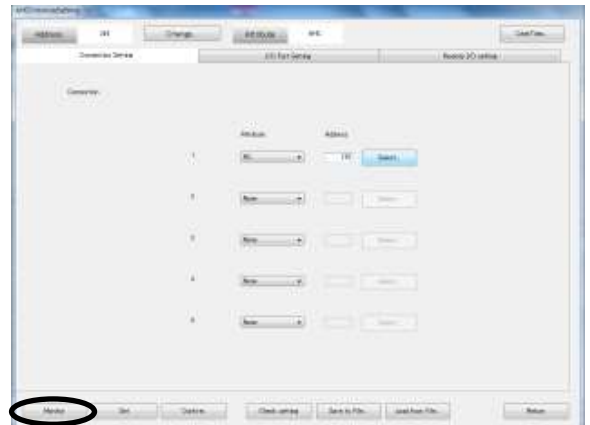

- (2) A confirmation screen appears. Click the **[Yes]** button.



- (3) The progress bar appears. This process may take a couple of minutes depending on the number of setting items.



- (4) Settings configured for the AHCare reflected when monitoring finishes. Check to make sure that the setting details shown match those entered
If they do not match, reconfigure the settings that need to be changed.

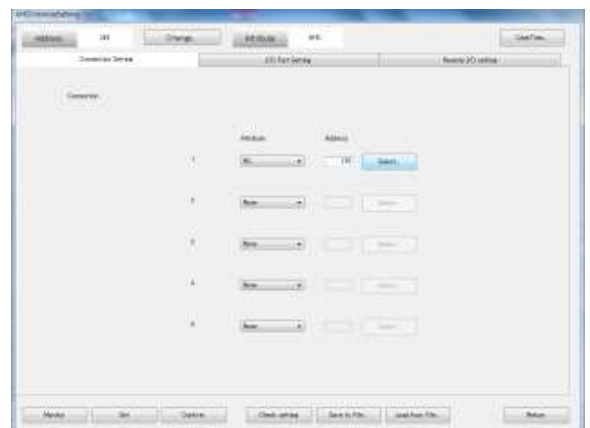

An error message appears if monitoring fails. Below is a list of possible causes of problems. For details, refer to the section on Troubleshooting.

- The initial settings are duplicated from Centralized Controller.
- There are problems with M-NET communications between devices.

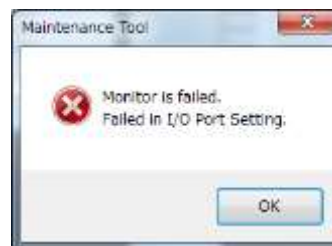

3.18.11 Confirm

Clicking the **[Confirm]** button will display the **[Status Check]** screen. Assigning the air conditioner monitoring/operating function to the Remote I/O of the AHC will require the programming of ALPHA2 and setting of the initial settings of AHC ADAPTER via the M-NET (on the Remote I/O setting tab). On the **[Status Check]** screen, if a function is assigned to the I/O No. of ALPHA2 and the AHC ADAPTER can be checked.

(1) Click the **[Confirm]** button.

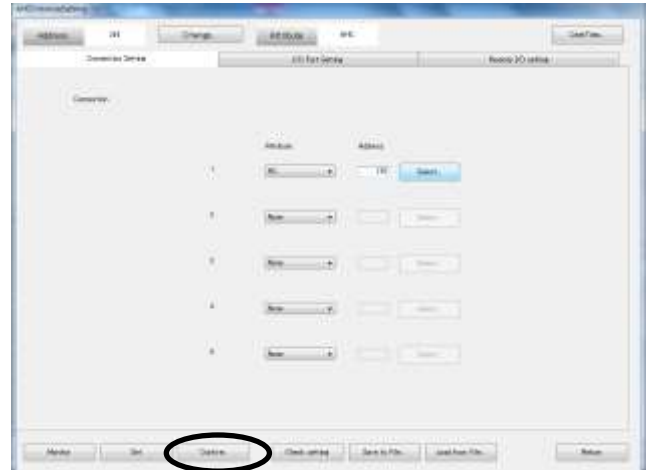

(2) The progress bar appears. This process may take a couple of minutes depending on the number of setting items. To cancel the monitoring process, click the Cancel button.



(3) The **[Status Check]** screen appears. The availability status list of ALPHA2 and the AHC ADAPTER will appear. The status of each I/O No. will appear either as **[Available]** or **[NotAvailable]**. If the availability status settings of ALPHA2 and AHC ADAPTER do not match, the cell will be highlighted in red. Check the settings on ALPHA2 and the AHC ADAPTER. Click the **[Close]** button to close the **[Status Check]** screen.

NOTE:

- The settings for ALPHA2 and the AHC ADAPTER must match for the function assigned to the Remote I/O to function properly.

IoNo	α 2	AHC ADAPTER
1	Available	NotAvailable
2	Available	Available
3	NotAvailable	Available
4	NotAvailable	NotAvailable
5	Available	Available
6	Available	NotAvailable
7	Available	Available
8	NotAvailable	Available
9	NotAvailable	NotAvailable
10	Available	Available
11	Available	NotAvailable
12	Available	Available
13	NotAvailable	Available
14	NotAvailable	NotAvailable
15	Available	Available
16	Available	NotAvailable
17	Available	Available
18	NotAvailable	Available
19	NotAvailable	NotAvailable

An error message appears if monitoring fails. Below is a list of possible causes of problems

- The version of the AHC ADAPTER software you are using does not support this function. This function is supported by versions 2.10 and later.

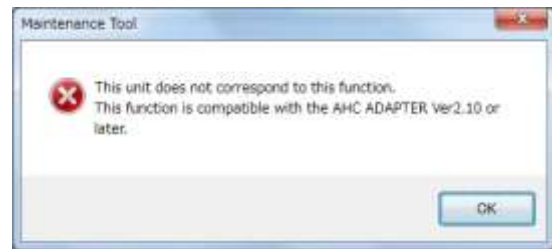

- A serial communication error was detected between ALPHA2 and the AHC ADAPTER. Check the serial cable connection between ALPHA2 and the AHC ADAPTER.



- The initial settings are duplicated from Centralized Controller.
- There are problems with M-NET communications between devices.



3.18.12 Check Setting

(1) Click the **[Check setting]** button.

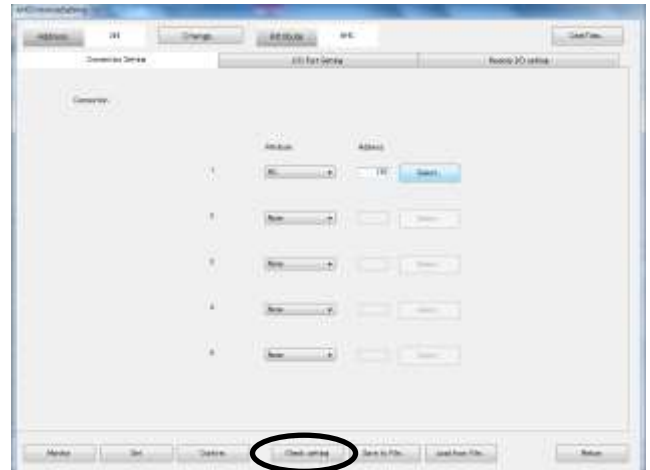

(2) The **[Check setting data]** screen appears. The **[Check setting data]** screen displays a list that can be used to check the settings entered for initial setting items. A bold red frame will display around setting boxes that are blank to highlight items that have not yet been configured. Click the **[Print]** button to enable a screenshot of the **[Check setting data]** screen to be printed out. Click the **[Close]** button to close the **[Check setting data]** screen.

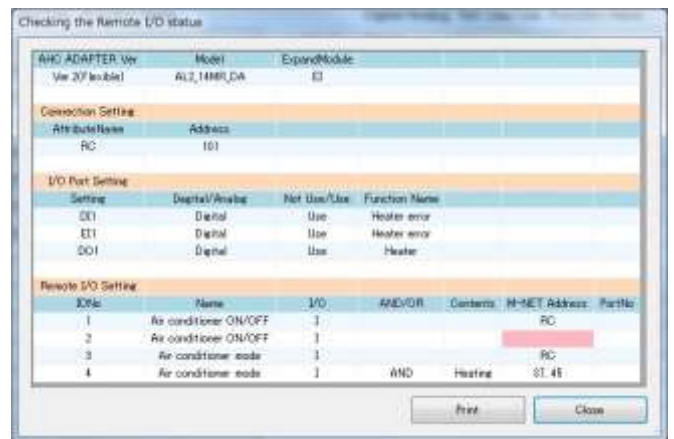

3.18.13 Saving the Setting File

Save the edited AHC initial setting data.

- (1) Click the **[Save to File]** button.

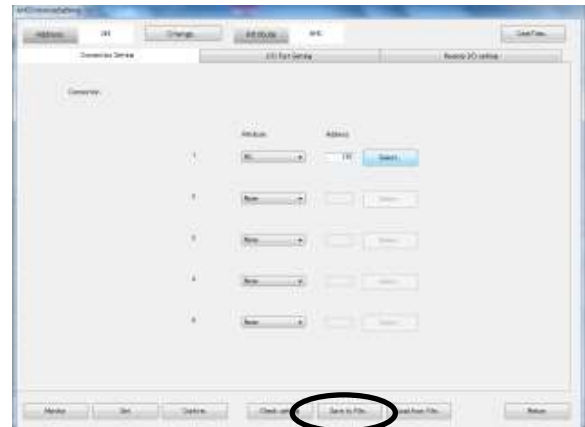

- (2) The save screen appears. Save the file to any folder.



- (3) A save successful screen appears. Click the **[OK]** button.



3.18.14 Loading the Setting File

Load the edited AHC initial setting data.

- (1) Click the **[Load from File]** button.

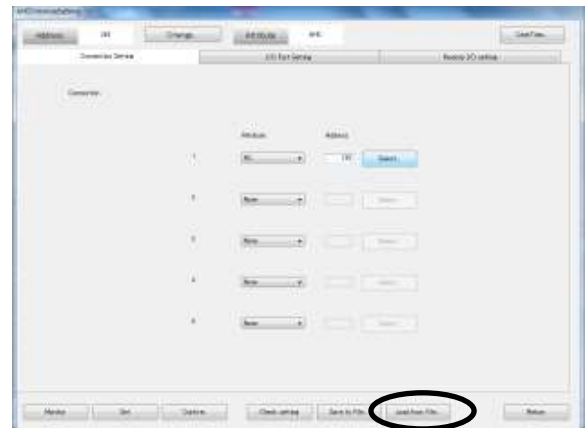

- (2) The file selection screen appears. Select the setting file.

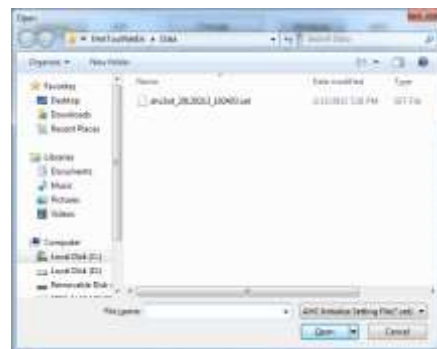

- (3) A table shows the setting items that will be changed when the setting file is loaded during online setting. If the setting items are acceptable, click the **[Yes]** button. The settings in the loaded setting file are applied.



- (4) A load successful screen appears. Click the **[OK]** button.



3.18.15 Monitoring of AHC

Open the AHC Status Monitor screen

- (1) From the **[Option]** menu bar, select **[AHC]** > **[AHC Status Monitor]**.

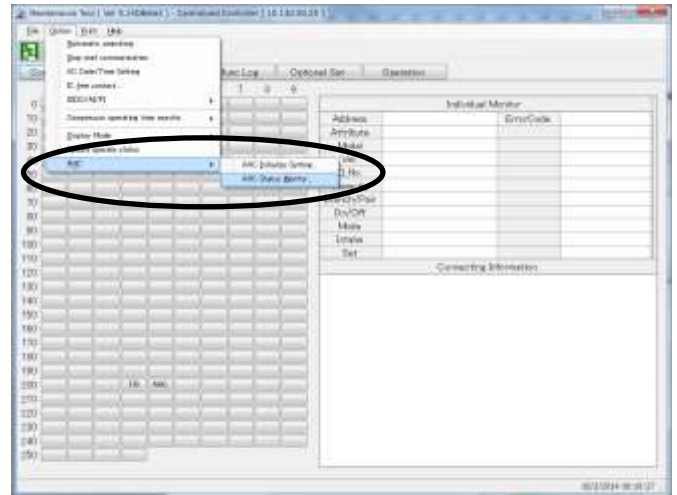

- (2) The **[Address Change]** screen appears. Enter the M-NET address of the AHC to be initialized and then click the **[OK]**.



- (3) The progress bar appears. This process may take a couple of minutes depending on the number of setting items.

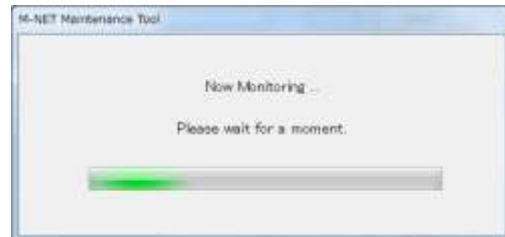

3.18.16 Monitoring of AHC

On the AHC List screen, the status of input and output ports of each Advanced HVAC CONTROLLER (AHC) can be monitored.

Click [Monitor/Operation] in the menu bar, and then click [AHC List] to access the AHC List screen.

The port names and their status of each AHC will appear.

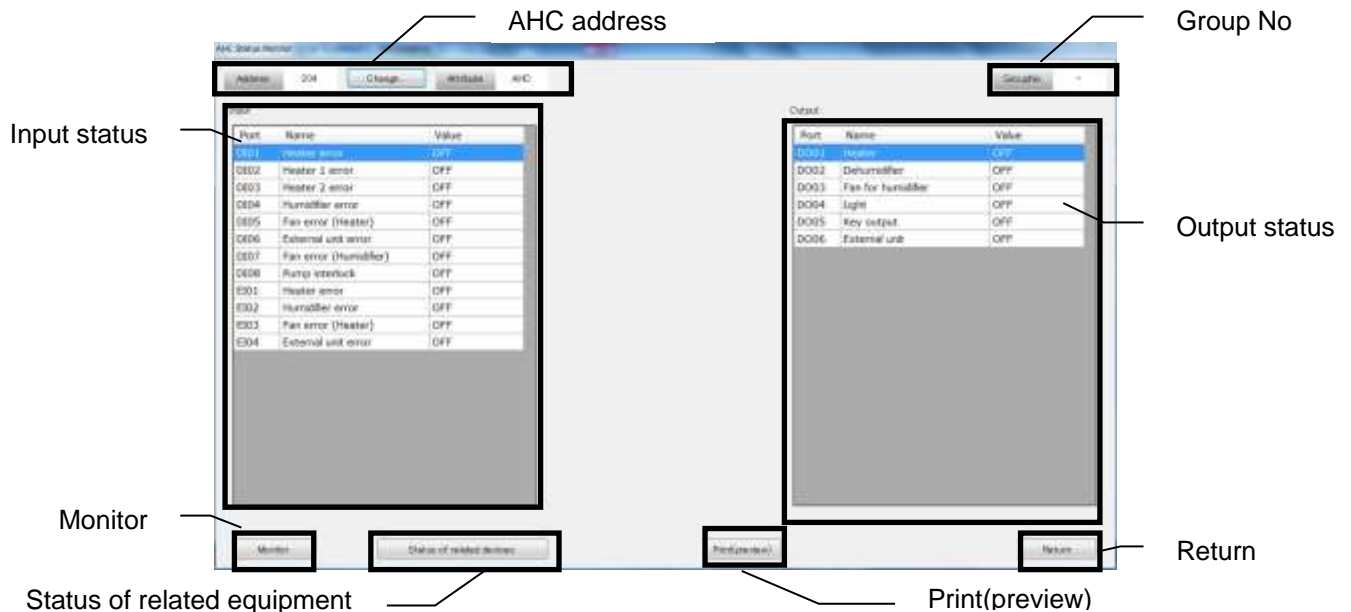

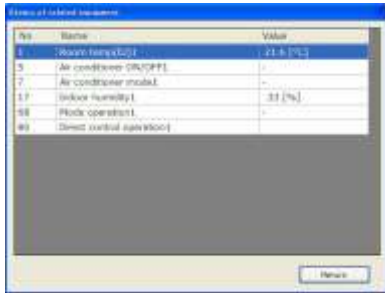
Item	Description
AHC address	The M-NET address of the connected AHC will appear.
Group No	The Group No. set for the AHC will appear.
Monitor	Click on [Monitor] button to acquire the current AHC Status and display the results in the [AHC Status Monitor] screen.
Input status	[Input port code * + Input port name + Input status] will appear. * DI1–DI15 (Digital input), EI1–EI4 (Extended digital input), AI1–AI8 (Analog input) Note: The status of the unused ports will not appear. Note: If a communication error occurs with AHC, no port information will appear.
Output status	[Output port code * + Output port name + Output status] will appear. * DO1–DO9 (Digital output), EO1–EO4 (Extended digital output), AO1–AO2 (Analog output) Note: The status of the unused ports will not appear. Note: If a communication error occurs with AHC, no port information will appear.
Status of related equipment	Click to display the status of the equipment that are used to control the equipments that are connected to the AHC. 
Print(preview)	A screenshot of the [AHC Status Monitor] screen can be printed out.
Return	Press the Return button to close the [AHC Status Monitor] screen and return to the [Main] screen.

3.19 Fixed value setting of compressor frequency

- This section describes how to lock the compressor to a fixed frequency.

- (1) With the dipswitch SW4 No. 857 on the outdoor unit turned on, click [Option] on the menu bar and then click [Fixed value setting of compressor frequency] on the sub menu to open the [Fixed value setting of compressor frequency] screen.

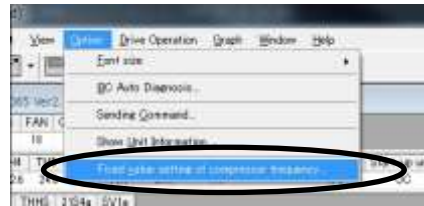

Note

- Compressor frequency can only be fixed while the compressor on the outdoor unit (OC) is in operation.
Compressor frequency cannot be fixed when one or more of the following conditions are met.
 - Only the auxiliary outdoor unit (OS) is operating for such reason as an emergency operation or a rotation operation.
 - Less than three minutes after the compressor on the OC started up.
 - The control mode other than the constant mode is being used.
- When a unit that does not support the fixed value setting of compressor frequency is selected, the following message, "This unit does not support the fixed value setting of compressor frequency." will appear, and the setting cannot be made.

- (2) The [Fixed value setting of compressor frequency] screen appears.

- A) Click the [Address Change] button and then select the M-NET address of the unit for which the compressor is to be locked to a fixed frequency.
- B) The current compressor fixed frequency [Fix/FixRelease] status display on the screen. To lock the compressor to a fixed frequency, first enter the value at which to lock the frequency and click the [Fix] button before clicking the [Send] button. To release the compressor from the fixed frequency, click the [FixRelease] button and then click the [Send] button.

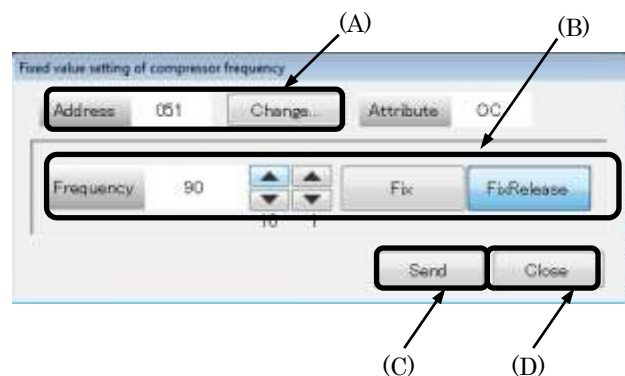

Note

- Note that the frequency set on the [Fixed value setting of compressor frequency] screen is the all temporary frequencies F (Foc + Fos).
- If the frequency of the outdoor unit is set to the frequency below the minimum frequency level, the unit will go into the Thermo-OFF state.

- C) Click the [**Send**] button to transmit the setting value.

Note

In order to prevent failure to trigger the setting status release, the system is designed to clear the settings shown on the screen automatically when the [**Operation status monitor**] screen is closed.

- D) Click the [**Close**] button to close the [**Fixed value setting of compressor frequency**] screen and return to the [**Operation status monitor**] screen.

3.20 Indoor unit LEV problem detection support

* Items Performed Here

- Problems with the LEV on indoor units are mainly divided into two types: Problems with the stepping motor and locking of the LEV. This function automatically identifies the indoor units with possible locking of the LEV.

Note

The LEV on indoor units consists of the stepping motor and the valve.

The LEV can either become locked-open or locked-close due to the following causes.

- Motor: Short-circuited coil
- Valve: Clogging by foreign substances or damage to the valve seat

3.20.1 Judgment conditions of the LEV diagnosis function and grouping of indoor units

This function automatically determines the operation mode (Cooling mode or Heating mode) to perform a diagnosis in, based on the indoor and outdoor temperatures.

Diagnosis of LEV locking is performed based on the values of TH2 (liquid pipe temperature) value and TH3 (gas pipe temperature) value.

Diagnosis is performed either by treating all indoor units in a given refrigerant system as one category or as two categories (A and B), depending on the number of remote controllers in a given system and the type of grouping made by the centralized controller.

(1) Diagnosis of all indoor units being treated as a single category

• When a given refrigerant system has only one group of indoor units.

Example. IC1 through IC6 are grouped into group 1 from the centralized controller

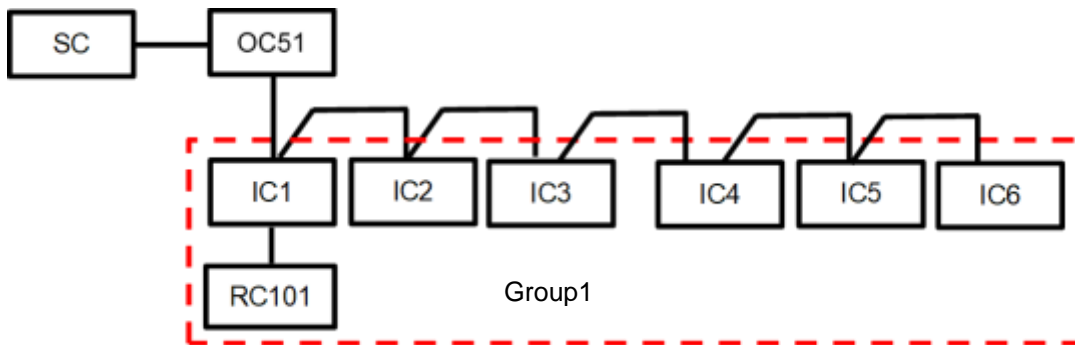

IC1 through IC6 are treated and diagnosed as a single category.

If there is only one category in a given refrigerant system, the LEVs will only be checked for being locked-close.

The Maintenance Tool will operate the indoor units in the "Test run/Cooling (Heating)/High fan speed" mode.

The units will remain on standby for 15 minutes until the control mode of the outdoor unit becomes stable.

After 15 minutes have passed, the diagnosis will begin.

(2) Diagnosis of indoor units being treated as two separate categories (A and B)

•When a given refrigerant system has two or more groups

Example. IC1 and IC2 are grouped as group 1, IC3 and IC4 are grouped as group 2, and IC5 and IC6 are grouped as group 3 from the centralized controller.

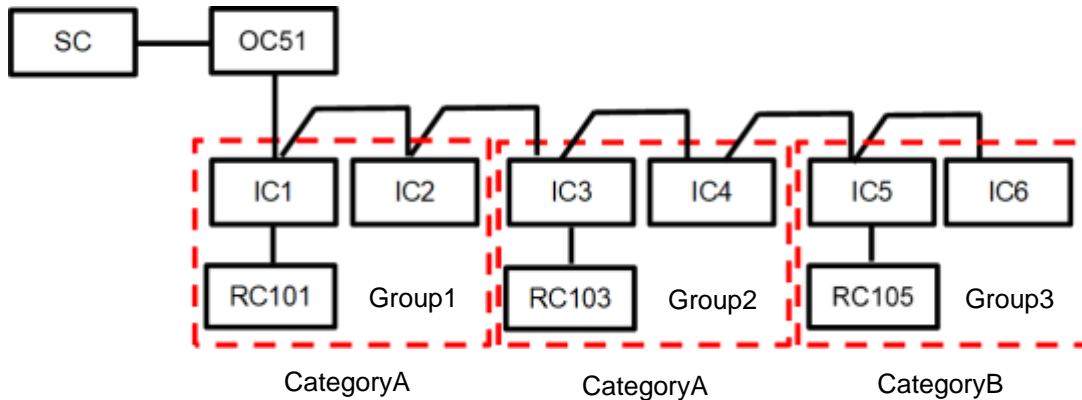

IC1 through IC4 are categorized as category A, and IC5 and IC6 are categorized as category B

When indoor units are categorized into two categories, the LEVs on indoor units in category A will be diagnosed for locked-close, and category B for locked-open.

The Maintenance Tool will operate the indoor units in category A in the “Test run/Cooling (Heating)/High fan speed” mode. Then, the Maintenance Tool will operate the indoor units in category B in the “Start/Fan/High fan speed” mode. The units will remain on standby for 15 minutes until the control mode of the outdoor unit becomes stable. After 15 minutes have passed, the diagnosis will begin.

Next, the LEVs on indoor units in category A will be diagnosed for locked-open, and category B for locked-close.

The Maintenance Tool will operate the indoor units in category A in the “Start/Fan/High fan speed” mode. Then, the Maintenance Tool will operate the indoor units in category B in the “Test run/Cooling (Heating)/High fan speed” mode. The units will remain on standby for 15 minutes until the control mode of the outdoor unit becomes stable. After 15 minutes have passed, the diagnosis will begin.

3.20.2 Restrictions and cautionary notes

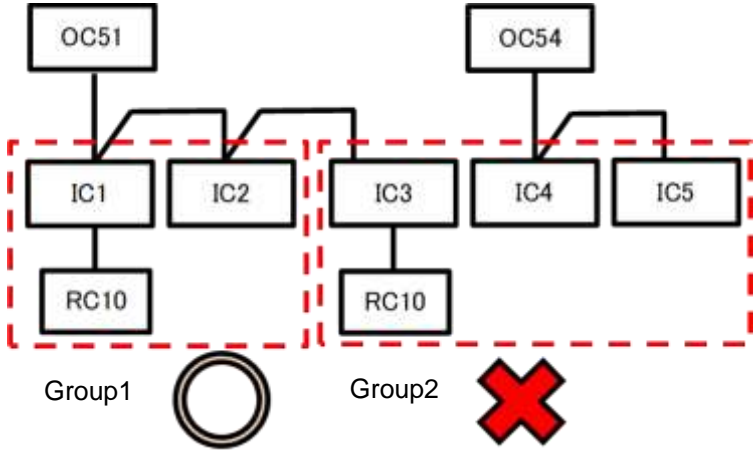
Function	Explanation
Restrictions and Cautions	<p>➤ This function will operate start/stop, operation mode, set temperature and air volume. Please note down these setting information before starting diagnosis, and restore its after diagnosis.</p> <p>➤ The types of equipment this function can diagnose are as follows: air-cooled and water-cooled Y/R2 series of R410A outdoor units except the cooling only model, BC controllers except the CMB-PW202V-J model, and Freeplan indoor unit.</p> <p>➤ Do not operate the air conditioning units during the diagnosis. Changing any setting from the local remote controller will adversely affect the diagnostic result.</p> <p>➤ Disable the timer and schedule functions if they are used.</p> <p>➤ The diagnosis may not properly performed when the outdoor unit frosts.</p> <p>➤ Diagnosis is impossible for indoor units that are grouped across outdoor units (Indoor units grouped in different refrigerant systems).</p> <p>Example:</p> 
Termination of diagnosis and termination conditions	<p>➤ The diagnosis will be canceled when the control mode becomes the stopping mode (including Error mode) or defrost mode.</p> <p>➤ Diagnosis of units that started having communication errors during diagnosis will be terminated.</p> <p>➤ If the diagnosis was not properly completed, check the error messages and the operating status of the units, and restart the diagnosis.</p>

3.20.3 Operation method

- (1) Start the Maintenance Tool, and search the address of the OC in the refrigerant system to be diagnosed.
To diagnose more than one refrigerant system simultaneously, search the addresses of all Ocs in the refrigerant systems to be diagnosed.

Note

Only the refrigerant systems that appear in the search result will be diagnosed.

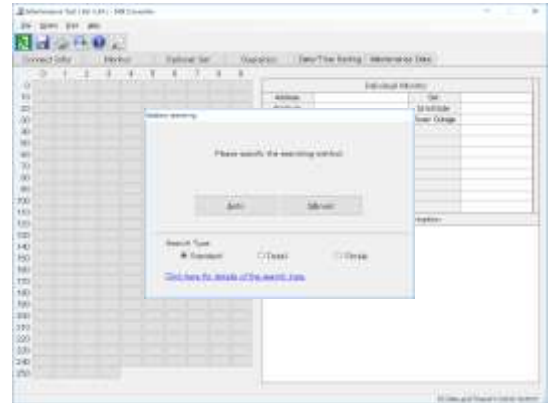

- (2) From the [Option] tab on the Main window, select [Error detection support function] and then [Indoor unit LEV problem detection support].

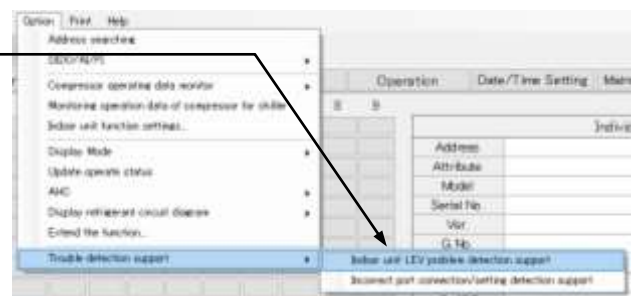

- (3) The diagnostic settings window will appear. Select the outdoor units to diagnose. There are two ways to select the outdoor units.

- ① All units: Select this option to diagnose all refrigerant systems whose addresses are displayed on the main window.
- ② Individual unit: Select this option to select the refrigerant systems to be diagnosed from the systems whose addresses are displayed on the main window.

Check that all units to be diagnosed are selected, and click [Next].

① All units



② Individual unit

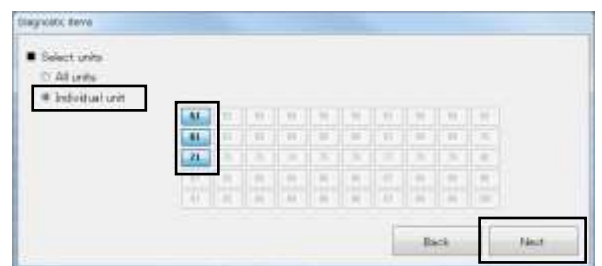

- (4) A confirmation window will appear. Note the approximate duration of diagnosis and restrictions that apply, and click **[Start]**.

Note

- LEV diagnosis will begin after the control function of the outdoor unit has stabilized. There will be an approximate 15-minute wait time for the diagnosis of locked-close status, and another 15 minutes for locked-open.
- If all of the entire refrigerant systems to be diagnosed have only one indoor unit group, diagnosis will be completed in approximately 30 minutes.
- If any of the refrigerant systems to be diagnosed has two or more indoor unit groups, diagnosis will be completed in approximately 45

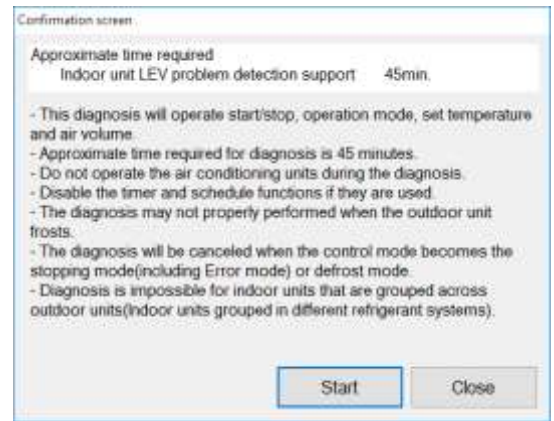

- (5) Based on the connection information of the units to be diagnosed, the diagnosis function will verify if all necessary unit information has been collected. Any missing information on the units will be collected.

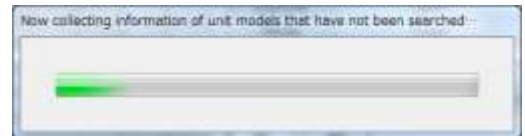

- (6) When all necessary information has been collected, the Operation Monitoring window will open. The Operation Monitoring window cannot be closed during diagnosis.

As shown in the figure at right, all menubars except  will be hidden, and the **[X]** will become unavailable for selection. Monitoring of operation will continue after the diagnosis is completed.

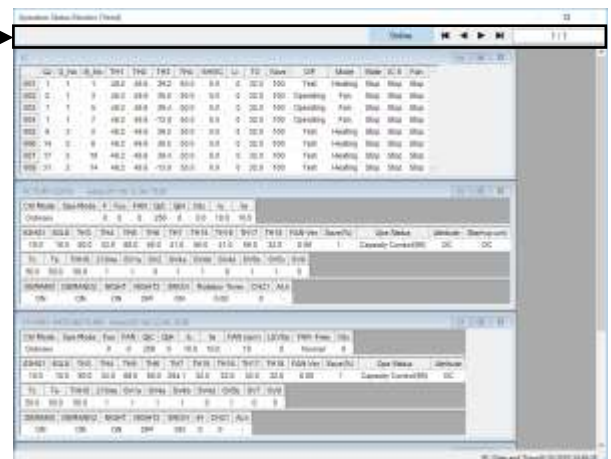

- (7) Diagnosis will begin.
Indoor units in each refrigerant system will be categorized based on their grouping status.

Note

- If a given refrigerant system has only one group, the LEVs will only be checked for being locked-close.
- If a given refrigerant system has two or more indoor unit groups, these groups will be divided into category A and category B, and diagnosis will proceed in the following order.

Category A: Diagnosed for locked-close
→ Diagnosed for locked-open
Category B: Diagnosed for locked-open
→ Diagnosed for locked-close

- All indoor units belonging to the same group will be categorized into the same category.



- (8) After grouping, the diagnostic results screen will appear.
For a refrigerant system with only one indoor unit category, information on all indoor units will appear in a single table.
For a refrigerant system with two or more indoor unit categories, information on indoor units in category A and category B will appear in separate tables.

- ① When a given system has only one indoor unit category



- (a) OC (address): Click the tab to toggle through the diagnostic results on different refrigerant systems. A maximum of 50 refrigerant systems can be displayed.

- ② When a given system has one or more indoor unit categories

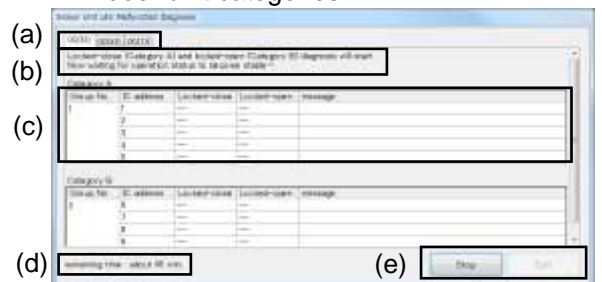

(b) The table below shows the diagnostic status of the refrigerant systems shown and the reasons for terminating the diagnostic process.

Diagnostic status and reasons for termination	Display content
Grouping of indoor units is in progress.	"Now grouping the indoor units..."
Diagnosis of locked-close is on hold until the unit operation becomes stable.	"Locked-close diagnosis will start. Now waiting for operation status to become stable..."
Waiting for the operation to become stable (1 st wait period)	"Locked-close (Category A) and locked-open (Category B) diagnosis will start. Now waiting for operation status to become stable..."
Waiting for the operation to become stable (2 nd wait period)	"Locked-open (Category A) and locked-close (Category B) diagnosis will start. Now waiting for operation status to become stable..."
Normal completion of diagnosis	"The diagnosis has been completed."
The outdoor unit went into the "Pipe cleaning" mode.	"The diagnosis has been canceled because the control mode switched to "Pipe cleaning" mode."
The outdoor unit went into the "Stop" mode.	"The diagnosis has been canceled because the control mode switched to "Stop" mode."
The outdoor unit went into the "Thermo-Off" mode.	"The diagnosis has been canceled because the control mode switched to "Thermo-Off" mode."
The outdoor unit went into the "Error" mode.	"The diagnosis has been canceled because the control mode switched to "Error" mode."
The outdoor unit went into the "Initial" mode.	"The diagnosis has been canceled because the control mode switched to "Initial" mode."
The outdoor unit went into the "Refrigerant leakage detection" mode.	"The diagnosis has been canceled because the control mode switched to "Refrigerant leakage" mode."
The outdoor unit went into the "Defrost" mode.	"The diagnosis has been canceled because the control mode switched to "Defrost" mode."
The operation of outdoor unit did not become stable.	"The diagnosis has been canceled because the operation status did not become stable."
Communication error	"The diagnosis has been canceled due to a communication error."
Grouping of indoor units connected to different outdoor units	"The diagnosis has been canceled because some indoor units are grouped across outdoor units (Indoor units grouped in different refrigerant systems)."
Failure to acquire the files containing unit model information during diagnosis	"The diagnosis has been canceled because the unit model information acquisition failed."
Diagnosis was terminated by the user	"The diagnosis has been completed."

(c) The table below shows indoor unit information and diagnostic results

Item	Explanation	Display content
Group No.	When a centralized controller such as AE-200 is connected to a given system, group information will be displayed.	"1", "2", "3" ...
	When no centralized controllers such as AE-200 are connected to a given system, no group information will be displayed.	"_"
IC address	IC addresses will be displayed.	"1", "2", "3" ...
Locked-close	The results of diagnosis of locked-close state will be displayed.	
	No LEVs being locked-close were found.	"OK"
	LEVs were found to be locked-close.	"Failed"
	No diagnosis of LEVs being locked-close was performed.	"_ _"
Locked-open	The results of diagnosis of locked-open state will be displayed.	
	No LEVs being locked-open were found.	"OK"
	LEVs were found to be locked-open.	"Failed"
	No diagnosis of LEVs being locked-open was performed.	"_ _"
Message Item	Messages regarding LEV status will be displayed.	
	Locked-close "OK": Locked-open "OK"	" " (A blank will appear.)
	Explanation	Display content
	Locked-close "OK": Locked-open "Failed"	"There is a possibility that the LEV is Locked-open or incompletely sealed. Please check the LEV."
	Locked-close "Failed": Locked-open "Failed"	"There is a possibility that the LEV is Locked. Please check the LEV."
	Indoor units that do not support the diagnosis function	"This unit model does not support the diagnosis function."
	Communication error during diagnosis	"The diagnosis has been canceled due to a communication error."

(d) The table below shows the overall progress and the results of diagnosis

Overall progress	Display content
When one or more refrigerant systems to be diagnosed have two or more indoor unit categories	"The remaining time will be counted down from approximately 45 minutes."
When all refrigerant systems to be diagnosed have only one indoor unit category	"The remaining time will be counted down from approximately 30 minutes."
Normal completion of the diagnosis of all refrigerant systems Diagnosis was terminated by the user	"The diagnoses for all systems have been completed."
Termination of the diagnosis of one or more refrigerant systems	"The diagnosis has been canceled in one or more systems because the operation status did not become stable."

(e) **[Stop]** and **[Close]**

Clicking **[Stop]** will display a confirmation pop-up. Clicking **[Yes]** will terminate the diagnosis, and the **[Close]** button will become active.

Clicking **[Close]** will display the Operation Monitoring window. Clicking **[No]** will continue the diagnosis.

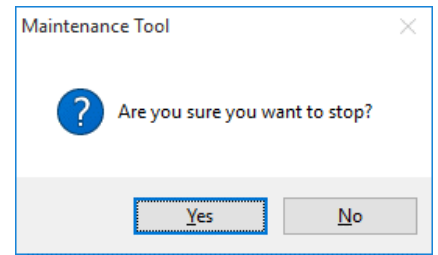

Diagnostic result example



3.20.4 Diagnostic results

When diagnosis is complete, a folder for storing the diagnostic results will be created in the “C:\¥MntToolNetEA¥Data” folder, and the following data will be stored in the folder.

The folder will be named based on the date and time when the [Start] button is clicked.

yyyyMMdd_HHmms (year/month/date_hour/minute/second)(Example: [Start] button clicked at 14 minutes and 15 seconds past 13 o'clock on April 1st, 2018: 20180401_131415)

- ① Window showing the diagnostic result of each refrigerant system [ext jpg]
Example: 20180401_131415(51)_result.jpg
- ② Operation data acquired by the “Operation data collection” function [ext MTDZ]
- ③ Text file containing the operation data acquired by the “Operation data collection” function [ext csv]
- ④ File in which error data for analysis will be stored [ext MTLZ]

3.21 Detection of the incorrect port connections/settings

*** Items Performed Here**

- This function helps detect incorrect port connections/settings for the simultaneous heating/cooling CityMulti system (R2).
Incorrect port connections/settings means that the port setting for a given indoor unit does not match the port number on the BC controller to which the indoor unit piping is connected.
Incorrect port connections/settings are detected by operating the indoor units **in each group** and studying the change in piping temperatures. Units are operated in the cooling mode when the outside temperature is 15°C or above, and in the heating mode when the outside temperature is below 15°C.
- Operation data collected during a diagnosis are automatically be saved and are available for viewing on the Offline analysis window after the diagnosis is completed.

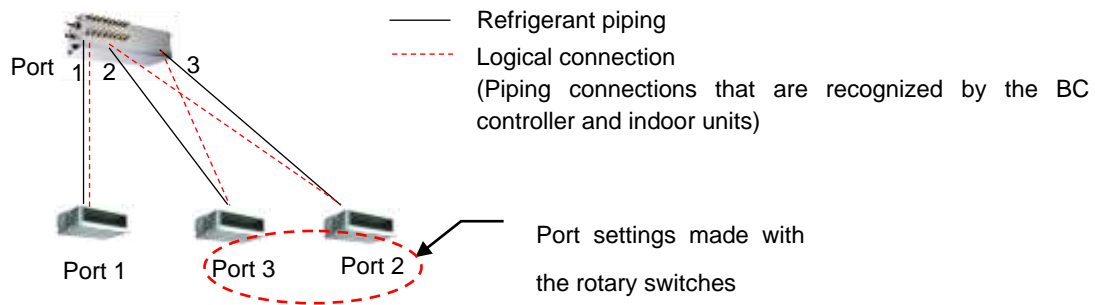

Example of an incorrect port connection/setting

3.21.1 Restrictions and cautionary notes

Function	Description
Restrictions and cautionary notes	<p>➤ This function helps detect incorrect port connections/settings. Actual port connections/settings need to be physically checked on site.</p> <p>➤ Units are operated by the groups, and incorrect port connections/settings within the same group are not detectable. When changes are made to the indoor unit group setting information, recheck the port for incorrect connections/settings using this function.</p> <div style="text-align: center;"> <p>The diagram illustrates two scenarios of port connections between an outdoor unit and indoor units across different groups. In the 'Detectable' scenario, the outdoor unit is connected to Port 1 of Group1, Port 3 of Group2, and Port 2 of Group2. In the 'Not detectable' scenario, the outdoor unit is connected to Port 2 of Group1, Port 1 of Group1, and Port 3 of Group2. A red 'X' is placed over the Group1 connections in the 'Not detectable' scenario, indicating that incorrect connections within a group are not detectable.</p> </div> <p>➤ The diagnostic process will be cancelled if the operation status of the air conditioning units being diagnosed changes during a diagnosis due to an operation mode change from a remote controller or a breaker trip.</p> <p>➤ Indoor units will stop after completion of the diagnosis. Restart the indoor units as necessary.</p> <p>➤ If the outdoor unit fails to go into operation within 15 minutes due to communication error or for other reasons, the incorrect port connection/setting detection function will be cancelled.</p>

3.21.2 Operation method

- (1) From the **[Option]** tab on the Main window, select **[Error detection support function]** and then **[Incorrect port connections/settings detection support]**.

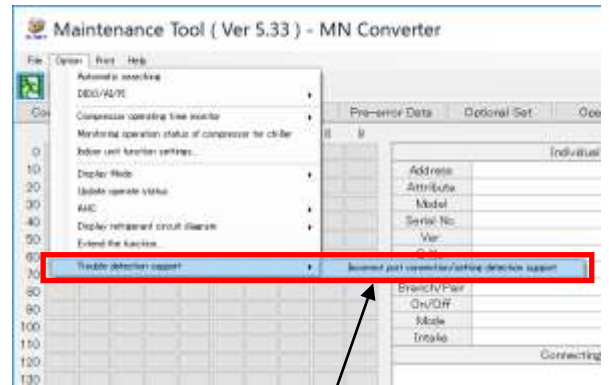

Detection of the incorrect port connections/settings

- (2) The progress bar will appear, and then the **[Diagnostic settings]** window will appear.

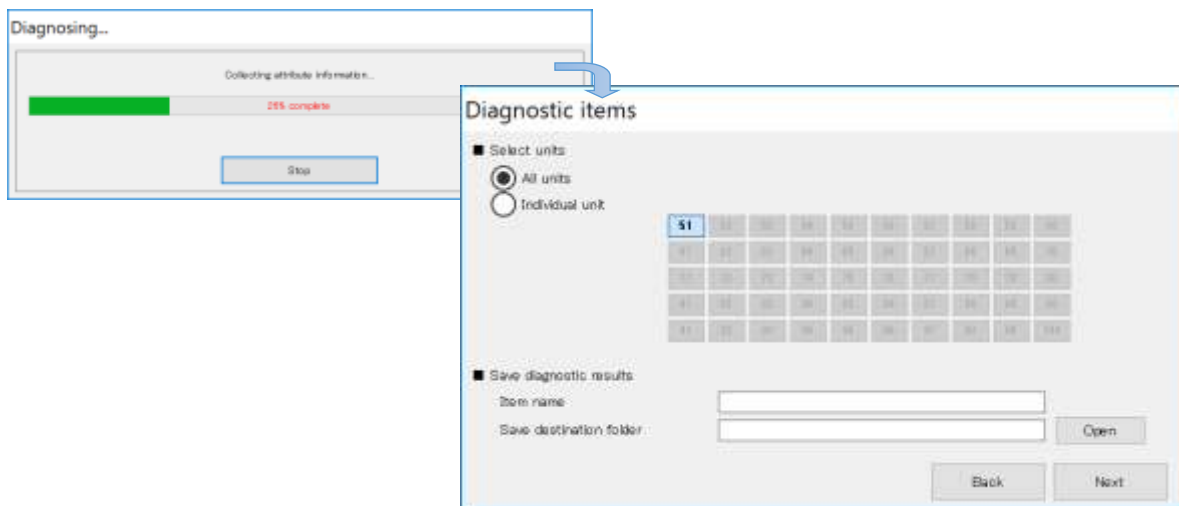

[Selecting the units to diagnose]

Select the system to be diagnosed from the unit selection menu. Select **[All units]** to select all systems whose attribute is OC on the M-NET system. Select **[Individual]** to select the diagnosis target individually.

[Saving the diagnostic results]

Select the site name and the save-destination folder to save and the output data. See “3.21.3 Diagnostic results” for the types of data that will be saved.

Select the units to be diagnosed, enter the save- destination folder for the diagnostic results, and click **[Next]**.

- (3) The confirmation window will appear. Read the cautionary notes for using this function, and then click **[Start]**.

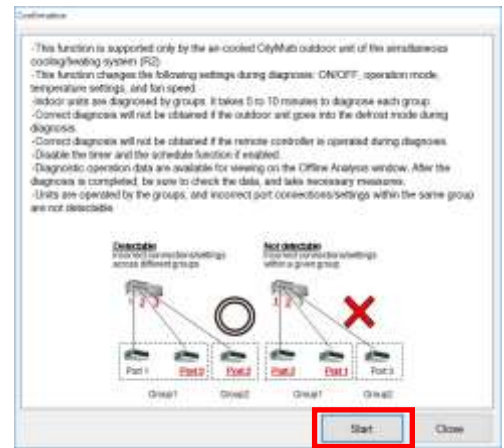

Start

Note

It will take approximately [15 minutes + Number of groups x 5 minutes] to complete the diagnosis of a refrigerant system using the incorrect port connections/settings function. 15 minutes are the sum of the time it takes to check the system settings (5 minutes), start the outdoor unit (5 minutes), and perform other processes (5 minutes). It takes approximately 5 minutes to diagnose each group if the port connections/settings are normal, but takes approximately 10 minutes if the port connections/settings are incorrect.

- (4) Detection of incorrect port connections/settings will begin, and the operation monitor window and the progress bar will appear on the screen. Clicking **[Cancel]** will cancel the process.

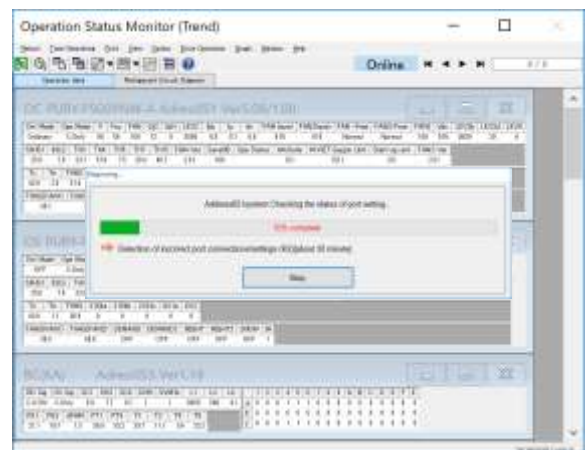

(5) Diagnostic results will appear upon completion of the diagnosis. Take appropriate measures based on the diagnosis.

Detection of incorrect port connections/settings (R2)				
	OC address	Group	IC address	Error code
Stop	51			2

Port connection/setting check results

OK : The port settings are correctly set.

Fail : The port settings may not be correctly set.
Check the port settings.

Cancel : Diagnosis was cancelled.

Diagnosis will be cancelled when the outdoor unit operation is stopped by the user or the unit goes into a defrost mode or other modes not supported by the diagnostic function.

Restart the diagnosis.

Not supported: The outdoor unit with the selected address does not support the function.

Note

Groups without connection to the centralized controller will appear as "-" in the "Group" column.

3.21.3 Diagnostic results

When diagnosis is done, the following data will be saved in the folder that was designated in the Diagnostic settings window. Review the diagnostic results as necessary.

- ① Diagnostic results [extension jpg]
- ② Operation data [extension MTDZ]
- ③ ② in the CSV format file [extension CSV]
- ④ Diagnostic result log [extension MTLZ]

3.22 HVRF-R2 installation support function

* Features

- The HVRF-R2 installation support function enables the HVRF-R2 units to perform the debris removal operation and the air vent operation with the Maintenance Tool. Conventionally, the debris removal operation and the air vent operation cannot be performed unless the installation of the outdoor unit/heat-source unit (hereinafter referred to as outdoor unit), HBC controller, and indoor unit has been completed. The HVRF-R2 installation support function allows the HVRF-R2 units to perform these operations upon completion of installation of the HBC controller and the indoor unit.

3.22.1 System configuration

To use the HVRF-R2 installation support function, configure the system as follows.

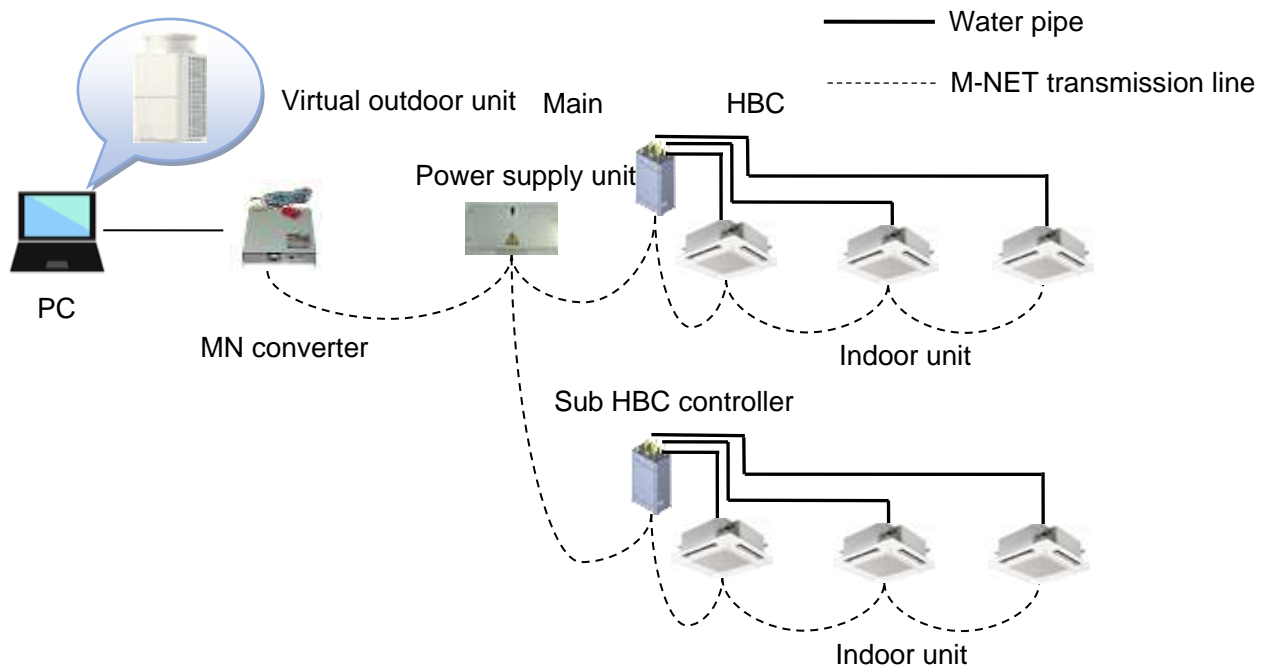

No.	Device	Description
1	PC	PC on which the Maintenance Tool is installed. In the HVRF-R2 installation support function, the Maintenance Tool works as a virtual outdoor unit. The HBC controller and the indoor unit operate as if the outdoor unit was connected, allowing the debris removal operation and the air vent operation to be performed without the outdoor unit being connected.
2	MN converter	Used to connect a PC to the M-NET transmission line. The HVRF-R2 installation support function works with any models of MN converter.
3	Power supply unit	Used to supply power to the M-NET transmission line. The outdoor unit usually supplies power to the M-NET transmission line. The M-NET transmission line in the system shown in the figure above requires the power supply unit because there is no outdoor unit. Use PAC-SC51KUA.
4	HBC controller	There are two types of HBC controllers: "Main HBC controller (with pump)" and "Sub HBC controller (without pump)." The HVRF-R2 installation support function supports only vertical type Main-HBC(Horizontal type Main-HBC is unsupported).
5	Indoor unit	The HVRF-R2 installation support function works with any models of indoor unit.

NOTE:

With the HVERF-R2 installation support function, the debris removal operation and the air vent operation cannot be performed in systems containing multiple main HBC controllers.

To perform the HVERF-R2 installation support function in multiple systems, perform the debris removal operation and the air vent operation for each system.

The HVERF-R2 installation support function cannot be used for systems containing multiple main HBC controllers.

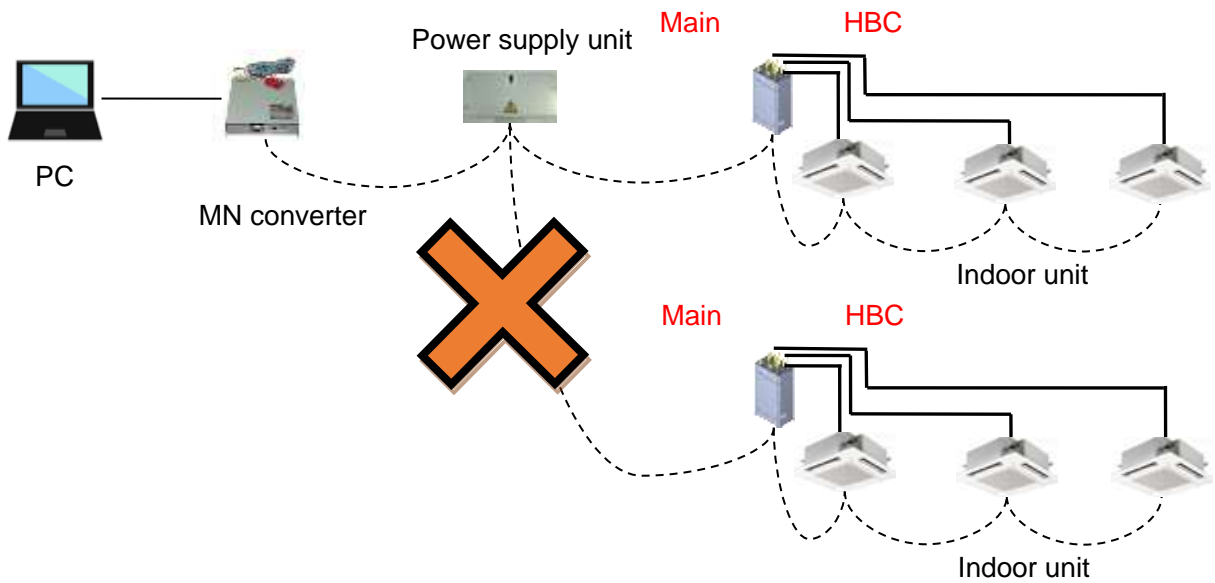

The HVERF-R2 installation support function can be used for systems containing one main HBC controller.

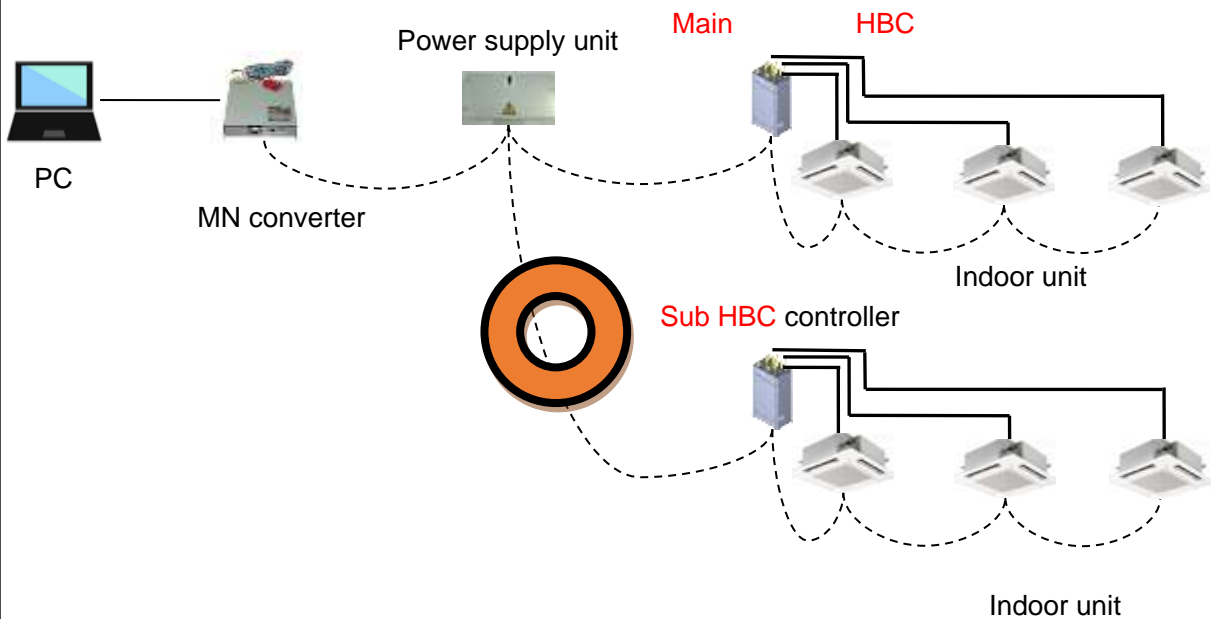

3.22.2 Overview of the system configuration procedure

The following flowchart shows the procedure for configuring the HVRF system with the Maintenance Tool. The Maintenance Tool supports the steps "Debris removal operation" and "Air vent operation STEP 1 through STEP 3." Follow the conventional procedure for other steps.

This manual describes the procedures only for "Debris removal operation" and "Air vent operation STEP 1 through STEP 3" that are highlighted in yellow in the figure below. See the Installation Manual or the Service Handbook for the procedure for other steps.

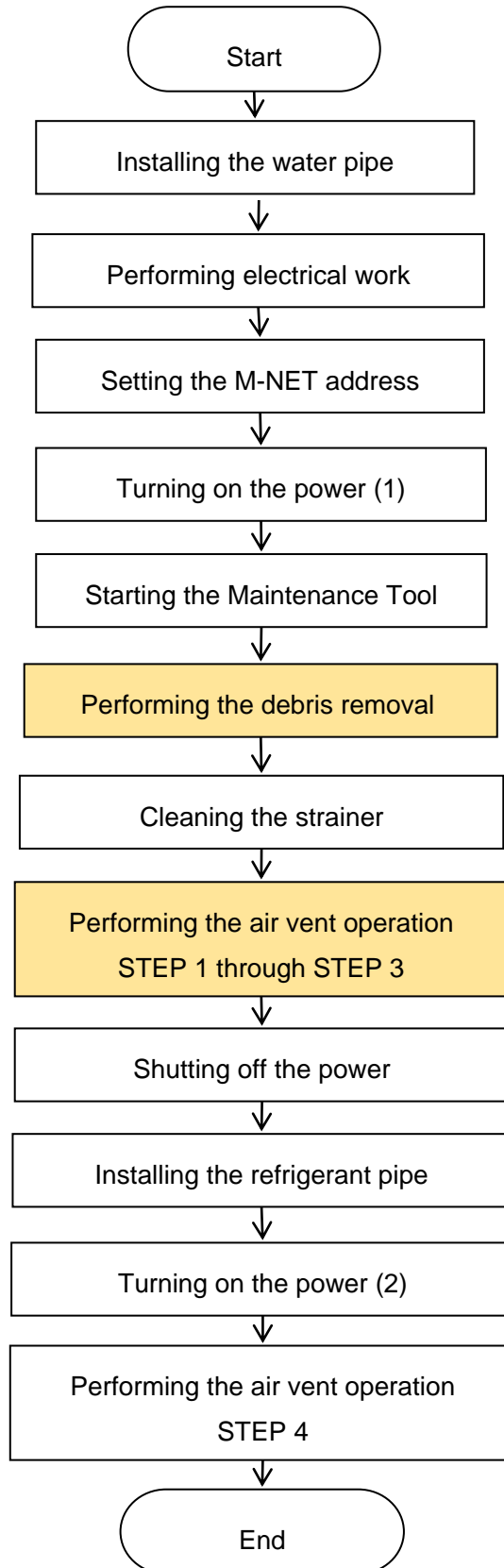

3.22.3 Procedure ("Installing the water pipe" through "Turning on the power (1)")

Install the water pipe, perform electrical work, set the M-NET address, and set the branch port address of the indoor unit by referring to the Installation Manual.

When the HVRF-R2 installation support function is used, the automatic M-NET address assignment function cannot be used. Manually assign an arbitrary M-NET address.

After the procedures above have been completed, connect the power supply unit to the M-NET transmission line. Then, turn on the power of the HBC controller, indoor unit, and power supply unit.

3.22.4 Procedure ("Starting the Maintenance Tool" through "Cleaning the strainer")

Connect the MN converter to the M-NET transmission line, and start the Maintenance Tool.

- (9) Click [Option] > [Commissioning support] > [HVRF-R2 commissioning].

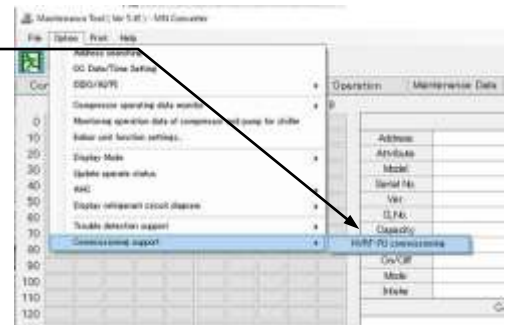

- (10) A confirmation window will appear. Check the details, and click [Next].

To open the manual (this document), click [Open manual].

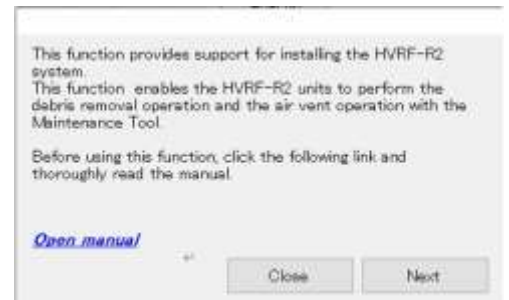

- (11) A progress bar will appear. An error message will appear if there is a problem with the system configuration. If the error message appears, take corrective actions according to the table below, and restart from step (1).



Error message	Corrective action
HBC controller with the M-NET address ** does not support the HVRF-R2 installation support function.	The HVRF-R2 installation support function works only for the HBC controller installed vertically. For other HBC controllers, install the outdoor unit to perform the debris removal operation and the air vent operation.
HBC controller does not exist.	Check that the HBC controller is connected to the M-NET transmission line.
Two or more main HBC controllers exist.	With the HVRF-R2 installation support function,

Check the system configuration.	the debris removal operation and the air vent operation cannot be performed in systems containing multiple main HBC controllers. Perform the debris removal operation and the air vent operation for each system.
Four or more sub HBC controllers exist. Check the system configuration.	
M-NET address ** is set to the device other than the HBC controller. To use the HVRF-R2 installation support function, disconnect the devices other than HBC controllers and ICs from the M-NET transmission line.	Separate the devices other than the HVRF system (such as the VRF system and chiller) from the M-NET transmission line.

(12) The startup window of the virtual outdoor unit appears.
 The virtual outdoor unit communicates with the HBC controller and the indoor unit to perform startup processing. Wait until the startup processing is completed.
 The startup processing will be completed in about three minutes.



NOTE:

The service LED of the virtual outdoor unit appears on the Maintenance Tool window. The horsepower, software version, M-NET address, and refrigerant information of the virtual outdoor unit are displayed alternately. If an error occurs, an error code will be displayed. If the error code is displayed, see the Service Handbook, and take corrective action.

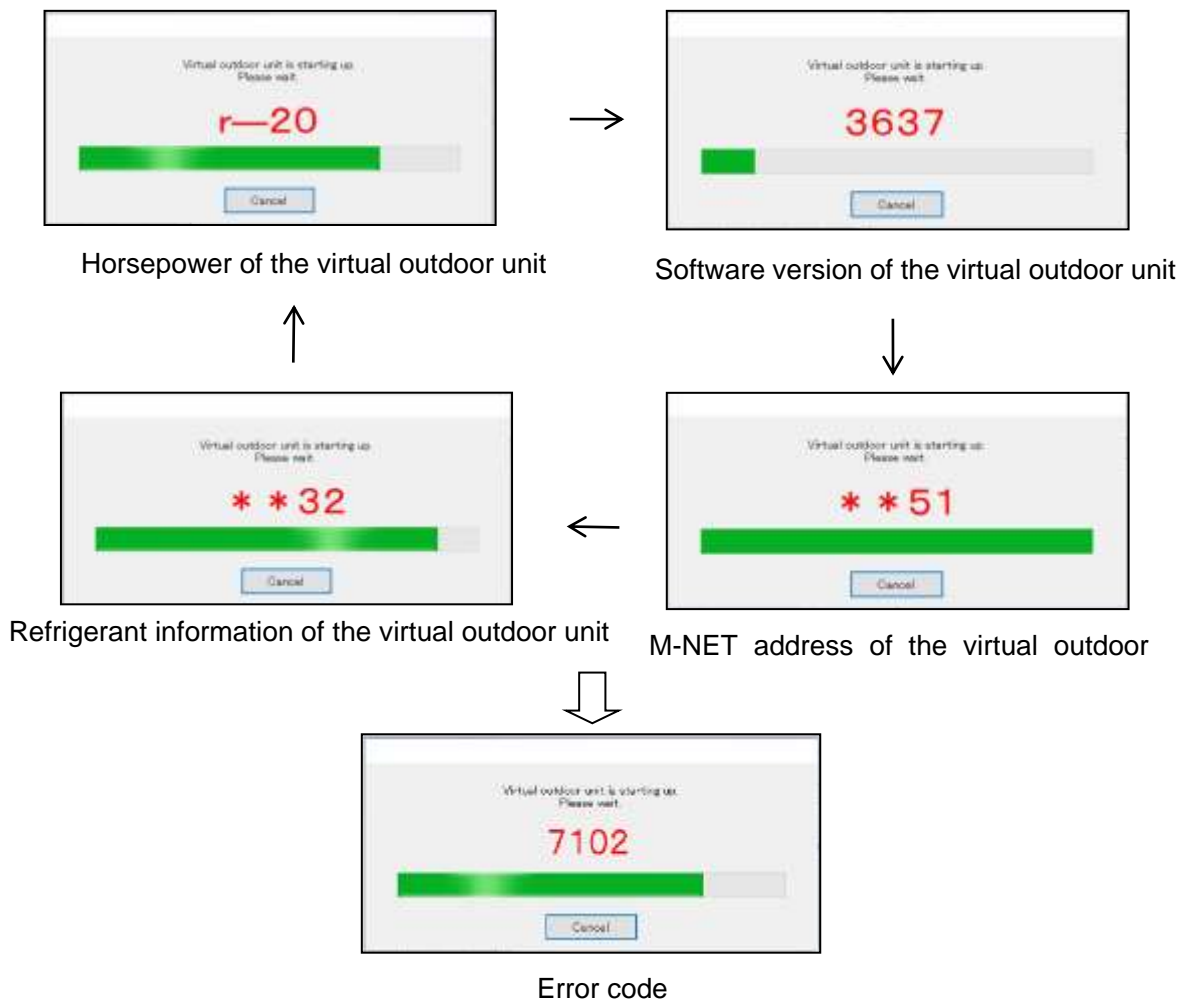

- (13) When the startup of the virtual outdoor unit has been completed, a preparation window will appear.
By referring to "Instructions for Debris Removal Operation" in the Service Handbook, make preparation for the debris removal operation, and perform the debris removal operation by setting DipSW002-1 on the main HBC controller to ON.

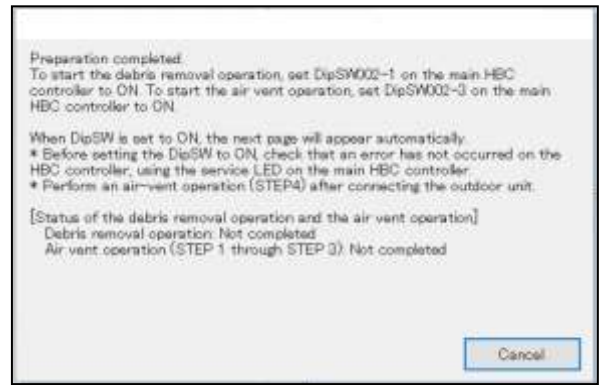

- (14) When DipSW002-1 on the main HBC controller is set to ON, the Maintenance Tool window changes to the next page, and the debris removal operation starts. Wait until the debris removal operation is completed.
The progress of the debris removal operation is not displayed in the Maintenance Tool window. To check the progress, see the service LED on the main HBC controller.

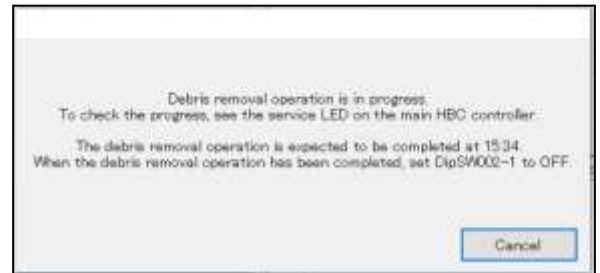

- (15) When the debris removal operation has been completed, set DipSW002-1 on the main HBC controller to OFF. The Maintenance Tool window will change to the next page. Check that "Debris removal operation: Completed" is displayed.

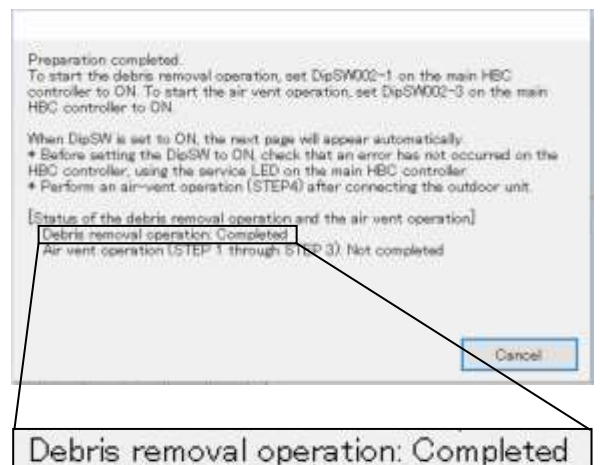

- (16) Clean the strainer by referring to the instructions in the Service Handbook.

3.22.5 Procedure ("Air vent operation STEP 1 through STEP 3" through "Shutting off the power")

- (1) By referring to "Instructions for the Air Vent Operation" in the Service Handbook, make preparation for the air vent operation, and perform the air vent operation by setting DipSW001-10 to OFF and then setting DipSW002-3 to ON on the main HBC controller.

When DipSW002-3 is set to ON, the Maintenance Tool window changes to the next page, and the air vent operation (STEP 1 through STEP 3) starts. Wait until the air vent operation (STEP 1 through STEP 3) is completed. As with the debris removal operation, check the progress, using the service LED on the main HBC controller.

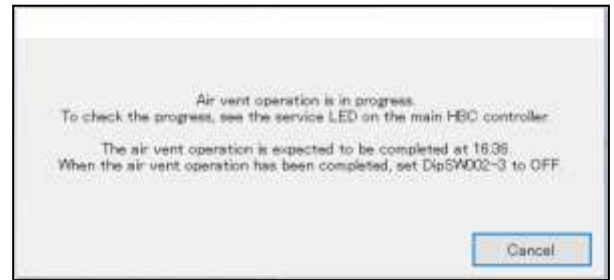

NOTE:

Before performing the air vent operation using the Maintenance Tool, set Dip-SW1-10 on the main HBC controller to OFF. When DipSW2-3 is set to ON while DipSW1-10 is set to ON, the air vent operation (STEP 4) will be performed and stopped abnormally because the air vent operation (STEP 4) requires installation of the outdoor unit.

- (2) When the air vent operation (STEP 1 through STEP 3) has been completed, set DipSW002-3 on the main HBC controller to OFF. The Maintenance Tool window will change to the next page. Check that "Air vent operation: Completed" is displayed. The Maintenance Tool will not be used in the further steps. Click [Cancel] to exit the Maintenance Tool.

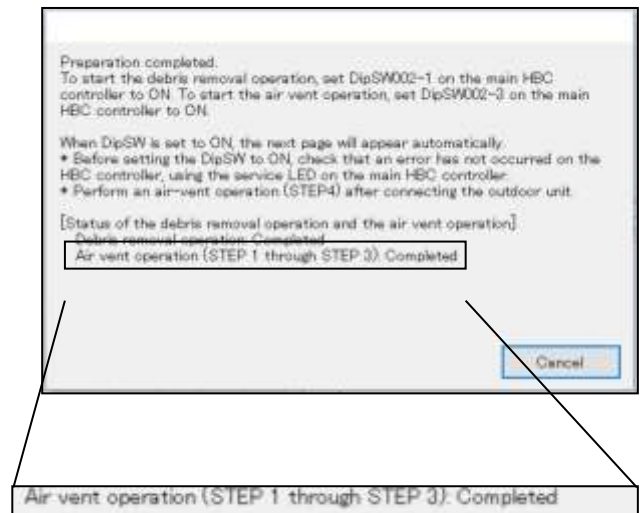

- (3) Turn off the power of the HBC controller, indoor unit, and power supply unit, and then disconnect the power supply unit. This step completes the debris removal operation and the air vent operation from the Maintenance Tool.

NOTE:

Install the refrigerant pipe, and perform the air vent operation (STEP 4) by referring to the Installation Manual and the Service Handbook. Note that only the air vent operation (STEP 4) can be performed by setting DipSW001-10 on the main HBC controller to ON.

3.22.6 Restrictions and precautions

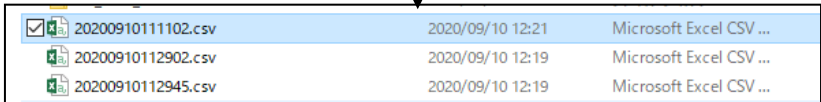
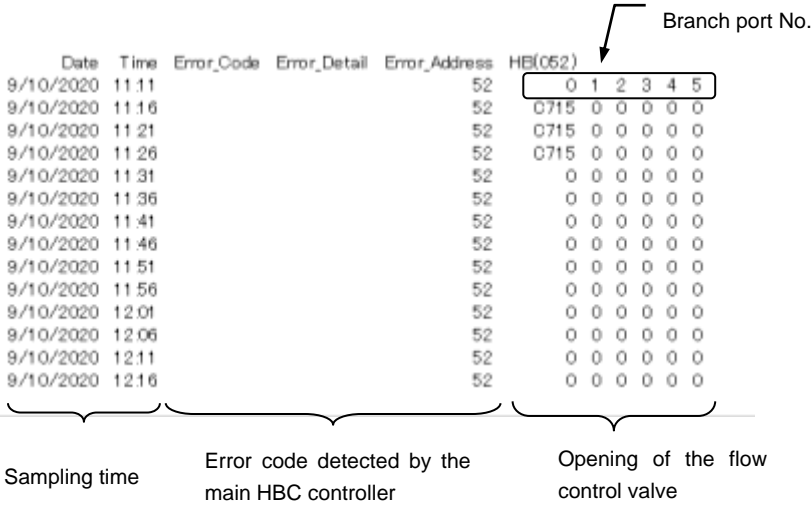
Restrictions and precautions	Description																																																																																										
Exit from the Maintenance Tool	<p>Do not exit the Maintenance Tool or disconnect the MN converter or the power supply unit from the M-NET transmission line during debris removal operation or air vent operation to prevent error from occurring.</p> <p>If an error occurs, perform the debris removal operation or the air vent operation again from the first step.</p>																																																																																										
In the event of a power failure	<p>If a power failure occurs, perform the debris removal operation or the air vent operation again from the first step.</p>																																																																																										
If an error occurs during the debris removal operation or the air vent operation	<p>If an error occurs during debris removal operation or air vent operation, check the log file stored in the "C:\MntToolNetEA\Data" folder.</p> <p>The log file name is "year, month, hour, minute, and second when the Maintenance Tool is started" + ".csv".</p> <div data-bbox="593 801 1417 902" style="border: 1px solid black; padding: 5px; margin: 10px 0;">  </div> <p>The log file records the error code detected by the HBC controller and the opening of the flow control valve. If an error occurs, take measures according to the information in the log file.</p> <table border="1" data-bbox="614 1115 1332 1467" style="width: 100%; border-collapse: collapse; text-align: center;"> <thead> <tr> <th>Date</th> <th>Time</th> <th>Error_Code</th> <th>Error_Detail</th> <th>Error_Address</th> <th>HB(052)</th> </tr> </thead> <tbody> <tr> <td>9/10/2020</td> <td>11:11</td> <td></td> <td></td> <td>52</td> <td>0 1 2 3 4 5</td> </tr> <tr> <td>9/10/2020</td> <td>11:16</td> <td></td> <td></td> <td>52</td> <td>0715 0 0 0 0 0</td> </tr> <tr> <td>9/10/2020</td> <td>11:21</td> <td></td> <td></td> <td>52</td> <td>0715 0 0 0 0 0</td> </tr> <tr> <td>9/10/2020</td> <td>11:26</td> <td></td> <td></td> <td>52</td> <td>0715 0 0 0 0 0</td> </tr> <tr> <td>9/10/2020</td> <td>11:31</td> <td></td> <td></td> <td>52</td> <td>0 0 0 0 0 0</td> </tr> <tr> <td>9/10/2020</td> <td>11:36</td> <td></td> <td></td> <td>52</td> <td>0 0 0 0 0 0</td> </tr> <tr> <td>9/10/2020</td> <td>11:41</td> <td></td> <td></td> <td>52</td> <td>0 0 0 0 0 0</td> </tr> <tr> <td>9/10/2020</td> <td>11:46</td> <td></td> <td></td> <td>52</td> <td>0 0 0 0 0 0</td> </tr> <tr> <td>9/10/2020</td> <td>11:51</td> <td></td> <td></td> <td>52</td> <td>0 0 0 0 0 0</td> </tr> <tr> <td>9/10/2020</td> <td>11:56</td> <td></td> <td></td> <td>52</td> <td>0 0 0 0 0 0</td> </tr> <tr> <td>9/10/2020</td> <td>12:01</td> <td></td> <td></td> <td>52</td> <td>0 0 0 0 0 0</td> </tr> <tr> <td>9/10/2020</td> <td>12:06</td> <td></td> <td></td> <td>52</td> <td>0 0 0 0 0 0</td> </tr> <tr> <td>9/10/2020</td> <td>12:11</td> <td></td> <td></td> <td>52</td> <td>0 0 0 0 0 0</td> </tr> <tr> <td>9/10/2020</td> <td>12:16</td> <td></td> <td></td> <td>52</td> <td>0 0 0 0 0 0</td> </tr> </tbody> </table> <div style="margin-top: 10px;">  </div>	Date	Time	Error_Code	Error_Detail	Error_Address	HB(052)	9/10/2020	11:11			52	0 1 2 3 4 5	9/10/2020	11:16			52	0715 0 0 0 0 0	9/10/2020	11:21			52	0715 0 0 0 0 0	9/10/2020	11:26			52	0715 0 0 0 0 0	9/10/2020	11:31			52	0 0 0 0 0 0	9/10/2020	11:36			52	0 0 0 0 0 0	9/10/2020	11:41			52	0 0 0 0 0 0	9/10/2020	11:46			52	0 0 0 0 0 0	9/10/2020	11:51			52	0 0 0 0 0 0	9/10/2020	11:56			52	0 0 0 0 0 0	9/10/2020	12:01			52	0 0 0 0 0 0	9/10/2020	12:06			52	0 0 0 0 0 0	9/10/2020	12:11			52	0 0 0 0 0 0	9/10/2020	12:16			52	0 0 0 0 0 0
Date	Time	Error_Code	Error_Detail	Error_Address	HB(052)																																																																																						
9/10/2020	11:11			52	0 1 2 3 4 5																																																																																						
9/10/2020	11:16			52	0715 0 0 0 0 0																																																																																						
9/10/2020	11:21			52	0715 0 0 0 0 0																																																																																						
9/10/2020	11:26			52	0715 0 0 0 0 0																																																																																						
9/10/2020	11:31			52	0 0 0 0 0 0																																																																																						
9/10/2020	11:36			52	0 0 0 0 0 0																																																																																						
9/10/2020	11:41			52	0 0 0 0 0 0																																																																																						
9/10/2020	11:46			52	0 0 0 0 0 0																																																																																						
9/10/2020	11:51			52	0 0 0 0 0 0																																																																																						
9/10/2020	11:56			52	0 0 0 0 0 0																																																																																						
9/10/2020	12:01			52	0 0 0 0 0 0																																																																																						
9/10/2020	12:06			52	0 0 0 0 0 0																																																																																						
9/10/2020	12:11			52	0 0 0 0 0 0																																																																																						
9/10/2020	12:16			52	0 0 0 0 0 0																																																																																						

4

Off-Line Monitor Operating Method

4.1 Off-Line Monitor Screen Transfer

Title Screen



Operation Monitor



(Operation status monitor screen)

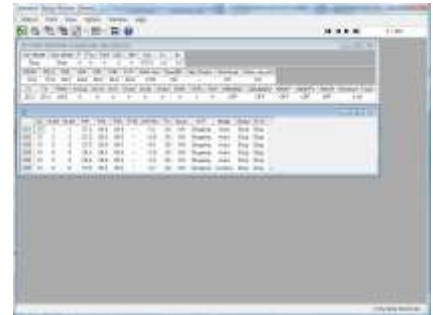

(Operation monitor

Data list screen)



System Information



Monitoring of Pre-error Data



(System info. Data list screen)

(Pre-error Data list screen)

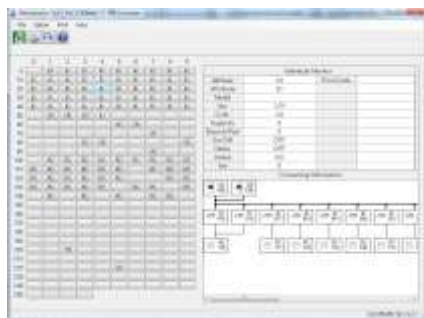

(System information screen)



(Pre-error data screen)

4.2 Function Chart

4.2.1 Operation Monitor

Off-Line Analyzing ----- [Refer to 4.3.1]

Monitors and prints about unit data and the refrigerant circuit diagram saved in On-Line “**3.8 Operation Monitor**”.

Check Mail ----- [Refer to 4.3.2]

Extracts the operation monitoring data being mail-transferred by the remote monitor mode from the mail server.

4.2.2 System Information Monitor

Off-Line Analyzing ----- [Refer to 4.4.1]

Monitors and prints about unit data saved in On-Line “**3.4 Main Screen**”.

4.2.3 Monitoring of Pre-error Data

Off-Line Analyzing ----- [Refer to 4.5.1]

Monitors and prints about unit data saved in On-Line “**3.11.1.2 Monitoring of Pre-error data**”.

4.2.4 Compressor operating data monitor

Off-Line Analyzing ----- [Refer to 4.6.1]

Monitors and prints about unit data saved in On-Line “**3.16 Compressor operating data monitor**”.

4.2.5 Function common for each screen (Filing operation)

Delete Data ----- [Refer to 4.7.1]

The offline data selected can be deleted.

Export ----- [Refer to 4.7.2]

Allows to output the off-line data selected on the screen as a separate file from the database.

Import ----- [Refer to 4.7.3]

Allows to take the off-line data being output as a file by Export into the database.

Text Convert ----- [Refer to 4.7.4]

Allows to output the off-line data being displayed on the screen as a file in Text format from the database. The system information data can not be converted. The Pre-error data can be converted in text on Offline Analysis Screen.

Monitor Data information edit ----- [Refer to 4.7.5]

Allows to edit the name of Monitor Data or other relevant information.

Right-clicking menu ----- [Refer to 4.7.6]

The items that can be set are same as that of the function button on the screen listing each data.

Malfunction Log Data ----- [Refer to 4.7.7]

Allows to open The folder of data file by the Explorer.

4.2.6 Offline Analyze on Wide area access mode

Off-Line Analyzing ----- [Refer to 4.8.1]

Allows to edit the monitored name.

4.2.7 Offline Analyze on Initial settings of AHC

Off-Line Analyzing ----- [Refer to 4.9.1]

Allows to edit the the initial AHC settings.

- Changing the name of monitor data

You may change the monitor data name on the screen of the data list.

- Right-clicking menu

Clicking the right button of the mouse on the [Monitor data] desired to be operated displays the pop-up menu. Using the pop-up menu facilitates your operation.

- Malfunction Log Data

The folder where the CSV file (Malfunction Log etc.) is stored can be displayed.

- The offline mode includes 2 types, the [normal mode] and [wide area access mode].

Although the functions of both modes are almost same, however, under the [wide area access mode], the following functions are provided additionally.

1) Display of monitored name objective for data collection

The [AREA name], [Customer] and [Air conditioning system name] are shown for each data obtained.

2) Display of extracted data

By selecting [AREA name] and [Customer name], the relevant data only can be displayed.

NOTE: Both the data obtained by online under normal mode and that under wide area access mode can be displayed commonly under both offline modes.

- Connecting to P/M series

In case of connection using USB / Serial conversion cable, the applicable items are following.

- Operation monitor[Refer to 4.2.1]
- Function common for each screen (Filing operation)[Refer to 4.2.5]

4.3 Operation Monitor

* Items Performed Here

- Monitors and prints about the System Information and the Operating Data of units saved using the on-line monitor.

4.3.1 Off-Line Analyzing

(1) Click on **Monitor** to display the data list screen of Operation Monitor.

(2) Click on **[Monitor Data]** desired to be monitored.

(3) Click on **Offline Analyze**.



NOTE:

This covers the operation with the menu of the right-clicking of the mouse.
(Refer to 4.7.6 Right-clicking menu.)

(4) **Operation Status Monitor Screen**

(a) Click on the buttons to display data from oldest or one minute before or one minute after or Latest.
This feature is supported in the "Operation Data" screen only.

(b) **"Menu Bar"**

The menu bar displays **[Return]**, **[Print]**, **[View]**, **[Time Search]**, **[Option]**, **[Help]**.

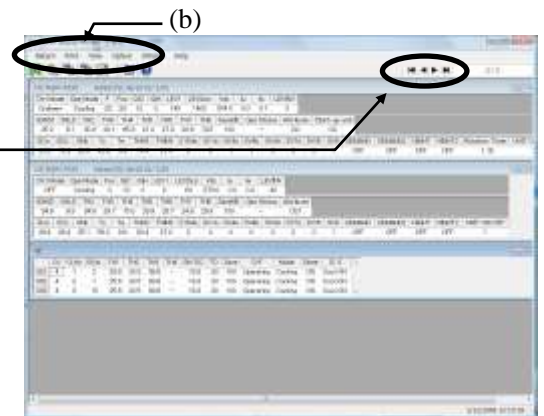

- Click on **[Return]** to end the **Operation Status Monitor Screen**.
[Refer to (c)]

- Click on **[Print]** and then select **"Print"** from the **sub-menu**.

The hard copy of the screen will be printed from the connected printer.



- Click on **[Time Search]** and the **Time Searching Screen** will appear.

Enter the **[Date]** and **[Time]**.
(When entering the time, refer to the monitor data time.)

Once the time has been entered, click on **Time Searching**.

The entered data will appear.
If no time data has been entered, data for the nearest time will appear.



NOTE:

Set the data/time to be entered to the time presented within the monitor data.
Setting to the time outside of the monitor time may cause to disable the search function.

- Click on **[View]** and then select “**Switch Trend Form**” or “**Switch Classic Form**” from the **sub-menu**. Change the display format.
- Click on **[Help]** and “**Explanation of Terminology**” and “**Operation Method**” sub-menus can be selected.

[Refer to **3.6.1 Connecting Information of outdoor units 3.6.1.2 (2) “Menu Bar”**]

- (c) Click on **[Return]** on the menu bar to end the **Operation Status Monitor Screen**. The screen returns to the data list screen of Operation Monitor.

4.3.2 Check mail

*Mail Server Setting

In order to provide mail checking to the operation data mail-messaged from Centralized Controller by utilizing Mail communication mode under online mode, the setting is required relating to the connection of the objective mail server.

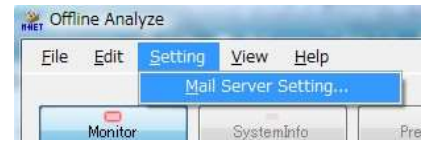

- (a) Clicking on the sub-menu **“Mail server setting”** of **“Setting”** on the menu bar displays **Mail server setting screen**.

NOTE:
 •[Mail Server Setting] will not be available for selection by non-administrative users.

- (b) For lan connection, click on **“LAN,”** set the items relating to mail servers, and click on  .

Items to be set

- Pop server :Ip address of mail servers for receiving
- User name :User name for mail receiving
- Password :Password for mail receiving







- (c) For dialup connection, click on **“Dialup Network,”** set the items relating to dialup and mail servers, and click on  .

Items to be set

- Connection name:dialup connection name (requires to set the information on the provider to be connected by [dialup connection] from [control panel])
- Dialup user name :user name for dialup connection
- Dialup password :password for dialup connection
- POP Server :IP address of mail servers for receiving
- User Name :User name for mail receiving
- Password :Password for mail receiving

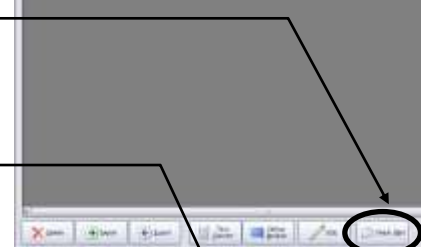
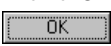
* When there are many amounts of data, this several hours case is in update of monitor data. We recommend you to set up so that interval time may be inputted into “POP Receive Interval” of “Mail Server Setting” and a mail check may be carried out periodically. (A mail check is automatically performed at the set-up interval.)

- (1) Click on  to display the data list screen of Operation Monitor. 
- (2) Click on  . Initiates the checking of the operation monitor data mail for the mail server, and storing of the acquired data. During the data transferring and storing, the progress rate will be displayed. 
- (3) After completing of data transfer and storing, the numbers of received mail will be displayed. (The numbers of the received mail counted here have no relation with the numbers displayed on the monitor data.) Clicking on  returns to the data list screen of Operation Monitor. 

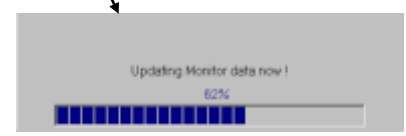

*The capacity to store the data obtained by the Maintenance Tool counts for 2G-bite maximum. When the remaining storage capacity is getting insufficient during data reception by mail, Warning Screen will appear. In this case, suspend the mail checking, and delete unnecessary data on Offline Screen to keep a proper capacity.

NOTE:

- [Check Mail]] will not be available for selection by non-administrative users.

4.4 System Information

4.4.1 Off-Line Analyzing

- (1) Click on **SystemInfo** to display the data list screen of System Information.
- (2) Click on **Monitor Data** desired to monitor.
- (3) Click on **Offline Analyze**.



- The **System Information Screen** of Off-Line displays all connection information memorized by the connected Centralized Controller.

NOTE:

This covers the operation with the menu of the right-clicking of the mouse.
(Refer to 4.6.6 Right-clicking menu.)

- (4) Click on the address **Button** of the attributes to be displayed and the **Unit Information Display Column** is shown in the same way as when on-line. The **Function Selection Buttons** cannot be used.
- (5) "Menu Bar"
Return, **Print**, **Option** and **Help** are displayed on the menu bar.

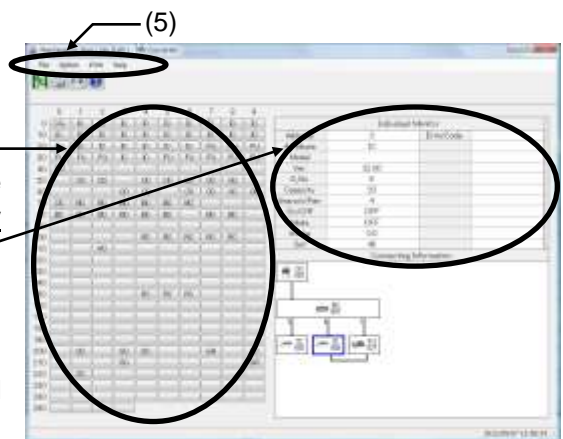

- Click on **Return** to end the system information. [Refer to (6)]
- Click on **Print** and an explanation "Print" and "Copy to Clipboard" will be displayed.
- Click on **Option** and then select "Display Mode" from the sub-menu.

To switch the display mode.[Refer to 3.6 Display Mode Change]

- Click on **Help** and an explanation "Terminology" and "Operation Method" will be displayed.
[Refer to 3.7.1 Connecting Information of outdoor units 3.7.1.2 (2) "Menu Bar"]
- (6) Click on **Return** on the menu bar to end system information.

4.5 Monitoring of Pre-error Data

4.5.1 Off-Line Analyzing

- (1) Click on **Pre-Error** to display the data list screen of Pre-error.
- (2) Click on **Monitor Data** desired to monitor.
- (3) Click on **Offline Analyze**.

NOTE:
This covers the operation with the menu of the right-clicking of the mouse.
(Refer to 4.6.6 Right-clicking menu.)



- (4) On the Pre-error Data screen, the operation status data immediately before generating error will be displayed in a unit of minute. Each figure on the upper column indicates a number of minute before generating an error respectively. The change of the display content is performed with Up/down, left/right scroll bar. The number of displayed items and that of the stored data (per minute) differ depending on the selected item.

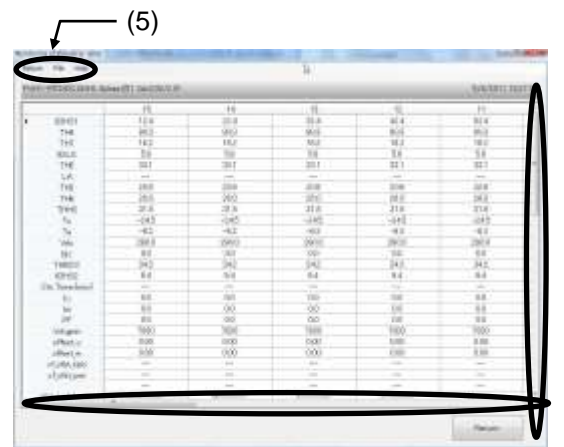

Outdoor Unit

- (5) "Menu Bar"
Return, **Text convert** of **file** and **Help** are displayed on the menu bar.

- Click on **Return** to end the Monitor before error occurred screen.[Refer to (6)]
- Clicking **Text convert** of **file** prepares a text file of the Before error occurred data being displayed.
- Click on **Help** and an explanation "Terminology" and "Operation Method" will be displayed.
[Refer to 3.7 Connecting Information 3.7.2 (2)"Menu Bar"]

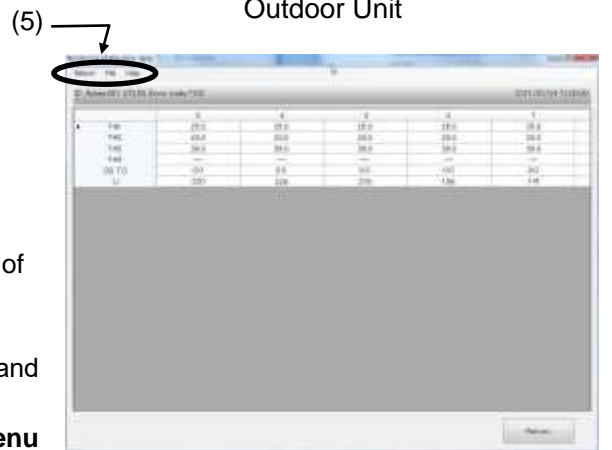

Indoor Unit

- (6) Click on **Return** on the menu bar to end the data list screen of **Pre-error Data**.

4.6 Compressor operating data monitor

4.6.1 Off-Line Analyzing

- (1) Click **[View]** of the menubar on the **[Off-Line Main]** screen, and click **[Compressor operating data monitor]** of the submenu to monitor the outdoor unit data. click **[Monitoring operation data of compressor for chiller]** of the submenu to monitor the chiller unit data. **[Compressor operating data monitor list]** screen is displayed.



- (2) When the line of data that wants to confirm the monitor result is clicked from **[Compressor operating data monitor list]** screen, and **[Display]** button is clicked, the monitor result is displayed on **[Compressor operating data monitor]** screen.

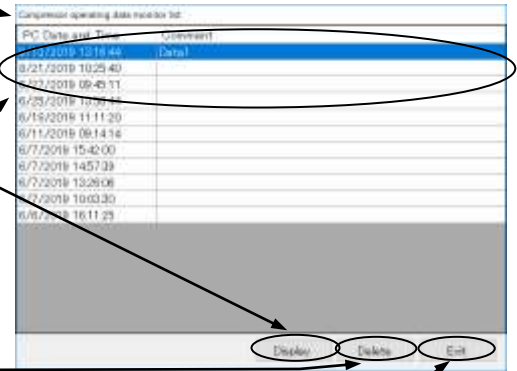

When the line of data clicked from the list screen, and **[Delete]** button is clicked, the selected data is deleted.

When **[Exit]** button is clicked, it returns to **[Off-Line Main]** screen.

- (3) To close **[Compressor operating data monitor]** screen, **[Close]** button is clicked. It returns to **[Compressor operating data monitor list]** screen.

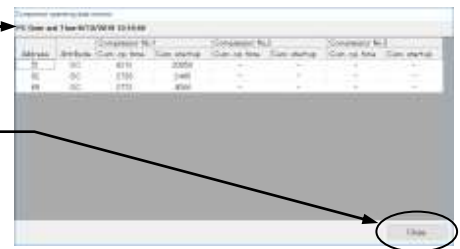

NOTE:

When the units with only one or two compressor, the compressor operating time and startup monitor that doesn't exist is displayed as "-".

4.7 Function common for each screen (Filing operation)

* Clicking the button of “Monitor Data”, “Monitor Date”, “Last Updated” and “Others” at the upper column allows to sort the displayed data.

* The right-clicking operation of the mouse covers the operation of each file also. For detail, refer to the item 4.7.6 Right-click menu.

4.7.1 Delete Data

- (1) Clicking either , or to display Data list screen containing the file desired to edit.
- (2) Click on **Monitor Data** desired to delete.
- (3) Click on . Then the screen to confirm the selected monitor data will appear. Clicking on deletes the data. Clicking on returns to Data list screen.



NOTE:

Selecting monitor data collectively enables to execute batch deletion.

This operation may be performed in the similar way of the file selection of Windows explorer (shift,ctrl).

4.7.2 Export

- (1) Clicking either , or to display Data list screen containing the file desired to edit.
- (2) Click on **Monitor Data** desired to output.
- (3) Click on .



- (4) The “Export” screen is displayed. Enter **Destination folder** and **Destination file name**, and then select **Run**. The data is exported to the specified destination folder

NOTE:

The extension of the exported file is .MTDZ

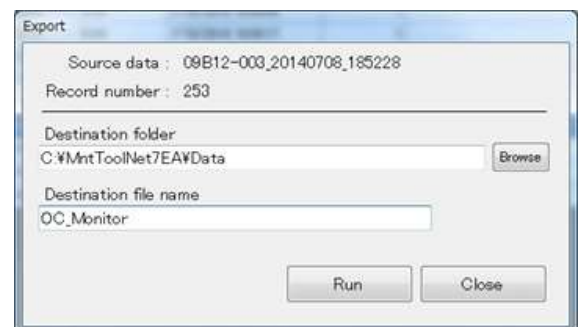

- (5) When one day or more of operation data is selected, you must select the data interval. Select the **[Data interval]** to export, and then select **[Run]**. Select **[Excute batch Output]** to export all of the data.

NOTE:

When you click **[Run]**, an export file for each selected data interval is individually output. The extension of the exported file is .MTDZ.

When you click **[Excute batch Output]**, the data for all of the data intervals is output in a single file. The extension of the exported file is .MTPZ.

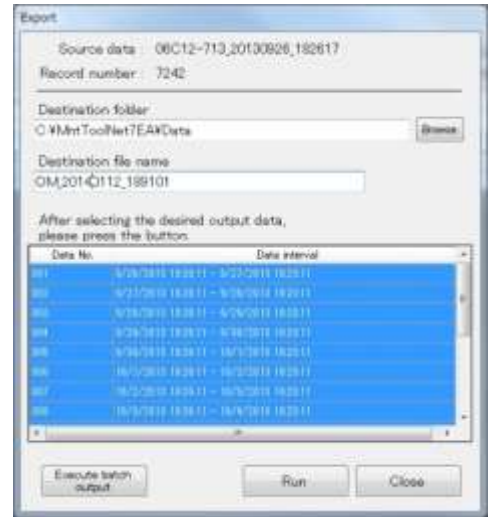

4.7.3 Import

- (1) Clicking either **Monitor**, **SystemInfo** or **Pre-Error** to display Data list screen containing the file desired to edit.

- (2) Click on **import**. The screen to read a file will be displayed. **Open** reading folder, input the file name and click on.

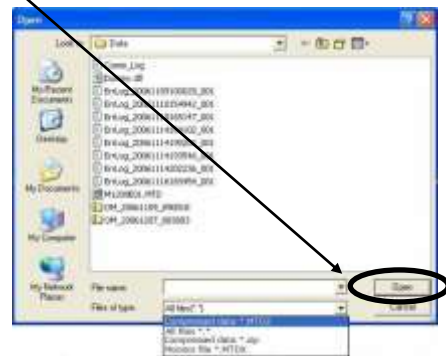

- (3) A progress bar is displayed while importing. Click **[Stop]** to stop the import process.

NOTE:

- Files with the following file extensions can be imported.
- Monitor file *.MTDZ,MTDX,MTPZ
 - Compressed data *.zip

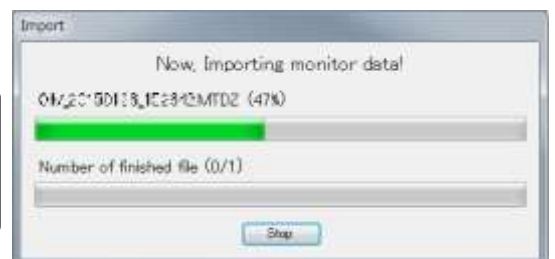

■ About the operation data collection function

Some outdoor units are equipped with functions of collecting and recording the unit operation data in the flash memory on the control board. The data recorded in the flash memory can be saved in the USB memory stick and checked from the Maintenance Tool.

■ About the data saved in the USB memory stick

In the USB memory stick, a folder MNT*** is created, and three files (data***.MT, inf***.MT, and etc***.MT) are saved in the folder.

*** is a serial number from 000 to 100.

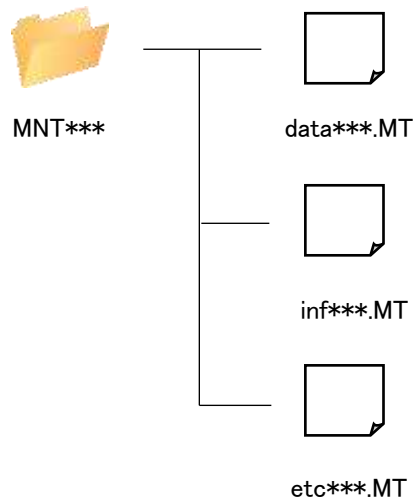

■ About checking the data

The data saved in the USB memory stick can be checked by importing one of the three files (data***.MT, inf***.MT, and etc***.MT) on the Maintenance Tool to add new data on the offline analysis screen. The file with the cumulative compressor operation time, error history, and outdoor unit dip switch setting data can be output.

4.7.4 Text Convert

- (1) Clicking to display Data list screen containing the file desired to edit.
(Text conversion can also be adapted to the Pre-error data. For the converting method, refer to 4.5.1(5).)

- (2) Click on **[Monitor Data]** desired to convert into text format.

- (3) Click on .
The screen to confirm the selected monitor data.
Clicking on provides text conversion processing and then a file name will be displayed.
[Refer to 5.4 Text Convert Data]



In the case of Operation Monitor, clicking displays Data Transfer Screen prompting you to select the object and method of the conversion.

- (a) Click on **[units]**.
Set the **[Sampling Time]** between 1-min and 10-min.
- (b) Click on .
"Converting! Please wait for a moment." Will be appeared, then a file name will be displayed.

[Refer to 5.4 Text Convert Data]

- (c) Click on to transfer the data of all units.
- (d) Click on to end the **Data Transfer Screen**.

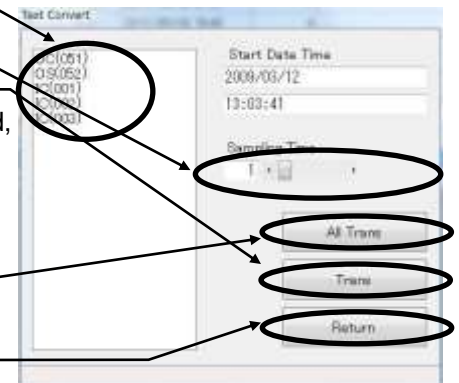

* During processing operation, the progress ratio will be displayed.

NOTE:

You can convert multiple files to text file at the same time by selecting multiple **[Monitor data]** and then clicking **[Text Convert]**.

4.7.5 Monitor Data information Edit

- Changing the name of monitor data
Clicking the Edit of the menu bar while focussing the monitor data name on the Monitor Data of which name is desired to be changed on the Screen listing each data will display the editing screen.
On this screen, the name of Monitor Data or other relevant information can be edited.

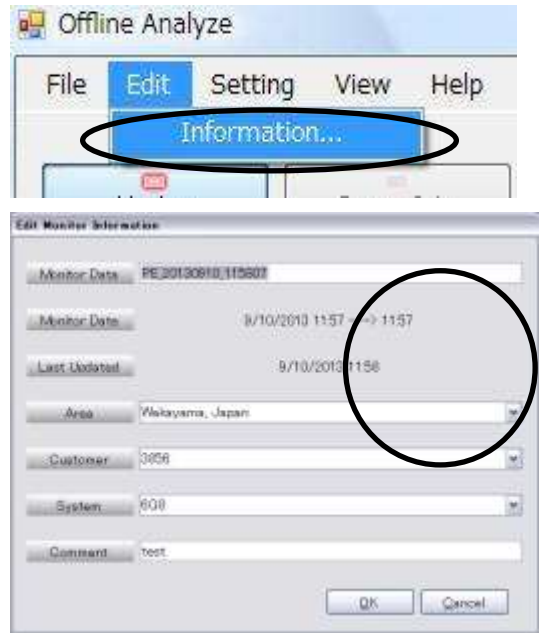

4.7.6 Right-clicking menu

- Right-clicking menu
Clicking the right button of the mouse on [Monitor data] displays the pop-up menu as shown on the right screen. The items that can be set are same as that of the function button on the screen listing each data.
(Some function is unable to operate partially.)
Use them in accordance with your applications.

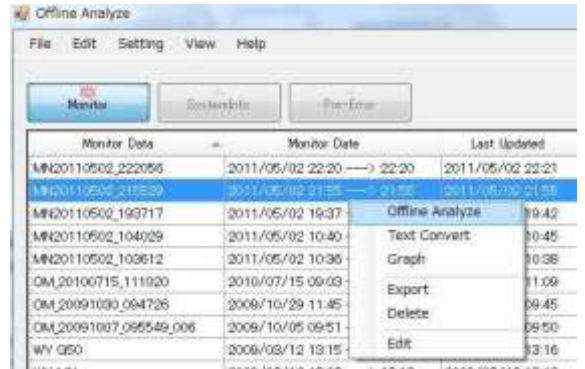

4.7.7 Malfunction Log Data

- Click **[View]** of the menubar on the **[Off-Line Main]** screen, and click **[Malfunction Log Data]** of the submenu.
The folder of data file is displayed by the Explorer.

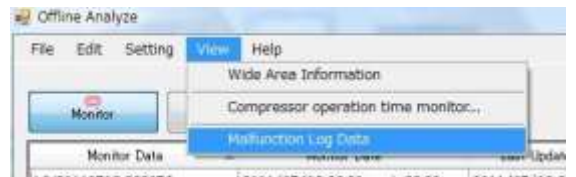

4.8 Offline Analyze on Wide area access mode

4.8.1 Off-Line Analyzing

The function of the offline mode is mostly equals that of the normal mode, however, the following function is provided additionally.

- 1) Display of monitored name objective for data collection.
 - The [AREA name], [Customer name] and [Air conditioning system name] are shown for each data obtained.
 - Setting the cursor to the data provides the pop-up display of the [AREA name], [Customer name] and [Air conditioning system name] of the data.

In order not to show the POP-UP display, click the View of the menu bar and remove the check mark of the [Show Wide Area Info.] on the sub-menu.

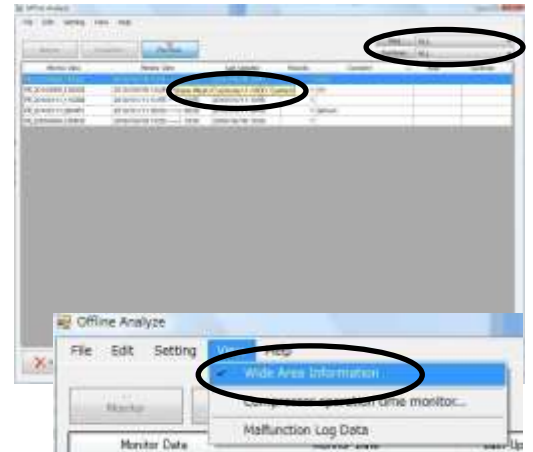

- 2) Display of extracted data.
 - By selecting [AREA name] and [Customer name], the relevant data only can be displayed.



As the other function and operation are same as that under the normal mode, please refer to Chapters 4.3 – 4.7.

NOTE:

Both the data obtained by online under normal mode and that under wide area access mode can be displayed commonly under both offline modes.

4.9 Offline Analyze on Initial settings of AHC

4.9.1 Off-Line Analyzing

Initialize AHC settings in OFFLINE mode.

- (1) From the [**Option**] menu bar, select [**AHC Initialize Setting**] on the submenu.

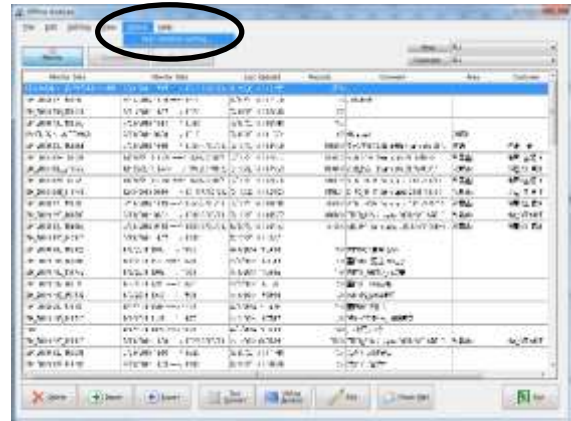

- (2) The [**AHC Initializing Setting**] screen opens.



- (3) The radio buttons can be used to toggle settings on the [**Remote I/O setting**] tab. Select [**Ver.2 (Flexible)**] to edit settings for an AHC ADAPTER that is Ver. 2.00 or later AND when DipSW103-3 is set to OFF. Otherwise, select [**Ver.1 (Fixed)**]. The steps to follow to configure settings are the same as in ONLINE mode. Refer to [3.18.2 Initial Settings of AHC] for further details.

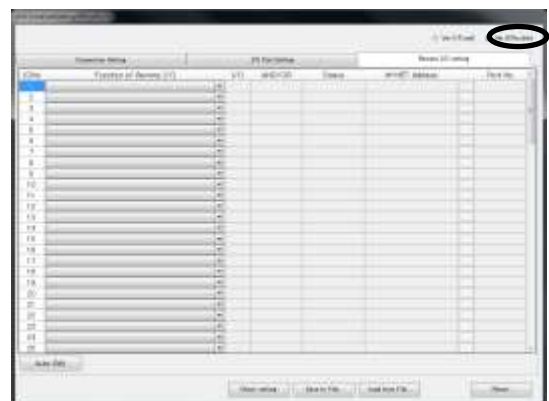
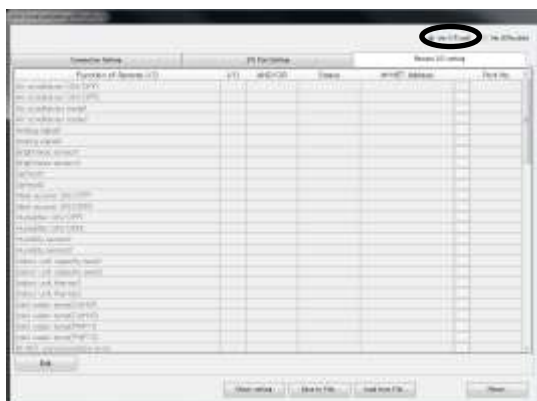

NOTE:

- Configuring the initial settings of AHC and creating a settings file using [**Save to file**] in advance in OFFLINE mode will enable settings to be configured more smoothly on-site.

5.1 System Information Data

When the system information data saved in the database in “**3.4 Main Screen (2)**” is exported in “**4.7.2 Export**”, exported data is saved in

C:¥MntToolNETEA¥Data. (Default setting. Can be changed.)

The exported file is a compressed archive with the file extension MTDZ.

- The following is an explanation of the file name

SI_20040315_181026.MTDZ

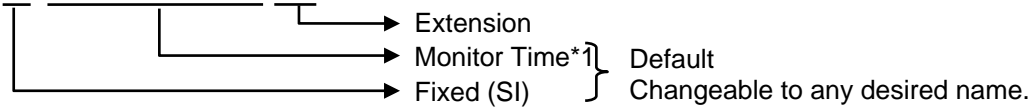

*1 Monitor Time

Monitor starting time : YYYYMMDD_hhmmss format

5.2 Operating Status Monitor Data

When the operation status monitor data saved in the database automatically in “**3.7 Operation Monitor**” is exported in “**4.7.2 Export**”, exported data is saved in

C:¥MntToolNETEA¥Data. (Default setting. Can be changed.)

The exported file is a compressed archive with the file extension MTDZ or MTPZ.

- The following is an explanation of the file name(**Operating Status Monitor Data** has been automatically stored at the on-line monitoring.)

OM_20040315_181026.MTDZ (or MTPZ)

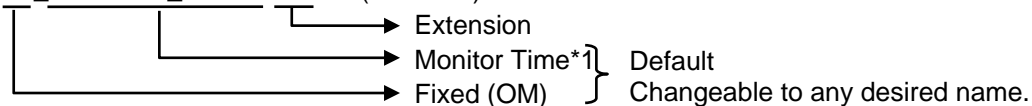

*1 Monitor Time

Monitor starting time : YYYYMMDD_hhmmss format

5.3 Pre-error Data

When the pre-error data saved in the database in “3.11.1.2 Monitoring of Pre-error Data” is exported in “4.7.2 Export”, exported data is saved in

C:¥MntToolNETEA¥Data. (Default setting. Can be changed.)

The exported file is a compressed archive with the file extension MTDZ.

- The following is an explanation of the file name(**Pre-error Data** has been automatically stored at the on-line monitoring.)

PE_20040315_181026.MTDZ

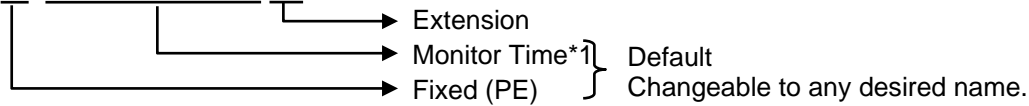

*1 Monitor Time

Monitor starting time : YYYYMMDD_hhmmss format

5.4 Text Convert Data

The data saved in Section “4.7.4 Text Convert” is stored in
C:¥MntToolNETEA¥Data

- The following is an explanation of the file name

OM_20040315_181026_(001).CSV

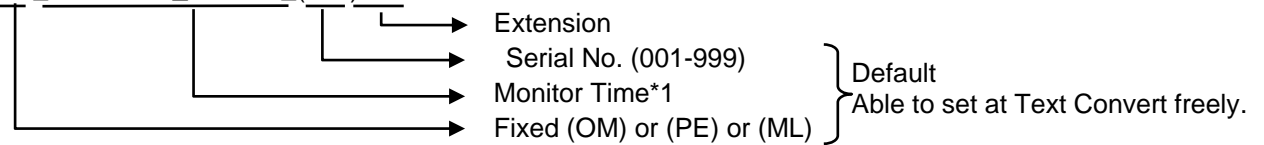

*1 Monitor Time

Monitor starting time : YYYYMMDD_hhmmss format

- * For the data obtained before Ver4.04 via MN Converter, “MN”-“PC host name” will be displayed at the former part of the data.

5.5 Compressor Operating Data

The data saved in Section “3.17 Compressor operating data monitor” is stored in **C:¥MntToolINETEA¥Data**

- The following is an explanation of the file name

Outdoor units

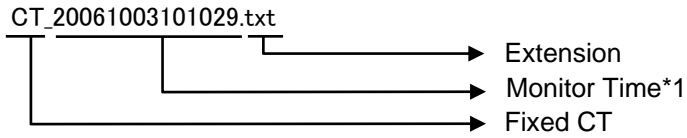

Chillers

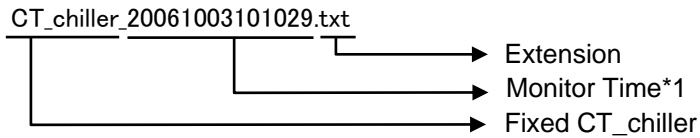

*1 **Monitor Time**

Monitor time : YYYYMMDD_hhmmss format

5.6 Remote error notification report log Data

The data saved in Section “3.14.5.3 Saving the Report log in CSV format” is stored in **C:¥MntToolINETEA¥Data**

- The following is an explanation of the file name

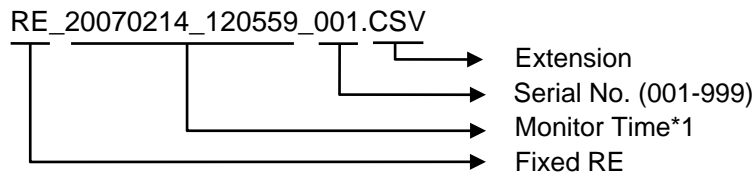

*1 **Monitor Time**

Monitor time : YYYYMMDD_hhmmss format

5.7 DIDO Controller Monitor Data

The data saved in Section “3.15.1 Setting and Monitoring DIDO Controllers (66DC)” is stored in **C:¥MntToolINETEA¥Data**

- The following is an explanation of the file name

(1) Monitoring input/output status on DIDO Controllers (66DC) (Section “3.15.1.2”)

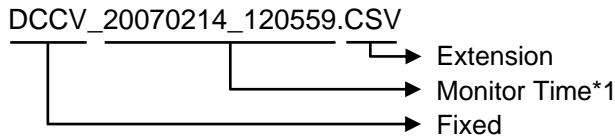

(2) Monitoring Dip switch setting of DIDO Controllers (Section “3.15.1.4”)

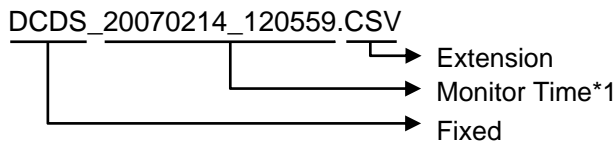

*1 **Monitor Time**

Monitor time: YYYYMMDD_hhmmss format

5.8 AI Controller Monitor Data

The data saved in Section “3.15.2 Setting and Monitoring AI Controllers (63MC)” is stored in **C:¥MntToolINETEA¥Data**

- The following is an explanation of the file name

(1) Monitoring measurement value on AI Controllers (63MC) (Section “3.15.2.1”)

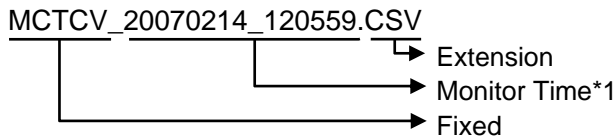

(2) Monitoring Dip switch setting of AI Controllers (Section “3.15.2.3”)

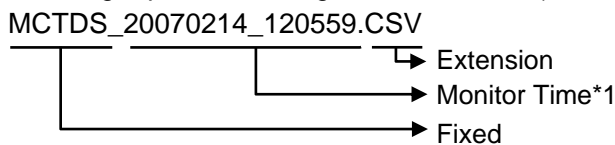

(3) Monitoring of the correction value for Pt100 detection (Section “3.15.2.4”)

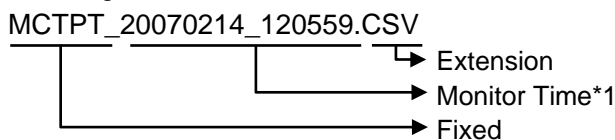

(4) Measured value history (Section “3.14.2.5”)

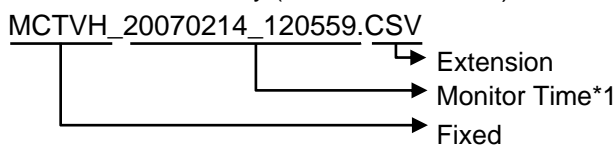

(5) Out-of-limit alarm history (Section “3.15.2.6”)

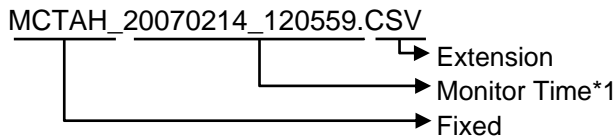

(6) Measurement category setting history (Section “3.15.2.7”)

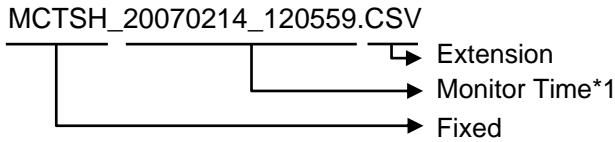

*1 **Monitor Time**

Monitor time: YYYYMMDD_hhmmss format

5.9 PI Controller Monitor Data

The data saved in Section “3.15. Monitoring PI Controllers (60MC)” is stored in **C:¥MntToolINETEA¥Data**

- The following is an explanation of the file name

(1) PI Controller (60MC) measurement value Monitor (current value) (Section “3.15.3.1”)

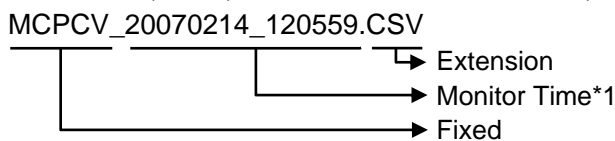

(2) PI Controller (60MC) measurement value Monitor (cumulative value) (Section “3.15.3.2”)

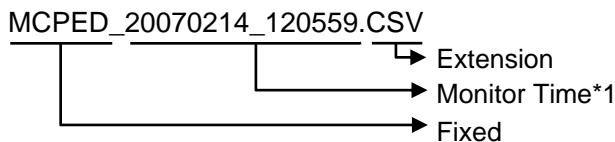

(3) PI Controller (60MC) measurement value Monitor (settlement date) (Section “3.15.3.3”)

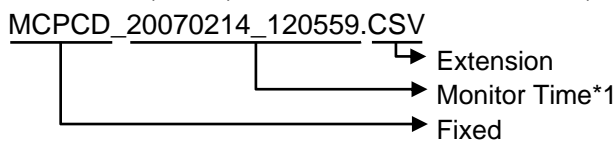

(4) Charge time zone setting monitor (Section “3.15.3.5”)

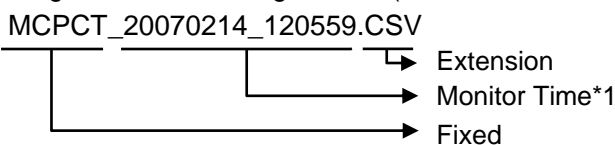

(5) Monitoring Dip switch setting of PI Controllers (Section “3.15.3.6”)

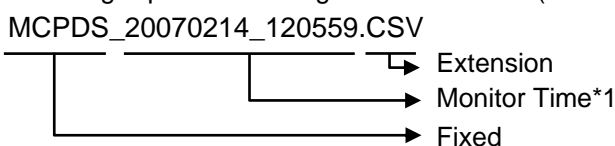

(6) Power failure/restoration history (Section “3.15.3.7”)

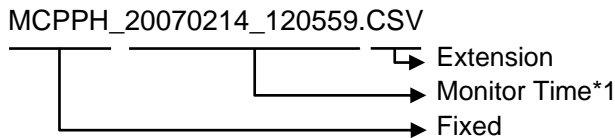

(7) Pulse unit (weight) change history (Section “3.15.3.8”)

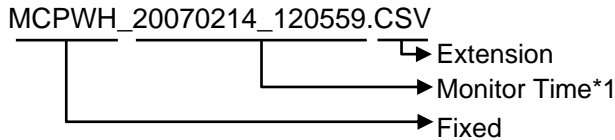

*1 **Monitor Time**

Monitor time: YYYYMMDD_hhmmss format

5.10 DIDO/AI Controller interlock control Data

The data saved in Section “3.15.4 Interlock control settings on DIDO Controllers (66DC)” and “3.15.5 Interlock control settings on AI Controllers (63MC)” is stored in **C:¥MntToolINETEA¥Data**

- The following is an explanation of the file name

(1) Saving the interlock control settings on DIDO Controllers (66DC) in CSV format (Section “3.15.4.4”)

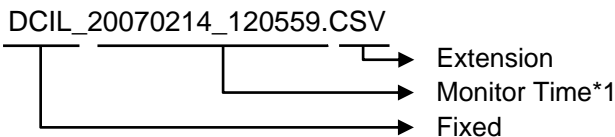

(2) Saving the interlock control settings on AI Controllers (63MC) in CSV format (Section “3.15.5.4”)

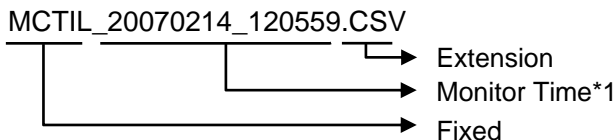

(3) DIDO controller interlock operation history (Section “3.15.4.5”)

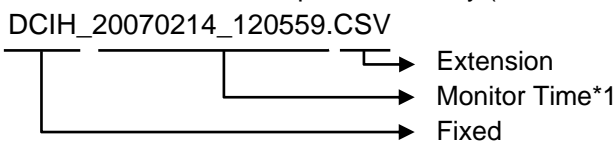

(4) AI Controller interlock operation history(Section “3.15.5.5”)

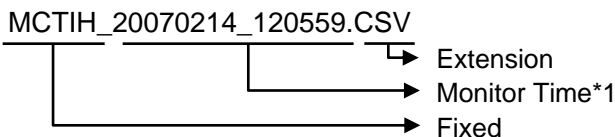

*1 **Monitor Time**

Monitor time: YYYYMMDD_hhmmss format

Trouble When Installing or Starting

Trouble	Cause	Repair
Cannot install.	Install CD-ROM not properly positioned. A local disk (It's C-Drive) is setting a compression option.	Properly position Install CD-ROM. Release compression option of a local disk, and install the Maintenance Tool again.
Installation of the USB driver of CMS-MNG-E has failed.	Driver installation may fail when the core isolation function is enabled in the Windows security settings to protect devices.	Disable the core isolation function in the Windows security settings, and try installing the driver again.
Cannot start application.	Insufficient memory. OS is not an English version. A local disk (It's C-Drive) is setting a compression option.	End other applications. Regional options setup, changing into English area form. Or after changing date separator into [/], time separator into [:], and a decimal point mark is changed into [.] it tries. (Refer to 1.2.1 *1) Release compression option of a local disk, and install the Maintenance Tool again.
The message of "Can't Connect to Centralized Controller" is displayed at on-line starting.	The IP address of Centralized Controller or PC is incorrect.	Input the correct address.
	LAN cable is not connected.	Connect securely LAN cable between Centralized Controller/HUB/PC.
The message of "Maintenance Tool can't connect to old version G-50A! Use G-50A upper version2.40!" is displayed at the on-line starting.	The S/W version of G-50A is older than Ver2.40.	The Maintenance Tool can not be connected to the older version of G-50A than Ver2.40. Use the new version G-50A. (Recommended Ver2.50 or more) To use the E-mail connection mode, the version of G-50A should be above 2.60.
The message "M-Net interface board not connected" appears.	-RS-232C cable and MN converter are not connected. -A straight type RS-232C cable is being used.	A cross type RS-232C cable is being used. Make sure MN converter and PC are properly connected. (Refer to Operator's Manual for the MN converter.)
	MN converter is not turned on.	Connect the MN converter and the air conditioning unit to the M-Net transmission line. (Refer to the Operator's Manual for the MN Converter)
A message of " Monitor data size is very large!! Please, delete old monitor data!!" is displayed at starting.	The memory capacity to store data is insufficient.	Move to Offline Screen, and delete unnecessary data.
A message of " Maintenance Tool can't connect to this Centralized Controller! Because, this Centralized Controller is not licensed!!" is displayed at starting under the online mode.	The license registration has not been done for Centralized Controller.	Purchase the license No., and register the license for Centralized Controller.
A message of " The term of validity of the installed version went out.!!" Is displayed at starting. Maintenance Tool does not start.	The term of validity of the installed version went out.	It upgrades. Please upgrade periodically

Trouble	Cause	Repair
A message of "Communication conversion application does not exist " is displayed at starting online mode.	Application software for P/M-series does not exist.	Reinstall the latest maintenance tool.
A message of "Rewriting software for USB/Serial conversion cable does not exist.Please check the manual for M&P-series" is displayed at starting online mode.	FT_PROG is not installed.	Install FT_PROG. *Refer to 1.3.1 (5)
A message of "USB/Serial conversion cable is not connected" is displayed at starting online mode.	USB /Serial conversion cable is not connected.	Operate the maintenance tool with USB / Serial conversion cable connected.
A message of " Model DataBase does not exist" is displayed at starting online mode.	Software required for the operation of the maintenance tool does not exist	Reinstall the latest maintenance tool.
A message of " Multiple cables are connected" is displayed at starting online mode.	Multiple USB cables (FTDI chip built-in) are connected to the PC.	Operate the maintenance tool with only the USB/Serial conversion cable.
A message that it is necessary to install .net Ver 4 or later is displayed at starting online mode.	.NET Framework 4.0 is not installed.	Install .NET Framework 4.0 or more.
A message that it is missing vcruntime140 is displayed at starting online mode.	Visual C++ Redistributable is not installed.	Install Visual C++ Redistributable. *Refer to 1.3.1 (5)
Display does not move from title screen to Operation monitor screen with P-series.	Air conditioning system power on timing is wrong.	Please turn on air conditioning system after connecting Maintenance tool. (Refer to 1.4.3.1 In case for local connection)

Trouble with Main Screen

Trouble	Cause	Repair
Cannot select function selection buttons.	Collecting data about individual units using manual search. (Unit is communicating.)	Can be used when communication with all the units selected by manual search have completed communication.
A[**]appears in the unit address button for an existing unit.	-No response from that unit. -Attributes cannot be known due to communication error.	Wait a moment and then click on the address button for the same unit again.
A[**]appears in the unit address button for a unit that does not exist.	Interference caused an non-existing unit to appear.	Wait a moment and then click on the address button for the same unit again. The[**] display will disappear.
A[??]appears in the address button.	There is a unit that is not compatible with the Maintenance Tool.	Refer to the explanation on terminology in help. If there is no explanation, the unit is not a compatible type.
Address searching takes 3 minutes or more per set. (Centralized Controller connection)	The port required for communication is being protected by the Firewall checking function of Windows or anti-virus software.	In this case, the communication transmitted from Centralized Controller may not partially be received. Please remove the check mark on the Firewall function of the necessary port. (For detail, please refer to "6. How to change setting of Firewall".) (If the version of G-50A is more than 2.50, only [IC] can be searched, even if it uses FIREWALL. However, [OC] reference cannot be performed. Moreover, since other functions cannot operate normally, please be sure to remove a check.)
	When a Maintenance Tool is not ended normally, Centralized Controller will be in a data resending state, and LAN communication will increase.	In this case, please perform "Stop mail communication" of 3.4 (2), and start a Maintenance Tool again after waiting about 15 minutes.
	The version of G-50A is old.	A recommendation version is 2.50 or more.

Connecting information Trouble

Trouble	Cause	Repair
Cannot switch to connection information screen.	A unit other than an outdoor unit (OC) has been selected.	Refer to 3.6.1
The connection data display does not appear when the operating system SC is clicked.	An operating SC other than remote control has been clicked.	Click on remote control. Monitoring of connection data cannot be done from operating SC other than remote control.

Operation Monitor Trouble

Trouble	Cause	Repair
The monitor display screen on the operation monitor has red characters.	Because of the increased re-transmission process work due to abundant communication noise, data may not be monitored fully within the rated cycle.	Please take a countermeasure against the communication noise source in this case.
All of the characters on the monitor display for some units are red.	There is no answer from the unit.(Cannot communicate with the unit.)	Error with unit. Refer to the service handbook for that unit.
The message of " Centralized Controller can't Connect to SMTP Server ! or Centralized Controller Date Setting is wrong !! Continue ?" is displayed at remote monitor setting.	The dial-up router is not connected. Or connected but incorrectly.	By referring to Instruction Manual of Dial-up router, connect or set correctly.
	The default gateway of Centralized Controller is not set.	Set correctly by using the Centralized Controller initial setting tool. (When Centralized Controller, please set it from initialization WEB.) (Refer to Instruction Manual of Centralized Controller.)
	The incorrect display of the receiver address is pointed out by SMTP.	Set the correct mailing address.
	The Monitor Finish Date is older than the current date/time of Centralized Controller.	Set the monitor finish date correctly. (However when connecting to Centralized Controller in a region with a time differential, set it by considering the time in that place.)
A message of " Monitor data size is very large!! Please, delete old monitor data!!" is displayed during collecting data.	The memory capacity to store data is insufficient.	Move to Offline Screen, and delete unnecessary data.
Data becomes a red display and the "-" display.	Since data cannot receive normally. - There is too much number of a monitor. - Data transforms itself by a noise.	- Reduce the number of a monitor. - Cope with noise generating origin. * Also when returning from a graph screen to an operation screen, it may become a red display and the "-" display, but it is normal.

Malfunction Log Trouble

Trouble	Cause	Repair
Cannot clear malfunction log	The unit is not compatible with malfunction log clear.	The malfunction log cannot be cleared.
There is an error code, but the contents of the error are not displayed	This is a newly added error code and is not compatible with the Maintenance Tool.	Refer to the service handbook for that unit.

Operation Monitor Mail Communication Mode Trouble

Trouble	Cause	Repair
<p>Operation monitor mail cannot receive normally.</p>	<p>A mail address and SMTP server information were made a mistake in and set up by mail communication setup.</p>	<p>Please set up the right information again after performing "Stop mail communication" of 3.4 (2).</p>
	<p>The mail address a contract of is not made with a provider was set as [FROM: Mail Address]. (When using dialup)</p>	<p>Please set the regular mail address a contract of is made with the provider to [FROM: Mail Address].</p>
	<p>The mail address of recipient (To:) is not an address only for Maintenance Tool. (The mail address used usually is set up. In this case, once other mail software receives mail, operation data mail will be deleted from a mail server.)</p>	<p>The mail address of recipient (To:) acquires and sets up the address only for Maintenance Tool.</p>
<p>The analysis screen of the operation monitor data (which carried out mail acquisition by OFFLINE) is not displayed.</p>	<p>The system configuration information acquired from Centralized Controller immediately after a mail communication setup was not acquired normally.</p>	<p>Please delete the corresponding data. Text conversion can be carried out and data can be outputted.</p>
	<p>Mail communication mode was set up from the Maintenance Tool of a remote place, and the mail address of recipient (To:) was set as another addressing to a Maintenance Tool of a remote place. (System configuration information mail is transmitted from Centralized Controller immediately after a mail communication setup. However, the Maintenance Tool by the side of a setup is using dial-up service, and mail transmission cannot be performed. Consequently, since the Maintenance Tool with which mail is transmitted cannot acquire system configuration information mail, even if it receives after that operation monitor data mail, it does not indicate by normal.</p>	<p>When mail communication mode is set up from the Maintenance Tool of a remote place, mail acquisition of operation data can be performed only with the Maintenance Tool which set up. Please make a set the mail address of a Maintenance Tool which set mail communication mode to the mail address of recipient (To:).</p>

Free contact of indoor unit Trouble

Trouble	Cause	Repair
A menu cannot be chosen and cannot be started.	The version of G-50A is old.	A recommendation version is 2.60 or more.

Remote error notification Trouble

Trouble	Cause	Repair
A menu cannot be chosen and cannot be started.	The MN Converter model is not CMS-MNG-E.	Use the CMS-MNG-E MN Converter model.
When Maintenance Tool is connected to the MN Converter (CMS-MNG-E) via RS-232C, a message of " Cannot communicate with MN converter." is displayed at starting. Maintenance Tool does not start.	The MN converter (CMS-MNG-E) mode is the error notification mode.	Connect to the MN Converter (CMS-MNG-E) via USB.

Setting and Monitoring DIDO/AI/PI Controllers Trouble

Trouble	Cause	Repair
The pulse unit (weight) cannot be set on the PI Controller.	The PI Controller can be used only for monitoring.	Make the settings for the PI Controller on Centralized Controller Web Browser or TG-2000A.
An error occurs when the limit alarm value is set on the AI controller (63MC) setting screen on the AI Controller.	The values exceeding the upper/lower limit of the measurement range are set.	Set the values between the upper and lower limit of the measurement range.
[DIDO/AI interlock setting] in the sub menu is inactive.	The interlock setting is not set to enabled on the Interlock control option screen .	[Option] in the menu bar and select [DIDO/AI/PI] , and select [Interlock control option] in the sub menu. Read the agreement on the Interlock control option screen , and agree.
An error occurs when the password is entered to accept the agreement on the Interlock control option screen .	The entered password is incorrect.	Ask the administrator for the password used on the Interlock control option screen .
An error occurs when the upper/lower thresholds for the interlock operation condition are set on the AI controller (63MC) interlock control setting screen .	The values exceeding the upper/lower limit of the measurement range are set.	Set the upper/lower thresholds for the interlock operation condition between the upper and the lower limit values of the measurement range.
An error occurs when the interlock control setting is made on the DIDO controller (66DC) /AI controller (63MC) interlock control setting screen .	The interlock target unit that has the set address does not exist.	Set the correct unit address of the interlock target.
The interlock control is not performed when the interlock control setting is made.	The set address of the interlock target unit is incorrect., or the address of the different unit is set.	Set the correct unit address of the interlock target.
	An emergency stop is made when the interlock control is set to "Prohibited" when an emergency stop is made with Centralized Controller.	After the emergency stop is reset, check that the interlock control is performed properly.
	A communication error occurs when the interlock control is set to "Prohibited" when a communication error is occurring with Centralized Controller.	After the communication error is reset, check that the interlock control is performed properly.
Two or more interlock control operations with the AI Controller are being performed simultaneously.	The set input condition and the set range overlap with those that have been set for other interlock No.	Check that the set input condition and the set range do not overlap with those that have been set for other interlock No. There is an exception when two or more interlock control operations are simultaneously performed.
	Differentials are set for some interlock operation No., whereas not for some, or the set differentials are different.	To make the differential valid, make the differentials of all the channels the same.
The attribute (each address) searched by auto or manual search cannot be set.	The wrong sub menu is selected in [Option] in the menu bar.	Select the correct setting the sub menu, and set the attribute (each address).
	After the attribute is displayed, the unit to be connected is changed without changing the address.	Click [File] and select [Return] to shutdown and restart the Maintenance Tool. Try the auto/manual search again.
The message "***** monitoring failed." appears.	The power of the unit is turned off, or the M-NET transmission line or the MN converter is not connected properly.	Turn on the power of the unit, and reconnect the M-NET transmission line or the MN converter.
The upper/lower detection/cancellation values are not updated when [Monitor update] is clicked on the AI controller (63MC) measurement value monitoring screen .	When the setting change is made on Centralized Controller Web Browser, the upper/lower detection/cancellation values are not updated. Only the measurement value and the alarm status are updated.	Click [Close] to end the AI controller (63MC) measurement value monitoring screen , and open the screen again.

Off-Line Monitor Trouble

Trouble	Cause	Repair
The message of "Timeout Can't connect to Mailserver." is displayed.	The setting of IP address of POP server is incorrect.	Set the correct IP address with Mail Server Setting.
	The setting of the IP address of PC is incorrect.	Set the IP address of PC correctly.
The message of "Invalid Parameter!" is displayed.	The POP server is not set yet.	Set POP server.
The message of "Can't Connect to mail sever!" is displayed.	The LAN cable is not connected correctly.	Connect LAN cable securely.
	The IP address setting of POP server is not correct.	Set the correct IP address with Mail Server Setting.
The message of "POP Authention Error" is displayed.	The setting of the user and password of POP server is not correct.	Set correctly with Mail Server Setting.
A message of " Monitor data size is very large!! Please, delete old monitor data!!" is displayed during collecting the mail of operation data.	The memory capacity to store data is insufficient.	Move to Offline Screen, and delete unnecessary data.
A message of " Now finalizing Maintenance Tool !!" is displayed at finishing Offline, and the screen does not finish.	The internal data is under arrangement at finishing the Maintenance Tool.	Offline Screen will automatically be finished after completing this process. Please wait a while.
Data cannot be imported.	It was going to import the data acquired by "Maintenance Tool (Ver.3.**)".	The data obtained by Ver.4.** has no compatibility with that obtained by Ver.3.**.
A message of " The file name is incorrect. --- " is displayed. Data cannot be imported.	It contains characters unable to be fetched in (such as ["or"] and the like).	Please delete such special characters in the file name.
In processing for the time searching or text convert of the operation status monitor, "Date or Time is wrong" is displayed without executing the processing.	The information inherent in a district (language) will be added on the column of Date and Time depending on the PC (OS) of the district. However, such information inherent in the district can not be read by the Maintenance Tool.	- Change the setting of the OS to that in English for use. - Execute processing after deleting the information (characters) inherent in the district to be added on the column of Date and Time.
"This archive file was broken." appears when importing.	The ZIP archive selected for importing may be broken.	Double-click the applicable file and check that the file is recognized as a ZIP archive. Archives acquired from media or through email is sometimes broken. In such a case, reacquire the archive.
"As for the data with path, the import is not done." appears when importing.	Multiple files are included in the ZIP archive selected for import.	Extract files from the ZIP archive to a folder and then select the files to import when importing.
"Since two or more files are compressed, it cannot import." appears when importing.	Archives created in a format that includes a path cannot be imported.	Extract files from the ZIP archive to a folder and import them.

Unit trouble when connecting Maintenance tool

Trouble	Cause	Repair
Communication error ED/ 0403 occurs with P-series.	Air conditioning system power on timing is wrong.	Please turn on air conditioning system after connecting Maintenance tool. (Refer to 1.4.3.1 In case for local connection)

Models and terms not explained in this chapter are explained in the term explanations of the [Operation Status Monitor] screen and [Refrigerant Circuit Diagram] screen.

See "3.8.2 Screen Functions and Operations" for details.

Main Screen Terminology

Mark	Meaning
Address	Address of selected unit
Attribute	Attribute of selected unit CG Control gateway TR Central controller RC Remote controller VR VAV remote controller MB Parallel interface MA M-net converter for K-control KA K-control converter for M-net AN Multi panel controller GR Group remote controller AR Air handling remote controller FR Fan coil remote controller SC System controller IC Indoor unit LC Lossnay OC Outdoor unit (heat source unit) BC BC controller BS BC controller SE Remote sensor HB Hydro branch controller HS Sub-Hydro branch controller HU Hydro unit FU Fresh master AH Air handling unit FL Fan coil unit FA Filter unit IU ICE-Y sub controller CA CAV controller MC Measuring controller BU Booster Unit AU Water HEX Unit CE Hot Water Heat Pump Unit (MAIN) CL Hot Water Heat Pump Unit (SUB) AHC ... Advanced HVAC CONTROLLER
Model	Model of selected unit
Ver.	S/W version of selected unit
G_NO.	Group number
Capacity	Capacity of selected unit
UL-Model	UL-Model number of selected unit
Branch/pair	Branch or pair number
ON/OFF	Operation ON/OFF
Mode	Operation mode
Intake	Room temperature
Set	Set temperature
Err-CD	The newest error is displayed.

Connecting Information Monitor Terminology

Mark	Meaning
CG	Control gateway
TR	Central controller
RC	Remote controller
VR	Remote controller for VAV
MB	Parallel interface
MA	M-net converter for K-control
KA	K-control converter for M-net
AN	Multi panel controller
GR	Group remote controller
AR	Air handling remote controller
FR	Remote controller for fan coil
SC	System controller
IC	Indoor unit
LC	Lossnay
OC	Outdoor unit (heat source unit)
BC	BC controller
BS	BC controller
HB	Hydro branch controller
HS	Sub-Hydro branch controller
HU	Hydro unit
SE	Remote sensor
FU	Fresh master
AH	Air handling unit
FL	Fan coil unit
FA	Filter unit
IU	ICE-Y sub controller
CA	CAV controller
MC	Measuring controller
BU	Booster Unit
AU	Water HEX Unit

Monitoring of Pre-error data Terminology

Mark	Meaning
OC	Outdoor Unit
	Condensing unit ECO-V-X15/37/55VA
OS	Outdoor Sub Unit
IC	Multidensity Modbus I/F
CE/CL	CAHV-P500YA-HPB
	CAHV-P500YB-HPB
	CRHV-P600YA-HPB
	QAHV-N560YA-HPB
	QAHV-N560YA-KR
QAHV-N136TAU-HPB	
CH/CL	EACV-P900YA,EAHV-P900YA,EAHV-P900YA-H
HB	CMB-WP108V-G
	CMB-WP108/1016V-GA1
	CMB-WM108/1016V-AA
	CMB-WM350/500F-AA
HS	CMB-WP108/1016V-GB1
	CMB-WM108/1016V-AB
	CMB-WM108/1016V-BB
HU	CMH-WM250/350/500V-A
CC	RBH-P35NRA-Q-TWN/RBS-P20/202HRA-Q-TWN

Operation Status Monitor Terminology

Mark	UL/Non-UL	Model		
OC	UL	Y	PUHY-P72/96/108TGMU-A PUHY-P126/144TGMU-A PUHY-P168/192/204/216/234TGMU-A	
		R2	PURY-P72/96/108/126/144TGMU-A PURY-P168/192/204/216/234TGMU-A	
		WY	PQHY-P72/96TGMU-A	
		WR2	PQRY-P72/96TGMU-A	
		S	PUMY-P100/125/140YHM PUMY-P36/48NHMUR4 PUMY-P36/48NKMU PUMY-HP36/48NKMU PUMY-P60NKMU MXZ-8C48NA MXZ-4C36/5C42/8C48NAHZ MXZ-8C60NA-U1	
		Non-UL	Y	PUHY - 200/250YM* PUHY - 200/250YMF PU(H)Y-P200/250YMF-B,YMC PU(H)Y-200/250YMF-B,YMC PU(H)Y-200/250TM-(C) PU(H)Y-400/500YBM PU(H)Y-315YMC PUHY-400/500YMF-B,YMC PUHY-P400/500YMF-B,YMC PU(H)Y-P200/250YMF-C PUHY-P400/500YMF-C PUHY-400/500YMF-C PUD-P200/250YMF-C PU(H)Y-P200/250/315Y(R)EM-A PU(H)Y-P200/250/315YEM(*)-A PU(H)Y-200/250/315YEM(*)-A PUHY-P700/750/800YSGM-A PUHY-P200/250/300/350YGM-A PUHY-P400YGM-A PUHY-P450/500/550/600/650YGM-A PUHY-P450/500/550/600/650YMM-A PUHY-P400/650YSM-A PUHY-P450/500/550/600/650YCSM-A PUHY-P600YCSS-A PUHY-200/250/300/350/400/450/500YC-A PUHY-P200/250/300/350/400/450/500/550/600/650/700YC-A PUHY-P300/350/400YCSM-A PUHY-P450/500/550/600/650YMM(C)-A PUHY-P400/650YSM(C)-A PUHY-P450/500/550/600/650YCSM-A PUHY-P450/600YCSS-A
			WY	PQHY-P200/250YEM-A PQHY-P200/250YGM-A PQHY-P400/500YSGM-A
			R2	PURY-200/250YM PURY-200/250YMF-B PURY-P200/250YMF-B PURY-200/250YMF-C PURY-P200/250YMF-C PURY-P400/500YMF-C PURY-200/250YEM-A PURY-P200/250YEM-A PURY-80/100TMU PURY-P200/250/300/350/400YGM-A PURY-P450/500/550/600/650YGM-A
			WR2	PQRY-P200/250YMF-B PQRY-P200/250YMF-C PQRY-P200/250YGM-A PQRY-P400/500YSGM-A

Mark	UL/Non-UL	Model			
OC	Non-UL	S	PUMY		
			PUMY-P100/125/140V/YHM-A		
			PUMY-P100/125/140YHM-B		
			PUMY-P125/140V/YHMBR3		
			PUMY-P100/125/140YHMC-C		
			PUMY-SP100/125/140YHMC-SD		
			PUMY-P100/125/140VHMC-S		
			PUMY-SP100/125/140VHMC-SR		
			PUHZ-RP**HA		
			PUMY-P100V/YHMBR4		
			PUMY-P125/140V/YHMSR1		
			PUMY-P112/125/140V/YKM(E)		
			PUMY-P112/125/140V/YKM-A		
			PUMY-SP80V/YKMD-A(R1)		
			PUMY-SP100/125/140V/YKM		
			PUMY-CP100/125/140V/YKM		
			PUMY-P200/250YKMC-C		
			PUMY-P200/250YKM1-CN		
			PUMY-SP200/250YKM1-SD		
			PUMY-P200YKM		
			PUMY-P200YKMD		
			PUMY-P175/200/225YKM		
			PUMY-CP175/200/225YKM		
			MXZ-8C140/160VAMD-A		
			PUMY-P250/300YBM		
			PUMY-SP250/300YBM-SD.TH		
			MXY-4C100/5C125/6C140VA		
			MXZ-6C53VAM-SG1		
			MXZ-8C112/140/160VAMZ-C		
			MXY-8C112/140/160VAM-CN1		
			MXZ-6C112/8C140/8C160NAM		
			MXZ-8C200VAM-C		
			MXZ-6C112/8C140/8C160NAM		
			MXZ-8C200VAM1-CTMXZ-8C200VAM2-CN1MXZ-8C200VAM2-CN1MXZ-8C200VAM2-CN1MXZ-8C225/250XAM.TH-TW1MXZ-8C225/250XAM.TH-TW1MXZ-8C25/250XAM.TH-TW1		
			MXZ-8C200VAM2-CN1		
			MXZ-8C225/250XAM.TH-TW1		
			MXZ-12C280/335YAM-CN1		
			-	Condensing unit	ECOV-EN75/110/150/185/225/260/300/335MVB
					ECOV-EN75/110/150/185/225/260/300/335VB
					ECOV-X15/37/55VA
			OS		PUHN-200/250YMF-B,YMC
					PUHN-P200/250YMF-B,YMC
					PUHN-200/250YMF-C
	PUHN-P200/250YMF-C				
SC		LMA02/03/04			
IC		DOAS			
FU		FU : Fresh Master			
LC		LC:Lossnay			
AU		PWFY-P100/200VM-E-AU			
		PWFY-P100/140/200VM-E1-AU			
		PWFY-P100/140/200VM-E2-AU			
		PWFY-EP100VM-E1-AU			
		PWFY-EP100VM-E2-AU			
		PWFY-P36/72NMU-E-AU			
BU		PWFY-P100VM-E-BU			
		PWFY-P100VM-E1-BU			
		PWFY-P36NMU-E-BU			
CE/CL		CAHV-P500YA-HPB			
		CAHV-P500YB-HPB			
		CRHV-P600YA-HPB			
		QAHV-N560YA-HPB			
		QAHV-N560YA-KR			
		QAHV-N136TAU-HPB			
CH/CL		EACV-P900YA			
		EAHV-P900YA			
		EAHV-P900YA-H			

Mark	Model
HB	CMB-WP108V-G
	CMB-WP108/1016V-GA1
	CMB-WM108/1016V-AA
	CMB-WM350/500F-AA
HS	CMB-WP108/1016V-GB1
	CMB-WM108/1016V-AB
	CMB-WM108/1016V-BB
HU	CMH-WM250/350/500V-A
CC	RBH-P35NRA-Q-TWN
	RBS-P20/202HRA-Q-TWN

Data before Error occurred Terminology (Outdoor Unit)

Mark	Official Name	Meaning
Ope Mode 1,2	Operation mode	Operation mode for outdoor unit
Ctrl Mode 1,2	Control mode	Control mode for outdoor unit
Ope State 1,2	Operation display1,2	Display of outdoor operation (3-min restart, compressor running, preliminary error, Error, warm-up mode etc)
Indoor mode of BC branch		Indoor mode of BC branch (All cooling ON/OFF etc)
Ctrl Liquid 1		Display of outdoor liquid correction mode
Ope Time Comp 1		Operation time(accumulated) of comp.1
Ope Time Comp 2		Operation time(accumulated) of comp.2
Total Freq(F)	Temporary compressor frequency for calculation	Total temporary compressor frequency
Ope Freq(Hz)	Actual frequency	Compressor operating frequency
Comp Hz		Compressor output frequency before error stop
Hz	Hz up or down	Up or down of compressor frequency
AK	AK up or down	Up or down of heatexchanger capacity(calculation)
AK Capacity	Heat exchanger capacity	Variable which determine the size of outdoor heat exchanger
Toff/NF	Fan speed	Parameter of outdoor fan speed(%)
AL	Accumulator level	Liquid level in the accumulation (0: Undercharge, 1: Adequate, 2: Overcharge)
FAN	Fan	Fan capacity of outdoor unit (not proportional to rotational frequency)
FAN (rpm)	Fan speed	FAN rotation speed[rpm]
FAN-FREE	Fan free run	Outdoor unit fan State
SC	Sub-cool	
SH	Supper heat	
Qjc(Qj(C))	Total capacity code (cool)	Cooling indoor unit capacity
Qjh(Qj(H))	Total capacity code (heat)	Heating indoor unit capacity
Ope Status	Operation Status, Backup mode	Operation Status, Backup mode
Start-up unit	Start-up unit	Start-up unit
Deference of TC	Deference between target TC and real TC	Deference between target TC and real TC
Deference of ET	Deference between target ET and real ET	Deference between target ET and real ET
Target TC		Target high pressure saturation temp.
Target ET		Target low pressure saturation temp.
Forecast TC		Forecast high pressure saturation temp.
Forecast ET		Forecast low pressure saturation temp.
SLEV	Oil return LEV opening	Adjusts the amount of liquid refrigerant and oil returned from the accumulator
LEV1	SC coil LEV opening	Adjusts refrigerant in the bypass pipe from liquid pipe in the outdoor unit in cooling mode.
LEV2,2a,2b	Refrigerant flow adjustment	Adjusts refrigerant flow during heating
LEV1,2,3,4 ,5,6,7,8	LEV pulse of indoor unit 1-8	LEV pulse of indoor unit 1-8
L1	LEV1 opening	Liquid level control, differential pressure control
L2	LEV2 opening	Liquid level control, differential pressure control
L3	LEV3 opening	Liquid level control, differential pressure control
L4	LEV4 opening	Differential pressure control
21S4,21S4a	4-way valve	Switches the cooling/heating cycle (0:Cooling, 1:Heating)
21S4b	4-way valve	Capacity control of heat exchanger
21S4c	4-way valve	Capacity control of heat exchanger (Gas side)
SV1	Solenoid valve output	Returns oil from the oil separator(Bypass between discharge pipe and suction pipe)
SV1a	Solenoid valve output	For opening/closing the bypass circuit under the O/S.
SV2	Solenoid valve output	Switches the capacity control valve inside the compressor(Capacity control full load)
SV21,21/31	Solenoid valve output	For the refrigerant control
SV22,SV32	Solenoid valve output	Switches the capacity control valve Inside the compressor(Capacity control full load)
SV2/3	Solenoid valve output	For the refrigerant control
SV3	Solenoid valve output	Switches the capacity control valve inside the compressor(Capacity control unload)
SV32	Solenoid valve output	Switches the capacity control valve inside the compressor
SV4,SV5	Solenoid valve output	Controls capacity and restricts the high pressure (Frequency control backup) (Bypass between discharge pipe and suction pipe)
SV5B	Solenoid valve output	Restricts the rise in the discharge temperature and bypass circuit at defrosting(liquid bypass)
SV6	Solenoid valve output	Capacity control of heat exchanger
SV6a	Solenoid valve output	Capacity control of heat exchanger
SV6B	Solenoid valve output	Capacity control of heat exchanger
SV6C	Solenoid valve output	Capacity control of heat exchanger
SV6D	Solenoid valve output	Capacity control of heat exchanger
SV6E	Solenoid valve output	Capacity control of heat exchanger

SV6a1/CVa2	Solenoid valve output	For the refrigerant control
SV6b1/CVb2	Solenoid valve output	For the refrigerant control
SV6c1/CVc2	Solenoid valve output	For the refrigerant control
SV7	Solenoid valve output	Bypass control of heat exchanger (Heat exchanger bypass)
SV71,SV72 ,SV73	Solenoid valve output	Capacity control of heat exchanger
SV8	Solenoid valve output	Capacity control of heat exchanger
SV8/9	Solenoid valve output	For the refrigerant control
SV10,11,12	Solenoid valve output	For the refrigerant control
SV13,14,15	Solenoid valve output	For the refrigerant control
SV13t,14t	Solenoid valve output	For the refrigerant control
SVM	Solenoid valve output(SVM)	All cool only units will be open at defrosting
SV*a	Solenoid valve output(SV*a)	Supply refrigerant to the cool only indoor unit
SV*b	Solenoid valve output(SV*b)	Supply refrigerant to the heat pump indoor unit
SV*c	Solenoid valve output(SV*c)	Supply refrigerant to the cool only indoor unit
F	All temporary frequencies	All temporary frequencies (Foc) [Hz]
Comp ON		Display of compressor run (1) / compressor off (0)
72C	Magnetic relay	Magnetic relay(inverter main circuit)
52C1	electromagnetic contactor	52C output On during indoor unit running (inverter main circuit)
52C2	Relay output	Control of compressor2
CH2/3	Accumulator level detection heater output	Accumulator level detection heater output
CH1	Crankcase heater output	Control of compressor heater
52F	Contactors	ON/OFF switch of NO.2 fan
TH1,TH11	Thermistor	Detects the discharge temperature for the high pressure protection.
TH12	Thermistor	Detects the discharge temperature for the high pressure protection
TH2	Thermistor	Detects saturated temperature and then, control the compressor frequency and liquid level in the accumulator (Detects saturated evaporation temperature)
TH3	Thermistor	Detects the liquid level in the accumulator (Detects lower liquid level in the accumulator)
TH4	Thermistor	Detects the liquid level in the accumulator (Detects upper liquid level in the accumulator)
TH5	Thermistor	Controls compressor frequency, controls defrosting and detects the liquid level in heating mode, detects the sub-cool at the heat exchanger exit in combination with 63 HS data, and controls LEV1 (Detects the liquid pipe temperature)
TH6	Thermistor	Detects the ambient temperature and then, controls the fan frequency liquid level in the accumulator, and the opening LEV pulse for oil return. (Detects the ambient air temperature)
TH7,TH8 ,TH9	Thermistor (Controls SC)	Controls LEV1 based on the temperature differences between TH 7,8 and 9.
TH9	Thermistor	Senses the refrigerant composition based on TH2, TH9 and 63LS (composition sensing)
TH10	Thermistor	Detects the oil temperature (Lower compressor shell)
TH10a ,TH10b	Thermistor	Detects outlet temperature of heat exchanger in heating mode. (Gas pipe temperature of heat exchanger)
TH10c	Thermistor	Detects the oil temperature (Lower compressor shell)
T1	TH11 thermistor	LEV control (Controls liquid level) (Temperature at liquid entrance area)
T2	TH12 thermistor	LEV control (Superheat) (Temperature at bypass exit area)
T3	TH13 thermistor	LEV control (Controls liquid level) (Temperature of heat exchanger exit area)
T4	TH14 thermistor	LEV control (Controls liquid level) (Heat exchanger entrance temperature)
T5	TH15 thermistor	LEV control (Superheat) (Bypass exit temperature)
T6	TH16 thermistor	LEV control (Subcool) (Bypass entrance temperature)
THHS	Thermistor	Controls the inverter cooling fan based on the THHS temperature. (Inverter radiator plate temperature)
63HS(1)	High pressure sensor	Detects the discharge pressure and then, protects unit against damage by high pressure.
63HS2	Intermediate pressure sensor	Detects the discharge pressure and then, protects unit against damage by Intermediate pressure. (63HS2 is not displayed according to the unit model.)
HPS1	High pressure sensor 1	Detects high pressure of compressor discharge
HPS2	High pressure sensor 2	Detects high pressure of gas pump
MPS	Middle pressure sensor	Detects middle pressure of BC controller
LPS	Low pressure sensor	Detects low pressure
63LS	Low pressure sensor	Detects the suction pressure and then, senses the refrigerant composition
A_OC	Refrigerant composition(R32)	Real percentage of R32
A_OC*	Refrigerant composition(R32)	Calculated percentage of R32
Tc	Average of saturation gas temperature of high pressure and saturation liquid temperature	For control of compressor frequency and fan speed

	ture of high pressure	
Te	Saturation temperature of low pressure	Same as TH2
Icomp	Direct current	DC of inverter compressor
SV3t	Solenoid valve output	For the refrigerant control
SV4t	Solenoid valve output	For the refrigerant control
SV5t	Solenoid valve output	For the refrigerant control
SV6t	Solenoid valve output	For the refrigerant control
SV7t	Solenoid valve output	For the refrigerant control
SV8t	Solenoid valve output	For the refrigerant control
TH9b	Thermistor	Senses the refrigerant composition based on TH2,TH9b and 63LS. (composition sensing)
TH18	Thermistor	Detects temperature
Ope Mode1,3	Operation mode 1,3	Operation mode for outdoor unit
Ctrl Mode3	Control mode 3	Control mode for outdoor unit
Vdc	Bus voltage	Bus voltage
Idc	COMP operation current (DC)	Peak value [A]
Iu	Phase-U current	Phase-U current of compressor
Iw	Phase-W current	Phase-W current of compressor
PF	Power factor	Inverter output phase angle
Vdcgain	Vdcgain	Vdcgain
offset_u	offset_u	offset_u
offset_w	offset_w	offset_w
vf_ofst_kido	vf_ofst_kido	vf_ofst_kido
vf_ofst_power	vf_ofst_power	vf_ofst_power
Error Code	Error code	Error code
Time(min.sec)	Time(min.sec)	Time(min.sec) before error occurred
SV4a	Solenoid valve output	Heat exchanger capacity control
SV4b	Solenoid valve output	Heat exchanger capacity control
SV4c	Solenoid valve output	Heat exchanger capacity control
SV4d	Solenoid valve output	Heat exchanger bypass ON/OFF
THHS2	Thermistor THHS2	Comp inverter2 radiator plate temperature
THHS5	Thermistor THHS5	Fan inverter of outdoor unit radiator plate temperature
T5b	Thermistor TH5b	Controls defrosting (start/end) in heating mode (No.1 compressor)
TS5	Thermistor THHS5	Fan inverter of heat exchanger unit radiator plate temperature
T1(BC/main BC)	TH11 thermistor	LEV control (Controls liquid level) (Temperature at liquid entrance area)
T2(BC/main BC)	TH12 thermistor	LEV control (Superheat) (Temperature at bypass exit area)
T5(BC/main BC)	TH15 thermistor	LEV control (Superheat) (Temperature at LEV3 exit area)
T6(BC/main BC)	TH16 thermistor	LEV control (Subcool) (Temperature at LEV3 entrance area)
T2(sub BC1)	TH12 thermistor of sub BC	LEV control (Superheat) (Temperature at bypass exit area)
T5(sub BC1)	TH15 thermistor of sub BC1	LEV control (Superheat) (Temperature at LEV3 exit area)
T2(sub BC2)	TH12 thermistor of sub BC2	LEV control (Superheat) (Temperature at bypass exit area)
T5(sub BC2)	TH15 thermistor of sub BC2	LEV control (Superheat) (Temperature at LEV3 exit area)
P1(BC/main BC)	High pressure (63HS1)	Detects the high pressure at the liquid side
P3(BC/main BC)	Intermediate pressure (63HS3)	Detects the intermediate pressure
L1(BC/main BC)	LEV1 opening	Liquid level control, differential pressure control
L2(main BC)	LEV2 opening	Liquid level control, differential pressure control
L3(BC/main BC)	LEV3 opening	Liquid level control, differential pressure control, superheat of bypass control
L3(sub BC1)	LEV3 opening of sub BC1	Liquid level control, differential pressure control, superheat of bypass control
L3(sub BC2)	LEV3 opening of sub BC2	Liquid level control, differential pressure control, superheat of bypass control
Idc1	DC trunk line current	DC trunk line current of inverter1
Vdc1	Bus voltage	Bus voltage of inverter1
Iu1	Phase-U current	Phase-U current of compressor1
Iw1	Phase-W current	Phase-W current of compressor1
PF1	Power factor	Inverter output phase angle of inverter1
Vdcgain1	Vdcgain	Vdcgain of inverter1
offset_u1	offset_u	offset_u of inverter1
offset_w1	offset_w	offset_w of inverter1
vf_ofst_kido1	vf_ofst_kido	vf_ofst_kido of inverter1
vf_ofst_power1	vf_ofst_power	vf_ofst_power of inverter1
Idc2	DC trunk line current	DC trunk line current of inverter2
Vdc2	Bus voltage	Bus voltage of inverter2
Iu2	Phase-U current	Phase-U current of compressor2
Iw2	Phase-W current	Phase-W current of compressor2
PF2	Power factor	Inverter output phase angle of inverter2
Vdcgain2	Vdcgain	Vdcgain of inverter2
offset_u2	offset_u	offset_u of inverter2
offset_w2	offset_w	offset_w of inverter2
vf_ofst_kido2	vf_ofst_kido	vf_ofst_kido of inverter2

vf_ofst_power2	vf_ofst_power	vf_ofst_power of inverter2
FAN2	Fan	Fan capacity of heat exchanger unit
FAN2 (rpm)	Fan speed	FAN rotation speed[rpm]
FAN2-FREE	Fan free run	Outdoor unit fan State
Primary	Primary	Indicates whether the unit is primary or secondary
SV5D	Solenoid valve output	Closes when outdoor unit stops
OC Total Freq	Total Frequency of OC unit	Total temporary frequency of OC unit
OS Total Freq	Total Frequency of OS unit	Total temporary frequency of OS unit
Total Freq	Total Frequency of OC and OS units	Total temporary frequency of OC and OS units
IH	IH bound power	IH restricted electricity
H-Def1	Continuous Heating	Heat exchanger1 defrost
H-Def2	Continuous Heating	Heat exchanger2 defrost

Data before Error occurred Terminology (Condensing unit)

Mark	Official Name	Meaning
TH1	Discharge pipe temperature	Discharge pipe temperature of the compressor
TH2	Compressor shell oil temperature	Oil temperature of the compressor shell bottom
TH4	-	For Japan market model
TH5	-	For Japan market model
TH6	Outside air temperature	Temperature of outside air
TH7	Suction pipe temperature	Suction pipe temperature of the compressor
TH8	Liquid pipe temperature	Temperature of the liquid pipe
HPS	High-pressure	Use for controlling compressor, fan and high-pressure protection.
LPS	Low-pressure	Use for controlling compressor, fan and low-pressure protection.
Idc	Direct current(INV DC current)	Peak value of the DCCT detection
Vdc	Bus voltage(INV DC voltage)	DC bus voltage
Tc	Condensation temperature (Converted high-pressure saturation temperature)	Condensation temperature of unit module.
Te	Evaporation temperature (Converted low-pressure saturation temperature)	Evaporation temperature of unit module.
THHS	Inverter heatsink temperature	Temperature of the heatsink. for controlling the inverter cooling fan.
AL	Liquid refrigerant flooding level	Determine the liquid refrigerant flooding condition. 0: dry, 1: wet, 2: liquid refrigerant flooding
Tem0	-	For Japan market model
Tem1	-	For Japan market model
Tcm	Target condensation temperature	Target condensation temperature of unit module. When unit correspondencing, It doesn't show because the controlling use representative value.
Tem	Target evaporation temperature	Target evaporation temperature of unit module.
Delta-Tcm	Target condensation temperature difference	Difference between the target condensation temperature and actual temperature(Tcm-Tc)
Delta-Tem	Target evaporation temperature difference	Difference between the target evaporation temperature and actual temperature(Tem-Te)
Coff	Low-pressure cut-off value	Low-pressure cutoff compressor OFF-threshold Unit:Mpa
Con	Low-pressure cut-on value	Low-pressure cutoff compressor ON-threshold Unit:Mpa
lead-in speed	Compressor suction speed	Rate of the low-pressure change of compressor Unit:Mpa/10s
Discharge-SH	Compressor discharge superheat	Discharge superheat of the compressor(TH1-Tc)
S-TH6	Representative outside air temperature	Representative outside air temperature of the overall unit
S-HPS	Representative high-pressure	Representative high-pressure of the overall unit Unit:Mpa
S-LPS	Representative low-pressure	Representative low-pressure of the overall unit Unit:Mpa
S-Coff	Overall Low-pressure cutoff compressor OFF-threshold	Representative low-pressure cutoff compressor OFF-threshold of the overall unit Unit:Mpa
S-Con	Overall Low-pressure cutoff compressor ON-threshold	Representative low-pressure cutoff compressor ON-threshold of the overall unit Unit:Mpa
Iu	Compressor U-phase current value	Inverter output current value(U-phase)
Iw	Compressor W-phase current value	Inverter output current value(W-phase)
Vunb	Limit of unbalance of power supply voltage	Show the state of the unbalance limiting control of power supply voltage. 1: Under control, 0: Nomal
Fm	Target frequency of the compressor(unit module value) (Hz)	Target frequency of the compressor.
FAN(AK%)	Heat exchanger capacity (Fan output)	Variable of the motor rotation speed of the condenser fan (%)
S-Fm(Hz)	Target frequency of the compressor(unit module value) (Hz)	Target frequency of the compressor of unit module.
X101	Auxiliary relay<X101> status	Used for the bypass solenoid valve output(the primary-side power-supply voltage). 1: ON, 0: OFF

X102	Auxiliary relay<X102> status	For Japan market model
X103	Auxiliary relay<X103> status	Used for the crankcase heater output (the primary-side power-supply voltage). 1: ON, 0: OFF
X104	Auxiliary relay<X104> status	Used for the solenoid valve <injection> output (the primary-side power-supply voltage). 1: ON, 0: OFF
X105	Auxiliary relay<X105> status	Used for the high/low pressure bypass solenoid valve output (the primary-side power-supply voltage). 1: ON, 0: OFF
X106	Auxiliary relay<X106> status	The solenoid valve <oil return> output (21Q1~3) (the primary-side power-supply voltage). 1: ON, 0: OFF
X107	Auxiliary relay<X107> status	Used for the output of the operating status of the compressor (auxiliary relay<X61> drive) (the primary-side power-supply voltage). 1: ON, 0: OFF
X108	Auxiliary relay<X108> status	Used for 52F output (the primary-side power-supply voltage). 1: ON, 0: OFF
X109	Auxiliary relay<X109> status	-
X110	Auxiliary relay<X110> status	-
X111	Auxiliary relay<X111> status	Used for the unit operation signal output (auxiliary relay<X4>drive) (the primary-side power-supply voltage). 1: ON, 0: OFF
X112	Auxiliary relay<X112> status	Used for the error alarm signal output (auxiliary relay<X5>drive) (the primary-side power-supply voltage). 1: ON, 0: OFF
X172	Auxiliary relay<X172> status	Used for the 72C drive source output (the primary-side power-supply voltage). 1: ON, 0: OFF
72C	Output of 72C for export	-
Err	Error output	-
COMP	Compressor ON/OFF output	-
LEV	LEV output value	LEV output value of the linear expansion valve <injection>. 0~480 pulse

Data before Error occurred Terminology (ECOV-X15/37/55VA)

Mark	Official Name	Meaning
TH1	Discharge pipe temperature	Discharge pipe temperature of the compressor
TH2	Compressor oil temperature	Oil temperature of the compressor shell bottom
TH4	Gascooler outlet pipe temperature	Temperature of the gascooler outlet pipe
TH5	Heat exchanger outlet pipe temperature	Temperature of the heat exchanger outlet pipe
TH6	Outside air temperature	Temperature of outside air
TH7	Suction pipe temperature	Suction pipe temperature of the compressor
TH8	Liquid pipe temperature	Temperature of the liquid pipe
TH9	Oil pipe temperature	Temperature of the oil pipe
HPS1	High-pressure1	Use for controlling compressor, fan and high-pressure protection.
HPS2	High-pressure2	Use for controlling compressor, fan and high-pressure protection.
MPS	Middle-pressure	Use for controlling compressor, fan and middle-pressure protection.
LPS	Low-pressure	Use for controlling compressor, fan and low-pressure protection.
Vdc	Bus voltage(INV DC voltage)	DC bus voltage
Iac	Input current(INV AC current)	AC input current
Tc	Condensation temperature (Converted high-pressure saturation temperature)	Condensation temperature of unit module.
Te	Evaporation temperature (Converted low-pressure saturation temperature)	Evaporation temperature of unit module.
THHS	Inverter heatsink temperature	Temperature of the heatsink. For controlling the inverter cooling fan.
AL	Liquid refrigerant flooding level	Determine the liquid refrigerant flooding condition. 0: dry, 1: wet, 2: liquid refrigerant flooding
Tem0	Target evaporation temperature setting value	Target evaporation temperature setting value
Tcm	Target condensation temperature	Target condensation temperature of unit module. When unit correspondencing, it doesn't show because the controlling use representative value.
Tem	Target evaporation temperature	Target evaporation temperature of unit module.
Delta-Tcm	Target condensation temperature difference	Difference between the target condensation temperature and actual temperature(Tcm-Tc)
Delta-Tem	Target evaporation temperature difference	Difference between the target evaporation temperature and actual temperature(Tem-Te)
Coff	Low-pressure cut-off value	Low-pressure cutoff compressor OFF-threshold
Con	Low-pressure cut-on value	Low-pressure cutoff compressor ON-threshold
lead-in speed	Compressor suction speed	Rate of the low-pressure change of compressor Unit:Pressure/10s
Discharge-SH	Compressor discharge superheat	Discharge superheat of the compressor (TH1-Tc)
Iu	Compressor U-phase current value	Inverter output current value(U-phase)
Iw	Compressor W-phase current value	Inverter output current value(W-phase)
Vunb	Limit of unbalance of power supply voltage	Show the state of the unbalance limiting control of power supply voltage. 1: Under control, 0: Nomal
Fm	Target frequency of the compressor(unit module value) (Hz)	Target frequency of the compressor
FAN(AK%)	Heat exchanger capacity (Fan output)	Variable of the motor rotation speed of the condenser fan (%)
S-Fm(Hz)	Target frequency of the compressor(overall unit)(Hz)	Target frequency of the compressor of the overall unit
X101	Auxiliary relay<X101> status	Show the output status of the auxiliary relay <X101>. 1: ON, 0: OFF
X102	Auxiliary relay<X102> status	Show the output status of the auxiliary relay <X102>. 1: ON, 0: OFF
X103	Auxiliary relay<X103> status	Show the output status of the auxiliary relay <X103>. 1: ON, 0: OFF
X104	Auxiliary relay<X104> status	Show the output status of the auxiliary relay <X104>. 1: ON, 0: OFF
X105	Auxiliary relay<X105> status	Show the output status of the auxiliary relay <X105>. 1: ON, 0: OFF
X107	Auxiliary relay<X107> status	Show the output status of the auxiliary relay <X107>. 1: ON, 0: OFF
X111	Auxiliary relay<X111> status	Show the output status of the auxiliary relay <X111>.

		1: ON, 0: OFF
X112	Auxiliary relay<X112> status	Show the output status of the auxiliary relay <X112>. 1: ON, 0: OFF
X113	Auxiliary relay<X113> status	Show the output status of the auxiliary relay <X113>. 1: ON, 0: OFF
13V-3	Fan1 auxiliary relay<X10> status	Show the output status of the auxiliary relay <X10> of fan1. 1: ON, 0: OFF
13V-4	Fan2 auxiliary relay<X10> status	Show the output status of the auxiliary relay <X10> of fan2. 1: ON, 0: OFF
72C	Output of 72C	Used for the 72C drive source output. 1: ON, 0: OFF
LEV1~LEV4	LEV output value	LEV output value
Nm	Target fan rotation speed	Target rotation speed of fan
avgNj1	Fan actual rotation speed1	Actual rotation speed of fan1
avgNj2	Fan actual rotation speed2	Actual rotation speed of fan2

Data before Error occurred Terminology (Outdoor Sub Unit)

Mark	Official Name	Meaning
Ope State 1		Display of outdoor operation (3-min restart, compressor running, preliminary error, Error, warm-up mode etc)
Ope State 2		Display of outdoor operation (Power failure LEV ON/OFF)
Ctrl Liquid		Display of outdoor liquid correction mode
Ope Time Comp1		Operation time(accumulated) of comp.
Comp ON		Display of compressor run (1) / compressor off (0)
52C1	electromagnetic contactor	Control of compressor
CH2/3	Accumulator level detection heater output	Accumulator level detection heater output
Akx(2)	Heat exchanger capacity	Variable which determine the size of outdoor heat exchanger
AL	Accumulator level	Liquid level in the accumulation (0: Undercharge, 1: Adequate, 2 :Overcharge)
LEV1	SC coil LEV opening	Adjusts refrigerant in the bypass pipe from liquid pipe in the outdoor unit in cooling mode.
LEV2	Liquid pipe LEV opening	Control of refrigerant in heating mode
21S4(a)	4-way valve	Switches the cooling/heating cycle (0:Cooling, 1:Heating)
21S4(b)	4-way valve	Capacity control of heat exchanger
SV1	Solenoid valve output	Returns oil from the oil separator (Bypass between discharge pipe and suction pipe)
SV4	Solenoid valve output	Control of low pressure (evaporation refrigerant in Accumulator)
SV5B(b)	Solenoid valve output	Control of refrigerant amount in liquid line
SV22/32	Solenoid valve output	For the refrigerant control
TH11	Thermistor	Detects the discharge temperature for the high pressure protection.
TH3	Thermistor	Detects the liquid level in the accumulator (Detects lower liquid level in the accumulator)
TH4	Thermistor	Detects the liquid level in the accumulator (Detects upper liquid level in the accumulator)
TH5	Thermistor	Controls compressor frequency, controls defrosting and detects the liquid level in heating mode, detects the sub-cool at the heat exchanger exit in combination with 63 HS data, and controls LEV1 (Detects the liquid pipe temperature)
TH6	Thermistor	Detects ambient temperature
TH7(8,9)	Thermistor (Controls SC)	Controls LEV1 based on the temperature differences between TH 7,8 and 9.
TH10a	Thermistor	Detects outlet temperature of heat exchanger in heating mode. (Gas pipe temperature of heat exchanger)
TH10b	Thermistor	Detects temperature of balance pipe
63LS	Low pressure sensor	Detects the suction pressure and then, senses the refrigerant composition.

Data before Error occurred Terminology (Multidensity Modbus I/F)

Mark	Official Name	Meaning
TAmb	Thermistor(Return air temperature)	Detects and controls the room temperature of indoor units
TGEv	Thermistor(Gas line temperature)	Indoor unit gas side piping temperature
TASup	Thermistor(Supply air temperature)	Detects and controls the delivery temperature from the indoor unit
TsGEv	Gas line saturation temperature	Saturation temperature conversion value of gas piping pressure of indoor unit
PGEv	Pressure (Gas line pressure)	Detects gas line pressure
TO	Target room temperature	Temperature set by Indoor unit
LI	Electric expansion valve	Indoor unit EEV opening pulse
FAN	Fan data	Indoor unit fan output

Data before Error occurred Terminology (CAHV-P500YA-HPB,CAHV-P500YB-HPB)

Mark	Official Name	Meaning
TH1	Thermistor	Discharge Ref temperature 1
TH2	Thermistor	Suction Ref temperature 1
TH3	Thermistor	Shell Ref temperature 1
TH4	Thermistor	Air hex Ref temperature 1
TH5	Thermistor	Discharge Ref temperature 2
TH6	Thermistor	Suction Ref temperature 2
TH7	Thermistor	Shell Ref temperature 2
TH8	Thermistor	Air hex Ref temperature 2
TH9	Thermistor	Outdoor temperature 1
TH10	Thermistor	Water Inlet temperature 1
TH11	Thermistor	Water Outlet temperature 1
TH12	Thermistor	Water Inlet temperature 2
TH13	Thermistor	Water Outlet temperature 2
TH14	Thermistor	Representative water temperature 1
TH15	Thermistor	Representative water temperature 2
THHS	Thermistor	IGBT temperature
HP1	Pressure sensor	High pressure sensor
LP1	Pressure sensor	Low pressure sensor
Ts		Target water temperature
Twi		Current inlet water temperature
Two		Current outlet water temperature
Twg	Main water temperature	TH14 or TH15 temperature which is selected
Tout	Main outdoor temperature	4-20mA2 or IT temperature which is selected
0-10IN	0-10V/2-10V	External analog input for Target water temp (0-10V)
1-5IN	1-5V	External analog input for Target water temp (1-5V)
4/20IN1	4-20mA1	External analog input for Target water temp (4-20mA)
Idc(Comp)		DC trunk line current [A]
Iu(Comp)		Phase-U current of compressor [A]
Iw(Comp)		Phase-W current of compressor [A]
Vdc(Comp)		COMP bus voltage [V]
4/20IN2	4-20mA2	External analog input for Outdoor temp (4-20mA2)
SHs		Target superheat value at the suction pipe to compressor
SH		difference from suction gas temp to saturated gas temp
Shell-SH		superheat value at the suction point of compressor
Td-SHs		Target superheat value at the discharged pipe from compressor
Td-SH		superheat value at the discharged point from compressor
COMP1		operating frequency in main circuit
COMP2		operating frequency in sub circuit
FAN(Hz)		Outdoor unit fan output [%]
LEV1		LEV1 pulse
LEV2		LEV2 pulse at HIC circuit

Data before Error occurred Terminology (CRHV-P600YA-HPB)

Mark	Official Name	Meaning
Ver	Software Version	Program ROM
TH1	Thermistor	Discharge Ref temp.1
TH2	Thermistor	Suction Ref temp.1
TH3	Thermistor	Shell Ref temp.1
TH4	Thermistor	Heat exchanger wall temp.1
TH5	Thermistor	Discharge Ref temp.2
TH6	Thermistor	Suction Ref temp.2
TH7	Thermistor	Shell Ref temp.2
TH8	Thermistor	Heat exchanger wall temp.2
TH9	Thermistor	Outdoor temp.1
TH11	Thermistor	Water inlet temp.1
TH12	Thermistor	Water outlet temp.1
TH13	Thermistor	Heat source inlet temp.1
TH14	Thermistor	Heat source outlet temp.1
TH15	Thermistor	External Water sensor.1
TH16	Thermistor	External Water sensor.2
TH17	Thermistor	Hot Water inlet temp.2
TH18	Thermistor	Hot Water outlet temp.2
TH20	Thermistor	Heat source inlet temp.2
HP	63HS	High pressure sensor
LP	63LS	Low pressure sensor
Vdc	-	COMP bus voltage [V]
Iu	-	Phase-U current of compressor [A]
Iw	-	Phase-W current of compressor [A]
Ts	-	Target water temperature
Twi	-	Current inlet hot water temperature
Two	-	Current outlet hot water temperature
Twg	Main water temperature	TH15 or TH16 temperature which is selected
SHs	-	Target superheat value at the suction pipe to compressor
SHt	-	-
SHb	-	-
Shell-SH	-	Superheat value at the shell of the compressor
Td-SHs	-	Target superheat value at the discharge pipe
Td-SH	-	Superheat value at the discharge pipe
THHS	Thermistor	IGBT temperature
LEV1	-	Electronic expansion valve(Main/Sub circuit)
LEV2	-	-
LEV3	-	Electronic expansion valve(Main/Sub injection circuit)
COMP1(Hz)	-	Operating frequency in main circuit [Hz]
COMP2(Hz)	-	Operating frequency in sub circuit [Hz]
4-20mA1	-	External analog input for Target water temp (4-20mA1)
0-10V	-	External analog input for Target water temp (0-10V/2-10V)
1-5V	-	External analog input for Target water temp (1-5V)
4-20mA2	-	External analog input for Outdoor temp (4-20mA2)

Data before Error occurred Terminology

QAHV-N560YA-HPB, QAHV-N560YA-KR, QAHV-N136TAU-HPB

Mark	Official Name	Meaning
TH1	Compressor Discharge Refrigerant temperature	
TH2	Compressor Suction Refrigerant temperature	
TH3	Gascooler Refrigerant temperature	
TH4	Air hex(Heat exchange) inlet Refrigerant temperature	
TH5	Air hex(Heat exchange) outlet Refrigerant temperature	
TH9	Outdoor temperature	
TH11	Water outlet temperature	
TH12	Water inlet temperature	
TH14	Shell Refrigerant temperature	
TH15	External water sensor.1	
TH16	External water sensor.2	
TH17	External water sensor.3	
TH15p	External water sensor.4(For 6 sensor system only)	
TH16p	External water sensor.5(For 6 sensor system only)	
TH17p	External water sensor.6(For 6 sensor system only)	
TH18	External Water sensor (secondary circuit)	
TH19	No use	
THHS	Heat sink temperature	
HP1	High pressure sensor [Mpa]	
HPb	High pressure amplitude amplitude value [Mpa]	
LP1	Low pressure sensor [Mpa]	
4/20IN	Analog input 4-20mA/0-10V/1-5V/2-10V	External analog input for Target water temperature
Idc	DC trunk line current [A]	
Iu	U-Phase current effective value[A]	
Iw	W-Phase current effective value[A]	
Vdc	Bus voltage [V]	
Vp-p	No use	
Target superheat		
Real superheat		
FlowRate1(L/m)	Flow sensor.1	flow rate (liter per minutes)
FlowRate2(L/m)	Flow sensor (secondary circuit)	flow rate (liter per minutes)
FlowRate3(L/m)	No use	
Pump(%)	Pump output	Percentage of pump output (current value / maximum value) for water flow rate control
FAN(Hz)	Fan frequency	
F(Hz)	Compressor frequency	
MVW1		Flow control valve MV 1 Valve opening
LEVA		Command value of LEVA pulse of unit
LEVC		Command value of LEVC pulse of unit

Data before Error occurred Terminology (EACV-P900YA,EAHV-P900YA,EAHV-P900YA-H)

Mark	Official Name	Meaning
Ver	Software Version	Program ROM
TH1	Thermistor	Water inlet temp. 1
TH2	Thermistor	Water inlet temp. 2
TH3	Thermistor	Water outlet temperature
TH5	Thermistor	ACC Inlet Ref temperature
TH6	Thermistor	Air hex Ref temperature
TH7	Thermistor	Water hex Ref temperature
TH10	Thermistor	Outdoor temperature
TH11	Thermistor	Discharge Ref temperature
TH15	Thermistor	External Water sensor
HP	63HS	High pressure sensor
LP	63LS	Low pressure sensor
Vdc	-	COMP bus voltage [V]
Iu	-	Phase-U current of compressor [A]
Iw	-	Phase-W current of compressor [A]
Ts	-	Target water temperature
Twi	-	Current inlet water temperature
Two	-	Current outlet water temperature
Twg	Main water temperature	External water temperature
Tout	-	Outdoor air temperature by BMS
SHs	-	Target superheat value at the ACC inlet pipe
SCs	-	Target subcool value at the ACC inlet pipe
SH	-	-
SC	-	-
Td-SH	-	Superheat value at the discharge pipe
THHS	Thermistor	IGBT temperature
LEV1	-	Electronic expansion valve(Main/Sub circuit)
COMP1(Hz)	-	Operating frequency in main circuit [Hz]
FAN1(Hz)	-	Operating frequency of fan moter1 [Hz]
FAN2(Hz)	-	Operating frequency of fan moter2 [Hz]
FAN3(Hz)	-	Operating frequency of fan moter3 [Hz]
4-20mA1	-	External analog input for Target water temp (4-20mA1)
0-10V	-	External analog input for Target water temp (0-10V/2-10V)
1-5V	-	External analog input for Target water temp (1-5V)

Data before Error occurred Terminology (CMB-WP108V-G)

Mark	Official Name	Meaning
Time(min.sec)	Time(min.sec)	Time(min.sec) before error occurred
TH11	Thermistor	
TH12	Thermistor	
TH13	Thermistor	
TH14	Thermistor	
TH15	Thermistor	
TH16	Thermistor	
TH31a	Thermistor	
TH31b	Thermistor	
TH31c	Thermistor	
TH31d	Thermistor	
TH31e	Thermistor	
TH31f	Thermistor	
TH31g	Thermistor	
TH31h	Thermistor	
TH32	Thermistor	
TH33	Thermistor	
TH34	Thermistor	
TH35	Thermistor	
TH36	Thermistor	
TH37	Thermistor	
Ps1	Pressure sensor	
SWgp1	SWgp1 signal	
SWgp2	SWgp2 signal	
SWgp3	SWgp3 signal	
PS	Power failure detection	
Float	Float SW setting value	
Fcon	Float SW setting value	
Pump11	Pump1 Input	number of rotations
Pump12	Pump2 Input	number of rotations
PumpO1	Pump1 Output	variable for control
PumpO2	Pump2 Output	variable for control
HB Sig	Outdoor unit operation control	Outdoor unit operation control signal to OC
OC Sig	Indoor unit operation control	Indoor unit operation control signal from OC
sigmaQj(C)	Total capacity code (cooling)	Outdoor unit operation control signal to OC
sigmaQj(H)	Total capacity code (heating)	Indoor unit operation control signal from OC
21S4Ma	4-way valve	Cooling indoor unit capacity
21S4Mb	4-way valve	Heating indoor unit capacity
SVM1	Solenoid valve	
72C	Contactora	
1a-1h	2 way valve MV1*	"0" represents "valve opening = 85" "1" represents "valve opening = 800" "2" represents "valve opening = 1600"
2a-2h	2 way valve MV2*	"0" represents "valve opening = 85" "1" represents "valve opening = 800" "2" represents "valve opening = 1600"
3a-3h	3 way valve MV3*	
LEV1	Linear expansion valve	
LEV2	Linear expansion valve	
LEV3	Linear expansion valve	
Error Code	Error Code	Error Code

Data before Error occurred Terminology (CMB-WP108/1016V-GA1, CMB-WM108/1016V-AA)

Mark	Official Name	Meaning
Time(min.sec)	Time(min.sec)	Time(min.sec) before error occurred
TH11	Thermistor sensor	Liquid-side refrigerant temp. of Heating-main heat exchanger
TH12	Thermistor sensor	Liquid-side refrigerant temp. of Cooling-main heat exchanger
TH13	Thermistor sensor	Gas-side refrigerant temp. of Heating-main heat exchanger
TH14	Thermistor sensor	Gas-side refrigerant temp. of Cooling-main heat exchanger
TH15	Thermistor sensor	Bypass inlet temperature
TH16	Thermistor sensor	Bypass outlet temperature
TH31a-p	Thermistor sensor	1st-16th port returned water temp.
PS1	Pressure sensor PS1	Detects the high pressure at the liquid side.
PS3	Pressure sensor PS3	Detects the low pressure.
TH32	Thermistor sensor	Outlet water temp. of Heating-main heat exchanger
TH33	Thermistor sensor	Outlet water temp. of Cooling-main heat exchanger
TH34	Thermistor sensor	Water pump 2 discharge water temp.
TH35	Thermistor sensor	Water pump 1 discharge water temp.
SH1	Superheat	Superheat at bypass exit area. TH13-TH11 (only HB)
SH2	Superheat	Superheat at bypass exit area. TH14-TH12 (only HB)
SC1	Subcool	Subcool at liquid entrance area. PT1-TH11 (only HB)
SC2	Subcool	Subcool at liquid entrance area. PT1-TH12 (only HB)
PT1	Average of saturation gas temperature of high pressure and saturation liquid temperature of high pressure	For control of LEV (LEV1,LEV2,LEV3). (only HB)
dPHM	Differential pressure	PS1-PS3 Pressure.(only HB)
PS	Power failure detection	
Float	Float SW	
FIcon	Float SW	
PumpI1	Pump1 Input	number of rotations
PumpI2	Pump2 Input	number of rotations
PumpO1	Pump1 Output	variable for control
PumpO2	Pump2 Output	variable for control
sigmaQj(C)	Total capacity code (cooling)	Cooling indoor unit capacity
sigmaQj(H)	Total capacity code (heating)	Heating indoor unit capacity
21S4Ma	4-way valve	Switches the cooling/heating cycle (0:Cooling, 1:Heating)
21S4Mb	4-way valve	Heat exchanger capacity control
SVM1	Solenoid valve	Refrigerant flow volume control
HB Sig	Outdoor unit operation control	Outdoor unit operation control signal to OC
OC Sig	Indoor unit operation control	Indoor unit operation control signal from OC
VB3a-3p	3-way valve MV3*	Controls the water flow path and the water flow rate
LEV1	LEV1 opening	Liquid level control, differential pressure control
LEV2	LEV2 opening	Liquid level control, differential pressure control
LEV3	LEV3 opening	Liquid level control, differential pressure control, superheat of bypass control
Error Code	Error Code	Error Code
Time(min.sec)	Time(min.sec)	Time(min.sec) before error occurred

**Data before Error occurred Terminology
(CMB-WP108/1016V-GB1, CMB-WM108/1016V-AB)**

Mark	Official Name	Meaning
Time(min.sec)	Time(min.sec)	Time(min.sec) before error occurred
TH31a-p	Thermistor sensor	1st-16th port returned water temp.
TH32	Thermistor sensor	Outlet water temp. of Heating-main heat exchanger
TH33	Thermistor sensor	Outlet water temp. of Cooling-main heat exchanger
PS	Power failure detection	
Float	Float SW	
Ficon	Float SW	
VB3a-3p	3-way valve VB3*	Controls the water flow path and the water flow rate
Error Code	Error Code	Error Code
Time(min.sec)	Time(min.sec)	Time(min.sec) before error occurred
TH31a-p	Thermistor sensor	1st-16th port returned water temp.
TH32	Thermistor sensor	Outlet water temp. of Heating-main heat exchanger
TH33	Thermistor sensor	Outlet water temp. of Cooling-main heat exchanger
PS	Power failure detection	
Float	Float SW	
Ficon	Float SW	
VB3a-3p	3-way valve VB3*	Controls the water flow path and the water flow rate
Error Code	Error Code	Error Code

Data before Error occurred Terminology (CMB-WM350/500F-AA)

Mark	Official Name	Meaning
Time(min.sec)	Time(min.sec)	Time(min.sec) before error occurred.
TH11	Thermistor (Refrigerant side)	Liquid-side refrigerant temperature of Heating-main heat exchanger.
TH12	Thermistor (Refrigerant side)	Liquid-side refrigerant temperature of Cooling-main heat exchanger.
TH13	Thermistor (Refrigerant side)	Gas-side refrigerant temperature of Heating-main heat exchanger.
TH14	Thermistor (Refrigerant side)	Gas-side refrigerant temperature of Cooling-main heat exchanger.
TH15	Thermistor (Refrigerant side)	Bypass inlet temperature.
TH16	Thermistor (Refrigerant side)	Bypass outlet temperature.
TH31a-f	Thermistor (Water side)	1st-6th port returned water temperature.
TH32	Thermistor (Water side)	Outlet water temperature of Heating-main heat exchanger.
TH33	Thermistor (Water side)	Outlet water temperature of Cooling-main heat exchanger.
TH34	Thermistor (Water side)	Water pump 2 discharge water temperature.
TH35	Thermistor (Water side)	Water pump 1 discharge water temperature.
THHS1	Thermistor	Pump1-inverter Heat sink temperature.
THHS2	Thermistor	Pump2-inverter Heat sink temperature.
PS1	Pressure sensor (Refrigerant side)	Refrigerant high pressure at the gas side.
PS3	Pressure sensor (Refrigerant side)	Refrigerant medium pressure.
Pw1(kPa)	Pressure sensor (Water side)	Water pump1 suction water pressure.
Pw2(kPa)	Pressure sensor (Water side)	Water pump1 discharge water pressure.
Pw3(kPa)	Pressure sensor (Water side)	Water pump2 suction water pressure.
Pw4(kPa)	Pressure sensor (Water side)	Water pump2 discharge water pressure.
SH1	Superheat	Superheat at exit area of heat exchanger. TH13-TH11
SH2	Superheat	Superheat at exit area of heat exchanger. TH14-TH12
SC1	Subcool	Subcool at exit area of heat exchanger. PT1-TH11
SC2	Subcool	Subcool at exit area of heat exchanger. PT1-TH12
PT1	Average of saturation gas temperature of high pressure and saturation liquid temperature of high pressure	For control of LEV. (LEV1,LEV2,LEV3)
dPHM	Differential pressure	PS1-PS3 Pressure.
PS	Power failure detection	("OFF" : normal, "ON" : power failure)
PumpO1	Pump1 Output	Variable for control.
PumpO2	Pump2 Output	Variable for control.
Vdc1	Pump1 bus voltage	Pump1 bus voltage. [V]
Iu1	Pump1 U-Phase current effective value	Pump1 U-Phase current effective value. [A]
Iw1	Pump1 W-Phase current effective value	Pump1 W-Phase current effective value. [A]
Vdcgain1	Pump1-inverter Vdcgain	Pump1-inverter Vdcgain.
offset_u1	Pump1-inverter offset_u	Pump1-inverter offset_u.
offset_w1	Pump1-inverter offset_w	Pump1-inverter offset_w.
vf_ofst_pwr1	Pump1-inverter vf_ofst_pwr	Pump1-inverter vf_ofst_pwr.
Vdc2	Pump2 bus voltage	Pump2 bus voltage. [V]
Iu2	Pump2 U-Phase current effective value	Pump2 U-Phase current effective value. [A]
Iw2	Pump2 W-Phase current effective value	Pump2 W-Phase current effective value. [A]
Vdcgain2	Pump2-inverter Vdcgain	Pump2-inverter Vdcgain.
offset_u2	Pump2-inverter offset_u	Pump2-inverter offset_u.
offset_w2	Pump2-inverter offset_w	Pump2-inverter offset_w.
vf_ofst_pwr2	Pump2-inverter vf_ofst_pwr	Pump2-inverter vf_ofst_pwr.
QjC	Total capacity code (cooling)	Cooling indoor unit capacity.
QjH	Total capacity code (heating)	Heating indoor unit capacity.
21S4Ma	4-way valve	Switches the cooling/heating cycle. (0:Heating, 1:Cooling)
21S4Mb	4-way valve	Switches the cooling/heating cycle. (0:Cooling, 1:Heating)
SV1	Solenoid valve	Refrigerant flow volume control.
MV1	3 way valve MV1	Water supply valve for cooling circuit and heating circuit.
VB3a-f	Valve block VB3*	Controls the water flow path and the water flow rate.
LEV1	LEV1 opening	Liquid level control, differential pressure control.
LEV2	LEV2 opening	Liquid level control, differential pressure control.
LEV3	LEV3 opening	Liquid level control, differential pressure control, superheat of bypass control.
Error Code	Error code	Error code.

Data before Error occurred Terminology (CMB-WM108/1016V-BB)

Mark	Official Name	Meaning
Time(min.sec)	Time(min.sec)	Time(min.sec) before error occurred.
TH31a-p	Thermistor (Water side)	1st-16th port returned water temperature.
TH32	Thermistor (Water side)	Outlet water temperature of Heating-main heat exchanger.
TH33	Thermistor (Water side)	Outlet water temperature of Cooling-main heat exchanger.
PS	Power failure detection	("OFF" : normal, "ON" : power failure)
Float	Float switch	("OFF" : error, "ON" : normal)
Flcon	Detection of the disconnected float switch	("OFF" : disconnection, "ON" : connection)
VB3a-p	3 way valve VB3*	Controls the water flow path and the water flow rate.
Error Code	Error code	Error code.

Data before Error occurred Terminology (CMH-WM250/350/500V-A)

Mark	Official Name	Meaning
Time(min.sec)	Time(min.sec)	Time(min.sec) before error occurred
TH11	Thermistor	Liquid-side refrigerant temp. of heat exchanger
TH13	Thermistor	Gas-side refrigerant temp. of heat exchanger
TH32	Thermistor	Outlet water temp. of heat exchanger
TH35	Thermistor	Water pump discharge water temp.
THHS	Thermistor	Heat sink temperature
PWS(kPa)	Pressure sensor	Water pump suction water pressure
PWD(kPa)	Pressure sensor	Water pump discharge water pressure
Prf	Pressure sensor	Refrigerant pressure at heat exchanger
Trf	Saturation temperature of refrigerant	For control of LEV
SH	Superheat	Superheat at heat exchanger. TH13-Tref
SC	Subcool	Subcool at heat exchanger. Tref-TH11
PS	Power failure detection	Power failure detection
PumpO1	Pump1 Output	variable for control
Vdc	Pump1 bus voltage	Pump1 bus voltage [V]
Iu	U-Phase current effective value	U-Phase current effective value [A]
Iw	W-Phase current effective value	W-Phase current effective value [A]
Vdcgain	Vdcgain	Vdcgain
offset_u	offset_u	offset_u
offset_w	offset_w	offset_w
vf_ofst_pwr	vf_ofst_pwr	vf_ofst_pwr
HU Sig	Outdoor unit operation control	Outdoor unit operation control signal to OC
OC Sig	Indoor unit operation control	Indoor unit operation control signal from OC
QjC	Total capacity code (cooling)	Cooling indoor unit capacity
QjH	Total capacity code (heating)	Heating indoor unit capacity
SV1	Solenoid valve	Refrigerant flow volume control
LEV1	LEV1 opening	Heat exchanger capacity control
Error Code	Error code	Error code

Data before Error occurred Terminology (RBH-P35NRA-Q-TWN/RBS-P20/202HRA-Q-TWN)

Mark	Official Name	Meaning
MODEL CODE (Unit code)	-	06(STD08)
Ver	Software Version	Main program ROM version
TH1	Thermistor	Room temperature (Air temperature measured by thermistor)
TH2	End of defrosting1	Defrost end(1)/Other(0)
TH3	End of defrosting2	Defrost end(1)/Other(0)
TH4	Model(Unit) setting	Model setting input
THe	Analog input1	Blank
4-20	Analog input2	Blank
SET TEMP.	Room temperature setting	Target room temperature (Cut-off value)
RC COMMAND	Remote controler command	Operation(1)/Stop(0)
DATE	DATE(YMMDD)	A date when abnormalities occur
TIME	TIME	A time when abnormalities occur
DIFF.	Room temperature difference	Differential of room temperature ((Cut-in value) - (Cut-off value))
SETBACK	Setback value	Setting value of setback operation
TEMP ALARM	Difference of high temperature alarm	Setting value of high temperature alarm
X6	External abnormalities	Condensing unit is unusual(1)/usual(0)
X7	Compressor ON/OFF	One or more compressors are Running(1)/Stop(0)
IN3	External contact input	Set up(1)/Unset up(0)
IN4	(Reserve)	Blank
LEV	Linear expansion valve	Linear expansion valve output [pulse]
X1	Control source output	-
X2	Solenoid valve (liquid) output	-
X3	Cooler fan output	-
X4	Defrost heater output1	-
X5	Defrost heater output2	-
X30	Alarm output1	Condensing unit is unusual(1)/usual(0)
X31	Alarm output2	High temperature alarm(1)/usual(0)
X32	Alarm output3	High temperature error (50°C)(1)/usual(0)
12-1	Driver output1 (DC12V)	Warning buzzer output
12-2	Driver output2 (DC12V)	Blank
12-3	Driver output2 (DC12V)	Blank

Operation Status Monitor Terminology

(PUHY-P72/96/108TGMU-A, PUHY-P126/144TGMU-A, PUHY-P168/192/204/216/234TGMU-A)

Mark	Official Name	Meaning
Ctrl Mode		Control mode for outdoor unit
Ope Mode		Operation mode for outdoor unit
Save		Signal of capacity saving from system controller. figure : % No signal : 100%
Power	Power source frequency	Power source frequency (Hz)
F	Temporary compressor frequency for calculation	Variable for control
F1	Temporary compressor frequency of No.1 Comp for calculation	Variable for control (only for P168 type or over)
F2	Temporary compressor frequency of No.2 Comp for calculation	Variable for control (only for P168 type or over)
AK	Heat exchanger capacity	Variable which determines the size of outdoor heat exchanger
FAN	Fan	Fan capacity of outdoor unit (not proportional to rotational frequency)
DEMAND	ON/OFF demand	Input stop signal of compressor (ON:effective, OFF:ineffective)
DEMAND2	Intermediate demand	Signal of capacity saving (ON:effective, OFF:ineffective) DEMAND=OFF, DEMAND2=OFF: 100% DEMAND=OFF, DEMAND2=ON : 75% DEMAND= ON, DEMAND2=ON : 50% DEMAND= ON, DEMAND2=OFF: 25%
SNOW	Snow sensor	Input run signal of outdoor unit fan (As compressor stopped) (ON:effective, OFF:ineffective)
NIGHT	Night mode	Decreases frequency of outdoor unit fan (ON:effective, OFF:ineffective)
Qj(C)	Total capacity code (cool)	Cooling indoor unit capacity
Qj(H)	Total capacity code (heat)	Heating indoor unit capacity
LEV1	SC coil LEV opening	Adjusts refrigerant in the bypass pipe from liquid pipe in the outdoor unit in cooling mode.
21S4a	4-way valve	Switches the cooling/heating cycle (0:Cooling, 1:Heating)
21S4b	4-way valve	Capacity control of heat exchanger (Gas side) (only for P126 type or over)
SV1	Solenoid valve output (Bypass between discharge pipe and suction pipe)	The discharge pressure control
SV3	Solenoid valve output (Bypass between discharge pipe and suction pipe)	Protects compressor when No.2 compressor stops. (only for P168 type or over)
SV5b	Solenoid valve output	Capacity control of heat exchanger (Liquid side). (only for P126 type or over)
52F	Contactora	ON/OFF switch of No.2 fan (only for P168 type or over)
Rep	Repeater output	Prohibit(0)/Permit(1) the communication with centralized control system
TH11	Thermistor (Detects discharge temperature)	Detects discharge temperature for protection of No.1 compressor.
TH12	Thermistor (Detects discharge temperature)	Detects discharge temperature for protection of No.2 compressor. (only for P168 type or over)
TH5	Thermistor (Detects the liquid pipe temperature)	Controls defrosting (start/ end) in heating mode.
TH6	Thermistor (Detects the ambient air temperature)	Detects the ambient temperature and then, controls the fan frequency and liquid level in the accumulator.
TH7(8)	Thermistor (Controls SC)	Controls LEV1 based on the temperature differences between TH 6,7 and 8.
THHS1	Thermistor (Comp inverter radiator plate temperature)	Controls the Comp inverter cooling fan based on the THHS1 temperature.
THHS5	Thermistor (Fan inverter radiator plate temperature)	Controls the Fan inverter cooling fan based on the THHS5 temperature.
63HS	High pressure sensor	Detects the discharge pressure and then protects unit against da

		mage by high pressure.
63LS	Low pressure sensor	Detects the suction pressure and then, senses the refrigerant composition.
Tc	Average of saturation gas temperature of high pressure and saturation liquid temperature of high pressure	For control of compressor frequency and fan speed.
Te	Saturation temperature of low pressure	For control of compressor frequency and fan speed
SCO	Sub-cool at heat exchanger Tc-TH5	Variable for control
SCC	Sub-cool at SC coil exit Tc-TH7	Variable for control
SHB	SC coil bypass exit super heat TH8-Te	Variable for control
Vdc	Bus voltage	Bus voltage
Idc	DC trunk line current	DC trunk line current
Iu	Phase-U current	Phase-U current of compressor
Iw	Phase-W current	Phase-W current of compressor

Operation Status Monitor Terminology

(PURY-P72/96/108/126/144TGMU-A, PURY-P168/192/204/216/234TGMU-A)

Mark	Official Name	Meaning
Ctrl Mode		Control mode for outdoor unit
Ope Mode		Operation mode for outdoor unit
Save		Signal of capacity saving from system controller. figure : % No signal : 100%
Power	Power source frequency	Power source frequency (Hz)
F	Temporary compressor frequency for calculation	Variable for control
F1	Temporary compressor frequency of No.1 Comp for calculation	Variable for control (only for P168 type or over)
F2	Temporary compressor frequency of No.2 Comp for calculation	Variable for control (only for P168 type or over)
AK	Heat exchanger capacity	Variable which determines the size of outdoor heat exchanger
FAN	Fan	Fan capacity of outdoor unit (not proportional to rotational frequency)
DEMAND	ON/OFF demand	Input stop signal of compressor (ON:effective, OFF:ineffective)
DEMAND2	Intermediate demand	Signal of capacity saving (ON:effective OFF:ineffective) DEMAND=OFF, DEMAND2=OFF: 100% DEMAND=OFF, DEMAND2=ON : 75% DEMAND= ON, DEMAND2=ON : 50% DEMAND= ON, DEMAND2=OFF: 25%
SNOW	Snow sensor	Input run signal of outdoor unit fan (As compressor stopped) (ON:effective, OFF:ineffective)
NIGHT	Night mode	Decreases frequency of outdoor unit fan (ON:effective, OFF:ineffective)
Qj(C)	Total capacity code (cool)	Cooling indoor unit capacity
Qj(H)	Total capacity code (heat)	Heating indoor unit capacity
21S4a	4-way valve	Switches the cooling/heating cycle (0:Cooling, 1:Heating)
21S4b	4-way valve	Heat exchanger capacity control (only for P168 type or over)
SV1	Solenoid valve output	Bypass between discharge pipe and suction pipe
SV2	Solenoid valve output	Bypass between discharge pipe and suction pipe
SV3	Solenoid valve output	Bypass between discharge pipe and suction pipe (only for P168 type or over)
SV4a	Solenoid valve output	Heat exchanger capacity control
SV4b	Solenoid valve output	Heat exchanger capacity control
SV4c	Solenoid valve output	Heat exchanger capacity control
SV4d	Solenoid valve output	Heat exchanger bypass ON/OFF
SV5a	Solenoid valve output	Heat exchanger capacity control (only for P168 type or over)
SV5b	Solenoid valve output	Heat exchanger capacity control (only for P168 type or over)
52F	Contactora	ON/OFF switch of No.2 fan (only for P168 type or over)
Rep	Repeater output	Prohibit(0)/Permit(1) the communication with centralized control system
TH11	Thermistor (Detects discharge temperature)	Detects discharge temperature for protection of No.1 compressor.
TH12	Thermistor (Detects discharge temperature)	Detects discharge temperature for protection of No.2 compressor. (only for P168 type or over)
TH5	Thermistor (Detects the pipe temperature)	Controls defrosting (start/ end) in heating mode.
TH6	Thermistor (Detects the ambient air temperature)	Detects the ambient temperature and then, controls the fan frequency and liquid level in the accumulator.
TH7	Thermistor (Detects pipe temperature)	For defrost control
THHS1	Thermistor (Comp inverter radiator plate temperature)	Controls the Comp inverter cooling fan based on the THHS1 temperature.
THHS5	Thermistor (Fan inverter radiator plate temperature)	Controls the Fan inverter cooling fan based on the THHS5 temperature.

63HS	High pressure sensor	Detects the discharge pressure and then protects unit against damage by high pressure.
63LS	Low pressure sensor	Detects the suction pressure and then, protects unit against damage by low pressure.
Tc	Average of saturation gas temperature of high pressure and saturation liquid temperature of high pressure	For control of compressor frequency and fan speed.
Te	Saturation temperature of low pressure	For control of compressor frequency and fan speed.
Vdc	Bus voltage	Bus voltage
Idc	DC trunk line current	DC trunk line current
Iu	Phase-U current	Phase-U current of compressor
Iw	Phase-W current	Phase-W current of compressor

Operation Status Monitor Terminology (PQHY-P72/96TGMU-A)

Mark	Official Name	Meaning
Ctrl Mode		Control mode for outdoor unit
Ope Mode		Operation mode for outdoor unit
Save		Signal of capacity saving from system controller. figure : % No signal : 100%
Power	Power source frequency	Power source frequency (Hz)
F	Temporary compressor frequency for calculation	Variable for control
AK	Heat exchanger capacity	Variable which determines the size of outdoor heat exchanger
DEMAND	ON/OFF demand	Input stop signal of compressor (ON:effective, OFF:ineffective)
DEMAND2	Intermediate demand	Signal of capacity saving (ON:effective, OFF:ineffective) DEMAND=OFF, DEMAND2=OFF: 100% DEMAND=OFF, DEMAND2=ON : 75% DEMAND= ON, DEMAND2=ON : 50% DEMAND= ON, DEMAND2=OFF: 25%
NIGHT	Night mode	Decreases frequency of outdoor unit fan (ON:effective, OFF:ineffective)
Qj(C)	Total capacity code (cool)	Cooling indoor unit capacity
Qj(H)	Total capacity code (heat)	Heating indoor unit capacity
LEV1	SC coil LEV opening	Adjusts refrigerant in the bypass pipe from liquid pipe in the outdoor unit in cooling mode.
LEV2	Cool down inverter LEV opening	Cool down inverter
21S4a	4-way valve	Switches the cooling/heating cycle (0:Cooling, 1:Heating)
SV1	Solenoid valve output	Bypass between discharge pipe and suction pipe
SV4a	Solenoid valve output	Heat exchanger capacity control
SV4b	Solenoid valve output	Heat exchanger capacity control
SV4c	Solenoid valve output	Heat exchanger capacity control
SV4d	Solenoid valve output	Heat exchanger bypass ON/OFF
SV5a	Solenoid valve output	Heat exchanger capacity control (only for P400/500YSGM-A type)
SV5b	Solenoid valve output	Heat exchanger capacity control (only for P400/500YSGM-A type)
SV7a	Solenoid valve output	Heat exchanger capacity control
SV7b	Solenoid valve output	Heat exchanger capacity control
SV7c	Solenoid valve output	Heat exchanger capacity control
UNIT_ON/OFF	ON/OFF-output	ON/OFF-monitor (TB8-1,2P)
Rep	Repeater output	Prohibit(0)/Permit(1) the communication with centralized control system
TH11	Thermistor (Detects discharge temperature)	Detects discharge temperature for protection of No.1 compressor.
TH5	Thermistor (Detects the liquid pipe temperature)	Controls defrosting (start/ end) in heating mode.
TH6	Thermistor (Detects the ambient air temperature)	Detects the ambient temperature and then, controls the fan frequency and liquid level in the accumulator.
TH7(8)	Thermistor (Controls SC)	Controls LEV1 based on the temperature differences between TH 6,7 and 8.
TH9	Thermistor (Freeze prevention sensor)	Detects the water heat exchanger temperature and then, carries out freeze prevention control.
THINV	Thermistor (Outlet of heat exchanger for cool down inverter)	Controls a capacity of heat exchanger for cool down inverter depends on a temperature of THINV.
THHS1	Thermistor (Comp inverter radiator plate temperature)	Controls the Comp inverter cooling fan based on the THHS1 temperature.
63HS	High pressure sensor	Detects the discharge pressure and then protects unit against damage by high pressure.
63LS	Low pressure sensor	Detects the suction pressure and then, protects unit against damage by low pressure.
Tc	Average of saturation gas temperature of high pressure and saturation liquid temperature of high pressure	For control of compressor frequency and fan speed.
Te	Saturation temperature of low pressure	For control of compressor frequency and fan speed.

Vdc	Bus voltage	Bus voltage
Idc	DC trunk line current	DC trunk line current
Iu	Phase-U current	Phase-U current of compressor
Iw	Phase-W current	Phase-W current of compressor

Operation Status Monitor Terminology (PQRY-P72/96TGMU-A)

Mark	Official Name	Meaning
Ctrl Mode		Control mode for outdoor unit
Ope Mode		Operation mode for outdoor unit
Save		Signal of capacity saving from system controller. figure : % No signal : 100%
Power	Power source frequency	Power source frequency (Hz)
F	Temporary compressor frequency for calculation	Variable for control
AK	Heat exchanger capacity	Variable which determines the size of outdoor heat exchanger
DEMAND	ON/OFF demand	Input stop signal of compressor (ON:effective, OFF:ineffective)
DEMAND2	Intermediate demand	Signal of capacity saving (ON:effective, OFF:ineffective) DEMAND=OFF, DEMAND2=OFF: 100% DEMAND=OFF, DEMAND2=ON : 75% DEMAND= ON, DEMAND2=ON : 50% DEMAND= ON, DEMAND2=OFF: 25%
NIGHT	Night mode	Decreases frequency of outdoor unit fan (ON:effective, OFF:ineffective)
Qj(C)	Total capacity code (cool)	Cooling indoor unit capacity
Qj(H)	Total capacity code (heat)	Heating indoor unit capacity
LEV2	Cool down inverter LEV opening	Cool down inverter
21S4a	4-way valve	Switches the cooling/heating cycle (0:Cooling, 1:Heating)
SV1	Solenoid valve output	Bypass between discharge pipe and suction pipe
SV4a	Solenoid valve output	Heat exchanger capacity control
SV4b	Solenoid valve output	Heat exchanger capacity control
SV4c	Solenoid valve output	Heat exchanger capacity control
SV4d	Solenoid valve output	Heat exchanger bypass ON/OFF
SV5a	Solenoid valve output	Heat exchanger capacity control (only for P400/500YSGM-A type)
SV5b	Solenoid valve output	Heat exchanger capacity control (only for P400/500YSGM-A type)
SV7a	Solenoid valve output	Heat exchanger capacity control
SV7b	Solenoid valve output	Heat exchanger capacity control
SV7c	Solenoid valve output	Heat exchanger capacity control
UNIT_ON/OFF	ON/OFF-output	ON/OFF-monitor (TB8-1,2P)
Rep	Repeater output	Prohibit(0)/Permit(1) the communication with centralized control system
TH11	Thermistor (Detects discharge temperature)	Detects discharge temperature for protection of No.1 compressor.
TH6	Thermistor (Detects the ambient air temperature)	Detects the ambient temperature and then, controls the fan frequency and liquid level in the accumulator.
TH9	Thermistor (Freeze prevention sensor)	Detects the water heat exchanger temperature and then, carries out freeze prevention control.
THINV	Thermistor (Outlet of heat exchanger for cool down inverter)	Controls a capacity of heat exchanger for cool down inverter depends on a temperature of THINV.
THHS1	Thermistor (Comp inverter radiator plate temperature)	Controls the Comp inverter cooling fan based on the THHS1 temperature.
63HS	High pressure sensor	Detects the discharge pressure and then protects unit against damage by high pressure.
63LS	Low pressure sensor	Detects the suction pressure and then, protects unit against damage by low pressure.
Tc	Average of saturation gas temperature of high pressure and saturation liquid temperature of high pressure	For control of compressor frequency and fan speed.
Te	Saturation temperature of low pressure	For control of compressor frequency and fan speed.
Vdc	Bus voltage	Bus voltage
Idc	DC trunk line current	DC trunk line current
Iu	Phase-U current	Phase-U current of compressor
Iw	Phase-W current	Phase-W current of compressor

Operation Status Monitor Terminology (PUMY-P100/125/140YHM)

<Notes on monitoring the PUMY series units with the Maintenance Tool>

When monitoring the PUMY series of outdoor units with the Maintenance Tool, indeterminate values will appear as the sensor values for models without built-in sensors. See the manuals of the respective models for the presence or absence of sensors.

Mark	Official Name	Meaning
Operation mode		Operation mode
FAN	Fan steps	Out door unit fan steps
F/Hz	Compressor frequency	Compressor frequency
SC	Sub cool	Sub cool
SCm	Target sub cool	Target sub cool (cooling)
Pdm	Target high pressure	Target high pressure (heating)
ETm	Target evaporation temperature	Target evaporation temperature (cooling)
52C	electromagnetic contactor	52C output (inverter main circuit)
21S4	4-way valve	4-way valve
SV1(A)	Solenoid valve 1 output	The bypass of discharge gas (for pd back up)
SV1(B)	Solenoid valve 1 output	The bypass of discharge gas(for td back up)
SV1(C)	Solenoid valve 1 output	The bypass of discharge gas(for stop mode pressure equalization)
TH4	Thermistor (Detects discharge temperature)	It detects the discharge temperature to control the compressor frequency. It protects the discharge temperature. It is used to calculate the discharge superheat temperature.
TH6	Thermistor	It detects the low pressure saturation temperature to control the compressor frequency.
TH3	Thermistor (Pipe temperature/Defrost determination)	It is used to control LEV pulse in cooling mode. It is used to start the defrost mode in heating mode.
TH7	Thermistor (Detects the ambient air temperature)	It detects the ambient temperature to control outdoor fan and LEV pulse.
TH8	Thermistor (radiator plate temperature)	It detects the power transistor radiator plate temperature for protection of power transistor.
63HS	High pressure sensor	It detects the discharge pressure to control the compressor frequency and protects unit against damage by high pressure. It is used to calculate the sub cool. (Detects discharge pressure)
SC 1	Sub cool of indoor unit 1	Heating mode:Sub cool of indoor unit 1
SC 2	Sub cool of indoor unit 2	Heating mode:Sub cool of indoor unit 2
SC 3	Sub cool of indoor unit 3	Heating mode:Sub cool of indoor unit 3
SC 4	Sub cool of indoor unit 4	Heating mode:Sub cool of indoor unit 4
SC 5	Sub cool of indoor unit 5	Heating mode:Sub cool of indoor unit 5
SC 6	Sub cool of indoor unit 6	Heating mode:Sub cool of indoor unit 6
SC 7	Sub cool of indoor unit 7	Heating mode:Sub cool of indoor unit 7
SC 8	Sub cool of indoor unit 8	Heating mode:Sub cool of indoor unit 8
SC 9	Sub cool of indoor unit 9	Heating mode:Sub cool of indoor unit 9
SC10	Sub cool of indoor unit 10	Heating mode:Sub cool of indoor unit 10
SC11	Sub cool of indoor unit 11	Heating mode:Sub cool of indoor unit 11
SC12	Sub cool of indoor unit 12	Heating mode:Sub cool of indoor unit 12
SCm 1	Target sub cool of indoor unit 1	Heating mode:Target sub cool of indoor unit 1
SCm 2	Target sub cool of indoor unit 2	Heating mode:Target sub cool of indoor unit 2
SCm 3	Target sub cool of indoor unit 3	Heating mode:Target sub cool of indoor unit 3
SCm 4	Target sub cool of indoor unit 4	Heating mode:Target sub cool of indoor unit 4
SCm 5	Target sub cool of indoor unit 5	Heating mode:Target sub cool of indoor unit 5
SCm 6	Target sub cool of indoor unit 6	Heating mode:Target sub cool of indoor unit 6
SCm 7	Target sub cool of indoor unit 7	Heating mode:Target sub cool of indoor unit 7
SCm 8	Target sub cool of indoor unit 8	Heating mode:Target sub cool of indoor unit 8
SCm 9	Target sub cool of indoor unit 9	Heating mode:Target sub cool of indoor unit 9
SCm10	Target sub cool of indoor unit 10	Heating mode:Target sub cool of indoor unit 10
SCm11	Target sub cool of indoor unit 11	Heating mode:Target sub cool of indoor unit 11
SCm12	Target sub cool of indoor unit 12	Heating mode:Target sub cool of indoor unit 12

	it 12	
LEV 1	LEV pulse of indoor unit 1	LEV pulse of indoor unit 1 LEV pulse control from the outdoor unit
LEV 2	LEV pulse of indoor unit 2	LEV pulse of indoor unit 2 LEV pulse control from the outdoor unit
LEV 3	LEV pulse of indoor unit 3	LEV pulse of indoor unit 3 LEV pulse control from the outdoor unit
LEV 4	LEV pulse of indoor unit 4	LEV pulse of indoor unit 4 LEV pulse control from the outdoor unit
LEV 5	LEV pulse of indoor unit 5	LEV pulse of indoor unit 5 LEV pulse control from the outdoor unit
LEV 6	LEV pulse of indoor unit 6	LEV pulse of indoor unit 6 LEV pulse control from the outdoor unit
LEV 7	LEV pulse of indoor unit 7	LEV pulse of indoor unit 7 LEV pulse control from the outdoor unit
LEV 8	LEV pulse of indoor unit 8	LEV pulse of indoor unit 8 LEV pulse control from the outdoor unit
LEV 9	LEV pulse of indoor unit 9	LEV pulse of indoor unit 9 LEV pulse control from the outdoor unit
LEV10	LEV pulse of indoor unit 10	LEV pulse of indoor unit 10 LEV pulse control from the outdoor unit
LEV11	LEV pulse of indoor unit 11	LEV pulse of indoor unit 11 LEV pulse control from the outdoor unit
LEV12	LEV pulse of indoor unit 12	LEV pulse of indoor unit 12 LEV pulse control from the outdoor unit
INPUT CURRENT	INPUT CURRENT	Input current of outdoor unit.
COMP CURRENT	COMPRESSOR CURRENT	Compressor operating current of outdoor unit.
VDC	BUS BAR VOLTAGE(V)	Bus bar voltage of inverter circuit

Operation Status Monitor Terminology (PUMY-P36/48NHMUR4)

<Notes on monitoring the PUMY series units with the Maintenance Tool>

When monitoring the PUMY series of outdoor units with the Maintenance Tool, indeterminate values will appear as the sensor values for models without built-in sensors. See the manuals of the respective models for the presence or absence of sensors.

Mark	Official Name	Meaning
Operation mode		Operation mode
F/Hz	Compressor frequency	Compressor frequency
FAN	Fan steps	Out door unit fan steps
VDC	BUS BAR VOLTAGE(V)	Bus bar voltage of inverter circuit
LEV_A	LEV-A pulse of outdoor unit (not implemented)	Command value of LEV-A pulse of outdoor unit (fixed to blank)
LEV_B	LEV-B pulse of outdoor unit (not implemented)	Command value of LEV-B pulse of outdoor unit (fixed to blank)
52C	electromagnetic contactor	52C output (inverter main circuit)
21S4	4-way valve	4-way valve
SV1(A)	Solenoid valve 1 output	The bypass of discharge gas (for pd back up)
SV1(B)	Solenoid valve 1 output	The bypass of discharge gas(for td back up)
SV1(C)	Solenoid valve 1 output	The bypass of discharge gas(for stop mode pressure equalization)
demand	A state of demand function via outdoor unit input	Input: 1 / No input: 0
TH4	Thermistor (Detects comp. surface temperature)	It detects the comp. surface temperature to control the compressor frequency. It protects the comp. surface temperature. It is used to calculate the discharge superheat temperature.
TH6	Thermistor	It detects the low pressure saturation temperature to control the compressor frequency.
TH3	Thermistor (Pipe temperature/Defrost determination)	It is used to control LEV pulse in cooling mode. It is used to start the defrost mode in heating mode.
TH7	Thermistor (Detects the ambient air temperature)	It detects the ambient temperature to control outdoor fan and LEV pulse.
TH8	Thermistor (radiator plate temperature)	It detects the power transistor radiator plate temperature for protection of power transistor.
63HS	High pressure sensor	It detects the discharge pressure to control the compressor frequency and protects unit against damage by high pressure. It is used to calculate the sub cool. (Detects discharge pressure)
63LS	Low pressure sensor (not implemented)	It detects the suction pressure to control LEV-B and LEVs of indoor units pulse. (fixed to 0.0)
TH2	Thermistor (not implemented) (HIC temperature)	It is used to control LEV-B pulse. (fixed to 0.0)
SC	Sub cool	Sub cool
SCm	Target sub cool	Target sub cool (cooling)
Pdm	Target high pressure	Target high pressure (heating)
ETm	Target evaporation temperature	Target evaporation temperature (cooling)
I(input)(A)	Input current	Input current of outdoor unit.
I(comp)(A)	Compressor current	Compressor operating current of outdoor unit.
SC 1	Sub cool of indoor unit 1	Heating mode:Sub cool of indoor unit 1
SC 2	Sub cool of indoor unit 2	Heating mode:Sub cool of indoor unit 2
SC 3	Sub cool of indoor unit 3	Heating mode:Sub cool of indoor unit 3
SC 4	Sub cool of indoor unit 4	Heating mode:Sub cool of indoor unit 4
SC 5	Sub cool of indoor unit 5	Heating mode:Sub cool of indoor unit 5
SC 6	Sub cool of indoor unit 6	Heating mode:Sub cool of indoor unit 6
SC 7	Sub cool of indoor unit 7	Heating mode:Sub cool of indoor unit 7
SC 8	Sub cool of indoor unit 8	Heating mode:Sub cool of indoor unit 8
SC 9	Sub cool of indoor unit 9	Heating mode:Sub cool of indoor unit 9
SC10	Sub cool of indoor unit 10	Heating mode:Sub cool of indoor unit 10
SC11	Sub cool of indoor unit 11	Heating mode:Sub cool of indoor unit 11
SC12	Sub cool of indoor unit 12	Heating mode:Sub cool of indoor unit 12
SCm 1	Target sub cool of indoor unit 1	Heating mode:Target sub cool of indoor unit 1
SCm 2	Target sub cool of indoor unit 2	Heating mode:Target sub cool of indoor unit 2
SCm 3	Target sub cool of indoor unit 3	Heating mode:Target sub cool of indoor unit 3
SCm 4	Target sub cool of indoor unit 4	Heating mode:Target sub cool of indoor unit 4
SCm 5	Target sub cool of indoor unit 5	Heating mode:Target sub cool of indoor unit 5

SCm 6	Target sub cool of indoor unit 6	Heating mode:Target sub cool of indoor unit 6
SCm 7	Target sub cool of indoor unit 7	Heating mode:Target sub cool of indoor unit 7
SCm 8	Target sub cool of indoor unit 8	Heating mode:Target sub cool of indoor unit 8
SCm 9	Target sub cool of indoor unit 9	Heating mode:Target sub cool of indoor unit 9
SCm10	Target sub cool of indoor unit 10	Heating mode:Target sub cool of indoor unit 10
SCm11	Target sub cool of indoor unit 11	Heating mode:Target sub cool of indoor unit 11
SCm12	Target sub cool of indoor unit 12	Heating mode:Target sub cool of indoor unit 12
LEV 1	LEV pulse of indoor unit 1	LEV pulse of indoor unit 1 LEV pulse control from the outdoor unit
LEV 2	LEV pulse of indoor unit 2	LEV pulse of indoor unit 2 LEV pulse control from the outdoor unit
LEV 3	LEV pulse of indoor unit 3	LEV pulse of indoor unit 3 LEV pulse control from the outdoor unit
LEV 4	LEV pulse of indoor unit 4	LEV pulse of indoor unit 4 LEV pulse control from the outdoor unit
LEV 5	LEV pulse of indoor unit 5	LEV pulse of indoor unit 5 LEV pulse control from the outdoor unit
LEV 6	LEV pulse of indoor unit 6	LEV pulse of indoor unit 6 LEV pulse control from the outdoor unit
LEV 7	LEV pulse of indoor unit 7	LEV pulse of indoor unit 7 LEV pulse control from the outdoor unit
LEV 8	LEV pulse of indoor unit 8	LEV pulse of indoor unit 8 LEV pulse control from the outdoor unit
LEV 9	LEV pulse of indoor unit 9	LEV pulse of indoor unit 9 LEV pulse control from the outdoor unit
LEV10	LEV pulse of indoor unit 10	LEV pulse of indoor unit 10 LEV pulse control from the outdoor unit
LEV11	LEV pulse of indoor unit 11	LEV pulse of indoor unit 11 LEV pulse control from the outdoor unit
LEV12	LEV pulse of indoor unit 12	LEV pulse of indoor unit 12 LEV pulse control from the outdoor unit

Operation Status Monitor Terminology (PUMY-P60NKMU)

<Notes on monitoring the PUMY series units with the Maintenance Tool>

When monitoring the PUMY series of outdoor units with the Maintenance Tool, indeterminate values will appear as the sensor values for models without built-in sensors. See the manuals of the respective models for the presence or absence of sensors.

Mark	Official Name	Meaning
Operation mode		Operation mode
F/Hz	Compressor frequency	Compressor frequency
FAN	Fan steps	Out door unit fan steps
VDC	BUS BAR VOLTAGE(V)	Bus bar voltage of inverter circuit
LEV_A	LEV-A pulse of outdoor unit	Command value of LEV-A pulse of outdoor unit (fixed to blank)
LEV_B	LEV-B pulse of outdoor unit	Command value of LEV-B pulse of outdoor unit (fixed to blank)
52C	electromagnetic contactor	52C output (inverter main circuit)
21S4	4-way valve	4-way valve
SV1	Solenoid valve 1 output	Bypass valve for discharge gas
SV2	Solenoid valve 2 output	Switching valve for refrigerant circuit
SV3	Solenoid valve 3 output	Oil return valve
demand	A state of demand function via outdoor unit input	Input: 1 / No input: 0
TH4	Thermistor (Detects comp. surface temperature)	It detects the comp. surface temperature to control the compressor frequency. It protects the comp. surface temperature. It is used to calculate the discharge superheat temperature.
TH6	Thermistor	It detects the low pressure saturation temperature to control the compressor frequency.
TH3	Thermistor (Pipe temperature/Defrost determination)	It is used to control LEV pulse in cooling mode. It is used to start the defrost mode in heating mode.
TH7	Thermistor (Detects the ambient air temperature)	It detects the ambient temperature to control outdoor fan and LEV pulse.
TH8	Thermistor (radiator plate temperature)	It detects the power transistor radiator plate temperature for protection of power transistor.
63HS	High pressure sensor	It detects the discharge pressure to control the compressor frequency and protects unit against damage by high pressure. It is used to calculate the sub cool. (Detects discharge pressure)
63LS	Low pressure sensor	It detects the suction pressure to control LEV-B and LEVs of indoor units pulse.
TH2	Thermistor (HIC temperature)	It is used to control LEV-B pulse.
SC	Sub cool	Sub cool
SCm	Target sub cool	Target sub cool (cooling)
Pdm	Target high pressure	Target high pressure (heating)
ETm	Target evaporation temperature	Target evaporation temperature (cooling)
I(input)(A)	Input current	Input current of outdoor unit.
I(comp)(A)	Compressor current	Compressor operating current of outdoor unit.
SC 1	Sub cool of indoor unit 1	Heating mode:Sub cool of indoor unit 1
SC 2	Sub cool of indoor unit 2	Heating mode:Sub cool of indoor unit 2
SC 3	Sub cool of indoor unit 3	Heating mode:Sub cool of indoor unit 3
SC 4	Sub cool of indoor unit 4	Heating mode:Sub cool of indoor unit 4
SC 5	Sub cool of indoor unit 5	Heating mode:Sub cool of indoor unit 5
SC 6	Sub cool of indoor unit 6	Heating mode:Sub cool of indoor unit 6
SC 7	Sub cool of indoor unit 7	Heating mode:Sub cool of indoor unit 7
SC 8	Sub cool of indoor unit 8	Heating mode:Sub cool of indoor unit 8
SC 9	Sub cool of indoor unit 9	Heating mode:Sub cool of indoor unit 9
SC10	Sub cool of indoor unit 10	Heating mode:Sub cool of indoor unit 10
SC11	Sub cool of indoor unit 11	Heating mode:Sub cool of indoor unit 11
SC12	Sub cool of indoor unit 12	Heating mode:Sub cool of indoor unit 12
SCm 1	Target sub cool of indoor unit 1	Heating mode:Target sub cool of indoor unit 1
SCm 2	Target sub cool of indoor unit 2	Heating mode:Target sub cool of indoor unit 2
SCm 3	Target sub cool of indoor unit 3	Heating mode:Target sub cool of indoor unit 3
SCm 4	Target sub cool of indoor unit 4	Heating mode:Target sub cool of indoor unit 4
SCm 5	Target sub cool of indoor unit 5	Heating mode:Target sub cool of indoor unit 5
SCm 6	Target sub cool of indoor unit 6	Heating mode:Target sub cool of indoor unit 6

SCm 7	Target sub cool of indoor unit 7	Heating mode:Target sub cool of indoor unit 7
SCm 8	Target sub cool of indoor unit 8	Heating mode:Target sub cool of indoor unit 8
SCm 9	Target sub cool of indoor unit 9	Heating mode:Target sub cool of indoor unit 9
SCm10	Target sub cool of indoor unit 10	Heating mode:Target sub cool of indoor unit 10
SCm11	Target sub cool of indoor unit 11	Heating mode:Target sub cool of indoor unit 11
SCm12	Target sub cool of indoor unit 12	Heating mode:Target sub cool of indoor unit 12
LEV 1	LEV pulse of indoor unit 1	LEV pulse of indoor unit 1 LEV pulse control from the outdoor unit
LEV 2	LEV pulse of indoor unit 2	LEV pulse of indoor unit 2 LEV pulse control from the outdoor unit
LEV 3	LEV pulse of indoor unit 3	LEV pulse of indoor unit 3 LEV pulse control from the outdoor unit
LEV 4	LEV pulse of indoor unit 4	LEV pulse of indoor unit 4 LEV pulse control from the outdoor unit
LEV 5	LEV pulse of indoor unit 5	LEV pulse of indoor unit 5 LEV pulse control from the outdoor unit
LEV 6	LEV pulse of indoor unit 6	LEV pulse of indoor unit 6 LEV pulse control from the outdoor unit
LEV 7	LEV pulse of indoor unit 7	LEV pulse of indoor unit 7 LEV pulse control from the outdoor unit
LEV 8	LEV pulse of indoor unit 8	LEV pulse of indoor unit 8 LEV pulse control from the outdoor unit
LEV 9	LEV pulse of indoor unit 9	LEV pulse of indoor unit 9 LEV pulse control from the outdoor unit
LEV10	LEV pulse of indoor unit 10	LEV pulse of indoor unit 10 LEV pulse control from the outdoor unit
LEV11	LEV pulse of indoor unit 11	LEV pulse of indoor unit 11 LEV pulse control from the outdoor unit
LEV12	LEV pulse of indoor unit 12	LEV pulse of indoor unit 12 LEV pulse control from the outdoor unit

Operation Status Monitor Terminology (MXZ-8C48NA, MXZ-4C36/5C42/8C48NAHZ, MXZ-8C60NA-U1)

Mark	Official Name	Meaning
Operation mode		Operation mode
F/Hz	Compressor frequency	Compressor frequency
FAN	Fan steps	Out door unit fan steps
VDC	BUS BAR VOLTAGE(V)	Bus bar voltage of inverter circuit
LEV_A	LEV-A pulse of outdoor unit	Command value of LEV-A pulse of outdoor unit
LEV_B	LEV-B pulse of outdoor unit	Command value of LEV-B pulse of outdoor unit
52C	electromagnetic contactor	52C output (inverter main circuit)
21S4	4-way valve	4-way valve
SV1	Solenoid valve 1 output	Bypass valve for discharge gas
SV2	Solenoid valve 2 output	Switching valve for refrigerant circuit
SV3	Solenoid valve 3 output	Oil return valve
demand	A state of demand function via outdoor unit input	Input: 1 / No input: 0
TH4	Thermistor (Detects comp. surface temperature)	It detects the comp. surface temperature to control the compressor frequency. It protects the comp. surface temperature. It is used to calculate the discharge superheat temperature.
TH6	Thermistor	It detects the low pressure saturation temperature to control the compressor frequency.
TH3	Thermistor (Pipe temperature/Defrost determination)	It is used to control LEV pulse in cooling mode. It is used to start the defrost mode in heating mode.
TH7	Thermistor (Detects the ambient air temperature)	It detects the ambient temperature to control outdoor fan and LEV pulse.
TH8	Thermistor (radiator plate temperature)	It detects the power transistor radiator plate temperature for protection of power transistor.
63HS	High pressure sensor	It detects the discharge pressure to control the compressor frequency and protects unit against damage by high pressure. It is used to calculate the sub cool. (Detects discharge pressure)
63LS	Low pressure sensor	It detects the suction pressure to control LEV-B and LEVs of indoor units pulse.
TH2	Thermistor (HIC temperature)	It is used to control LEV-B pulse.
SC	Sub cool	Sub cool
SCm	Target sub cool	Target sub cool (cooling)
Pdm	Target high pressure	Target high pressure (heating)
ETm	Target evaporation temperature	Target evaporation temperature (cooling)
I(input)(A)	Input current	Input current of outdoor unit.
I(comp)(A)	Compressor current	Compressor operating current of outdoor unit.
SC 1	Sub cool of indoor unit 1	Heating mode:Sub cool of indoor unit 1
SC 2	Sub cool of indoor unit 2	Heating mode:Sub cool of indoor unit 2
SC 3	Sub cool of indoor unit 3	Heating mode:Sub cool of indoor unit 3
SC 4	Sub cool of indoor unit 4	Heating mode:Sub cool of indoor unit 4
SC 5	Sub cool of indoor unit 5	Heating mode:Sub cool of indoor unit 5
SC 6	Sub cool of indoor unit 6	Heating mode:Sub cool of indoor unit 6
SC 7	Sub cool of indoor unit 7	Heating mode:Sub cool of indoor unit 7
SC 8	Sub cool of indoor unit 8	Heating mode:Sub cool of indoor unit 8
SC 9	Sub cool of indoor unit 9	Heating mode:Sub cool of indoor unit 9
SC10	Sub cool of indoor unit 10	Heating mode:Sub cool of indoor unit 10
SC11	Sub cool of indoor unit 11	Heating mode:Sub cool of indoor unit 11
SC12	Sub cool of indoor unit 12	Heating mode:Sub cool of indoor unit 12
SCm 1	Target sub cool of indoor unit 1	Heating mode:Target sub cool of indoor unit 1
SCm 2	Target sub cool of indoor unit 2	Heating mode:Target sub cool of indoor unit 2
SCm 3	Target sub cool of indoor unit 3	Heating mode:Target sub cool of indoor unit 3
SCm 4	Target sub cool of indoor unit 4	Heating mode:Target sub cool of indoor unit 4
SCm 5	Target sub cool of indoor unit 5	Heating mode:Target sub cool of indoor unit 5
SCm 6	Target sub cool of indoor unit 6	Heating mode:Target sub cool of indoor unit 6
SCm 7	Target sub cool of indoor unit 7	Heating mode:Target sub cool of indoor unit 7
SCm 8	Target sub cool of indoor unit 8	Heating mode:Target sub cool of indoor unit 8

SCm 9	Target sub cool of indoor unit 9	Heating mode:Target sub cool of indoor unit 9
SCm10	Target sub cool of indoor unit 10	Heating mode:Target sub cool of indoor unit 10
SCm11	Target sub cool of indoor unit 11	Heating mode:Target sub cool of indoor unit 11
SCm12	Target sub cool of indoor unit 12	Heating mode:Target sub cool of indoor unit 12
LEV 1	LEV pulse of indoor unit 1	LEV pulse of indoor unit 1 LEV pulse control from the outdoor unit
LEV 2	LEV pulse of indoor unit 2	LEV pulse of indoor unit 2 LEV pulse control from the outdoor unit
LEV 3	LEV pulse of indoor unit 3	LEV pulse of indoor unit 3 LEV pulse control from the outdoor unit
LEV 4	LEV pulse of indoor unit 4	LEV pulse of indoor unit 4 LEV pulse control from the outdoor unit
LEV 5	LEV pulse of indoor unit 5	LEV pulse of indoor unit 5 LEV pulse control from the outdoor unit
LEV 6	LEV pulse of indoor unit 6	LEV pulse of indoor unit 6 LEV pulse control from the outdoor unit
LEV 7	LEV pulse of indoor unit 7	LEV pulse of indoor unit 7 LEV pulse control from the outdoor unit
LEV 8	LEV pulse of indoor unit 8	LEV pulse of indoor unit 8 LEV pulse control from the outdoor unit
LEV 9	LEV pulse of indoor unit 9	LEV pulse of indoor unit 9 LEV pulse control from the outdoor unit
LEV10	LEV pulse of indoor unit 10	LEV pulse of indoor unit 10 LEV pulse control from the outdoor unit
LEV11	LEV pulse of indoor unit 11	LEV pulse of indoor unit 11 LEV pulse control from the outdoor unit
LEV12	LEV pulse of indoor unit 12	LEV pulse of indoor unit 12 LEV pulse control from the outdoor unit

Operation Status Monitor Terminology (PUMY-P36/48NKMU, PUMY-HP36/48NKMU)

<Notes on monitoring the PUMY series units with the Maintenance Tool>

When monitoring the PUMY series of outdoor units with the Maintenance Tool, indeterminate values will appear as the sensor values for models without built-in sensors. See the manuals of the respective models for the presence or absence of sensors.

Mark	Official Name	Meaning
Operation mode		Operation mode
F/Hz	Compressor frequency	Compressor frequency
FAN	Fan steps	Out door unit fan steps
VDC	BUS BAR VOLTAGE(V)	Bus bar voltage of inverter circuit
LEV_A	LEV-A pulse of outdoor unit	Command value of LEV-A pulse of outdoor unit
LEV_B	LEV-B pulse of outdoor unit	Command value of LEV-B pulse of outdoor unit
52C	electromagnetic contactor	52C output (inverter main circuit)
21S4	4-way valve	4-way valve
SV1	Solenoid valve 1 output	Bypass valve for discharge gas
SV2	Solenoid valve 2 output	Switching valve for refrigerant circuit
SV3	Solenoid valve 3 output	Oil return valve
demand	A state of demand function via outdoor unit input	Input: 1 / No input: 0
TH4	Thermistor (Detects comp. surface temperature)	It detects the comp. surface temperature to control the compressor frequency. It protects the comp. surface temperature. It is used to calculate the discharge superheat temperature.
TH6	Thermistor	It detects the low pressure saturation temperature to control the compressor frequency.
TH3	Thermistor (Pipe temperature/Defrost determination)	It is used to control LEV pulse in cooling mode. It is used to start the defrost mode in heating mode.
TH7	Thermistor (Detects the ambient air temperature)	It detects the ambient temperature to control outdoor fan and LEV pulse.
TH8	Thermistor (radiator plate temperature)	It detects the power transistor radiator plate temperature for protection of power transistor.
63HS	High pressure sensor	It detects the discharge pressure to control the compressor frequency and protects unit against damage by high pressure. It is used to calculate the sub cool. (Detects discharge pressure)
63LS	Low pressure sensor	It detects the suction pressure to control LEV-B and LEVs of indoor units pulse.
TH2	Thermistor (HIC temperature)	It is used to control LEV-B pulse.
SC	Sub cool	Sub cool
SCm	Target sub cool	Target sub cool (cooling)
Pdm	Target high pressure	Target high pressure (heating)
ETm	Target evaporation temperature	Target evaporation temperature (cooling)
I(input)(A)	Input current	Input current of outdoor unit.
I(comp)(A)	Compressor current	Compressor operating current of outdoor unit.
SC 1	Sub cool of indoor unit 1	Heating mode:Sub cool of indoor unit 1
SC 2	Sub cool of indoor unit 2	Heating mode:Sub cool of indoor unit 2
SC 3	Sub cool of indoor unit 3	Heating mode:Sub cool of indoor unit 3
SC 4	Sub cool of indoor unit 4	Heating mode:Sub cool of indoor unit 4
SC 5	Sub cool of indoor unit 5	Heating mode:Sub cool of indoor unit 5
SC 6	Sub cool of indoor unit 6	Heating mode:Sub cool of indoor unit 6
SC 7	Sub cool of indoor unit 7	Heating mode:Sub cool of indoor unit 7
SC 8	Sub cool of indoor unit 8	Heating mode:Sub cool of indoor unit 8
SC 9	Sub cool of indoor unit 9	Heating mode:Sub cool of indoor unit 9
SC10	Sub cool of indoor unit 10	Heating mode:Sub cool of indoor unit 10
SC11	Sub cool of indoor unit 11	Heating mode:Sub cool of indoor unit 11
SC12	Sub cool of indoor unit 12	Heating mode:Sub cool of indoor unit 12
SCm 1	Target sub cool of indoor unit 1	Heating mode:Target sub cool of indoor unit 1
SCm 2	Target sub cool of indoor unit 2	Heating mode:Target sub cool of indoor unit 2
SCm 3	Target sub cool of indoor unit 3	Heating mode:Target sub cool of indoor unit 3
SCm 4	Target sub cool of indoor unit 4	Heating mode:Target sub cool of indoor unit 4
SCm 5	Target sub cool of indoor unit 5	Heating mode:Target sub cool of indoor unit 5
SCm 6	Target sub cool of indoor unit 6	Heating mode:Target sub cool of indoor unit 6
SCm 7	Target sub cool of indoor unit 7	Heating mode:Target sub cool of indoor unit 7

	it 7	
SCm 8	Target sub cool of indoor unit 8	Heating mode:Target sub cool of indoor unit 8
SCm 9	Target sub cool of indoor unit 9	Heating mode:Target sub cool of indoor unit 9
SCm10	Target sub cool of indoor unit 10	Heating mode:Target sub cool of indoor unit 10
SCm11	Target sub cool of indoor unit 11	Heating mode:Target sub cool of indoor unit 11
SCm12	Target sub cool of indoor unit 12	Heating mode:Target sub cool of indoor unit 12
LEV 1	LEV pulse of indoor unit 1	LEV pulse of indoor unit 1 LEV pulse control from the outdoor unit
LEV 2	LEV pulse of indoor unit 2	LEV pulse of indoor unit 2 LEV pulse control from the outdoor unit
LEV 3	LEV pulse of indoor unit 3	LEV pulse of indoor unit 3 LEV pulse control from the outdoor unit
LEV 4	LEV pulse of indoor unit 4	LEV pulse of indoor unit 4 LEV pulse control from the outdoor unit
LEV 5	LEV pulse of indoor unit 5	LEV pulse of indoor unit 5 LEV pulse control from the outdoor unit
LEV 6	LEV pulse of indoor unit 6	LEV pulse of indoor unit 6 LEV pulse control from the outdoor unit
LEV 7	LEV pulse of indoor unit 7	LEV pulse of indoor unit 7 LEV pulse control from the outdoor unit
LEV 8	LEV pulse of indoor unit 8	LEV pulse of indoor unit 8 LEV pulse control from the outdoor unit
LEV 9	LEV pulse of indoor unit 9	LEV pulse of indoor unit 9 LEV pulse control from the outdoor unit
LEV10	LEV pulse of indoor unit 10	LEV pulse of indoor unit 10 LEV pulse control from the outdoor unit
LEV11	LEV pulse of indoor unit 11	LEV pulse of indoor unit 11 LEV pulse control from the outdoor unit
LEV12	LEV pulse of indoor unit 12	LEV pulse of indoor unit 12 LEV pulse control from the outdoor unit

Operation Status Monitor Terminology (PUHY - 200/250YM*)

Mark	Official Name	Meaning
Control mode		Control mode for outdoor unit
Operation mode		Operation mode for outdoor unit
F/	"Temporary compressor frequency for calculation"	Variable for control
Hz	Compressor frequency	Compressor frequency
AK	Heat exchanger capacity	Variable which determine the size of outdoor heat exchanger
AL	Accumulator level	"Liquid level in the accumulation (0 :Undercharge, 1: Adequate, 2 :Overcharge)"
FAN	Fan	"Fan capacity of outdoor unit (not proportional to rotational frequency)"
SCO	Sub-cool at heat exchanger	Variable for control
SCC	Sub-cool at SC coil exit	Variable for control
SHB	SC coil bypass exit Supper heat	Variable for control
Qj(C)	Total capacity code (cool)	Cooling indoor unit capacity
Qj(H)	Total capacity code (heat)	Heating indoor unit capacity
SLEV	Oil return LEV opening	Adjusts the amount of liquid refrigerant and oil returned from the accumulator
LEV1	SC coil LEV opening	Adjusts refrigerant in the bypass pipe from liquid pipe in the outdoor unit in cooling mode.
21S4	4-way valve	Switches the cooling/heating cycle
SV1	Solenoid valve output (Bypass between discharge pipe and suction pipe)	Returns oil from the oil separator Restricts the rise in the discharge pressure
SV2	Solenoid valve output (Capacity control full load)	Switches the capacity control valve inside the compressor
SV3	Solenoid valve output (Capacity control unload)	Switches the capacity control valve inside the compressor
SV4	Solenoid valve output (Bypass between discharge pipe and suction pipe)	Controls capacity and restricts the high pressure (Frequency control backup)
Repeater	Repeater output	Prohibit(0)/Permit(1) the Communication with centralized control system
TH1	Thermistor	Detects the discharge temperature for the high pressure protection.
TH2	Thermistor (Detects saturated evaporation temperature)	Detects saturated temperature and then, control the compressor frequency and liquid level in the accumulator
TH3	Thermistor (Detects lower liquid level in the accumulator)	Detects the liquid level in the accumulator
TH4	Thermistor (Detects upper liquid level in the accumulator)	Detects the liquid level in the accumulator
TH5	Thermistor (Detects the liquid pipe temperature)	Controls compressor frequency, controls defrosting and detects the liquid level in heating mode, detects the sub-cool at the heat exchanger exit in combination with 63 HS data, and controls LEV1.
TH6	Thermistor (Detects the ambient air temperature)	Detects the ambient temperature and then, controls the fan frequency liquid level in the accumulator, and the opening LEV pulse for oil return.
TH7(8)	Thermistor (Controls SC)	Controls LEV1 based on the temperature differences between TH 6,7 and 8.
THHS	Thermistor (Inverter radiator plate temperature)	Controls the inverter cooling fan based on the THHS temperature.
63HS	High pressure sensor	Detects the discharge pressure and then protects unit against damage by high pressure.

Operation Status Monitor Terminology (PUHY - 200/250YMF)

Mark	Official Name	Meaning
Control mode		Control mode for outdoor unit
Operation mode		Operation mode for outdoor unit
F/	"Temporary compressor frequency for calculation"	Variable for control
AK	Heat exchanger capacity	Variable which determine the size of outdoor heat exchanger
AL	Accumulator level	"Liquid level in the accumulation (0: Undercharge, 1: Adequate, 2: Overcharge)"
FAN	Fan	"Fan capacity of outdoor unit (not proportional to rotational frequency)"
SCO	Sub-cool at heat exchanger	Variable for control
SCC	Sub-cool at SC coil exit	Variable for control
SHB	"SC coil bypass exit " Supper heat	Variable for control
Qj(C)	Total capacity code (cool)	Cooling indoor unit capacity
Qj(H)	Total capacity code (heat)	Heating indoor unit capacity
SLEV	Oil return LEV opening	Adjusts the amount of liquid refrigerant and oil returned from the accumulator
LEV1	SC coil LEV opening	Adjusts refrigerant in the bypass pipe from liquid pipe in the outdoor unit in cooling mode.
21S4	4-way valve	Switches the cooling/heating cycle
SV1	Solenoid valve output (Bypass between discharge pipe and suction pipe)	"Returns oil from the oil separator " Restricts the rise in the discharge pressure
SV4	Solenoid valve output (Bypass between discharge pipe and suction pipe)	Controls capacity and restricts the high pressure (Frequency control backup)
Repeater	Repeater output	Prohibit(0)/Permit(1) the Communication with centralized control system
TH1	Thermistor	Detects the discharge temperature for the high pressure protection.
TH2	Thermistor (Detects saturated evaporation temperature)	Detects saturated temperature and then, control the compressor frequency and liquid level in the accumulator
TH3	Thermistor (Detects lower liquid level in the accumulator)	Detects the liquid level in the accumulator
TH4	Thermistor (Detects upper liquid level in the accumulator)	Detects the liquid level in the accumulator
TH5	Thermistor (Detects the liquid pipe temperature)	Controls compressor frequency, controls defrosting and detects the liquid level in heating mode, detects the sub-cool at the heat exchanger exit in combination with 63 HS data, and controls LEV1.
TH6	Thermistor (Detects the ambient air temperature)	Detects the ambient temperature and then, controls the fan frequency liquid level in the accumulator, and the opening LEV pulse for oil return.
TH7(8)	Thermistor (Controls SC)	Controls LEV1 based on the temperature differences between TH 6,7 and 8.
THHS	Thermistor (Inverter radiator plate temperature)	Controls the inverter cooling fan based on the THHS temperature.
63HS	High pressure sensor	Detects the discharge pressure and then protects unit against damage by high pressure.

Operation Status Monitor Terminology (PU(H)Y-P200/250YMF-B,YMC)

Mark	Official Name	Meaning
Control mode		Control mode for outdoor unit
Operation mode		Operation mode for outdoor unit
F	Compressor frequency	Compressor frequency
AK	Heat exchanger capacity	Variable which determine the size of outdoor heat exchanger
AL	Accumulator level	Liquid level in the accumulation (0: A little, 1: Medium, 2: Much(overcharge))
FAN	Fan	Fan capacity of outdoor unit (not proportional to rotational frequency)
SCO	Sub-cool at heat exchanger Tc-TH5	Variable for control
SCC	Sub-cool at SC coil exit Tc-TH7	Variable for control
SHB	SC coil bypass exit supper he at TH8-TH2	Variable for control
Qj(C)	Total capacity code (Cool)	Cooling indoor unit capacity
Qj(H)	Total capacity code (Heat)	Heating indoor unit capacity
SLEV	Oil return LEV opening	Adjusts the amount of liquid refrigerant and oil returned from the accumulator
LEV1	SC coil LEV opening	Adjusts refrigerant in the bypass pipe from liquid pipe in the out oor unit in cooling mode
21S4	4 way valve	Switches the cooling/heating cycle (0:Cooling, 1:Heating)
SV1	Solenoid valve output (Bypass between discharge pip e and suction pipe)	Returns oil from the oil separator
SV2	Solenoid valve output (Bypass between discharge pip e and suction pipe)	Controls capacity and restricts the high pressure (Frequency contr ol backup)
Repeater	Repeater output	Prohibit(0)/Permit(1) the Communication with centralized control sy stem
TH1	Thermistor (Detects discharge temperatur e)	Detects the discharge temperature for the high pressure protection
TH2	Thermistor (Detects saturated evaporation temperature)	Detects saturated temperature and then, control the compressor fr equency and liquid level in the accumulator
TH3	Thermistor (Detects lower liquid level in t he accumulator)	Detects the liquid level in the accumulator
TH4	Thermistor (Detects upper liquid level in t he accumulator)	Detects the liquid level in the accumulator
TH5	Thermistor (Detects the liquid pipe temper ature)	Controls compressor frequency, controls defrosting and detects the liquid level in heating mode, detects the sub-cool at the heat exc hanger exit in combination with 63 HS data, and controls LEV1
TH6	Thermistor (Detects the ambient air tempe rature)	Detects the ambient temperature and then, controls the fan freque ncy liquid level in the accumulator, and the opening LEV pulse for oil return
TH7(8)	Thermistor(Controls SC)	Controls LEV1 based on the temperature differences between TH 6,7 and 8
TH9	Thermistor (Composition sensing)	Senses the refrigerant composition based on TH2, TH9 and 63LS
TH10	Thermistor (Lower compressor shell)	Detects the oil temperature
THHS	Thermistor (Inverter radiator plate tempera ture)	Controls the inverter cooling fan based on the THHS temperature
63HS	High pressure sensor	Detects the discharge pressure and then protects unit against da mage by high pressure
63LS	Low pressure sensor	Detects the suction pressure and then, senses the refrigerant com position
A-OC	Refrigerant composition(R32)	Real percentage of R32
A-OC*	Refrigerant composition(R32)	Calculated percentage of R32
Tc	Average of saturation gas tem perature of high pressure and saturation liquid temperature of high pressure	For control of compressor frequency and fan speed
Te	Saturation temperature of low	Same as TH2

	pressure	
--	----------	--

Operation Status Monitor Terminology (PU(H)Y-200/250YMF-B,YMC)

Mark	Official Name	Meaning
Control mode		Control mode for outdoor unit
Operation mode		Operation mode for outdoor unit
F	Compressor frequency	Compressor frequency
AK	Heat exchanger capacity	Variable which determine the size of outdoor heat exchanger
AL	Accumulator level	Liquid level in the accumulation (0: A little, 1: Medium, 2: Much(overcharge))
FAN	Fan	Fan capacity of outdoor unit (not proportional to rotational frequency)
SCO	Sub-cool at heat exchanger Tc-TH5	Variable for control
SCC	Sub-cool at SC coil exit Tc-TH7	Variable for control
SHB	SC coil bypass exit supper heat TH8-TH2	Variable for control
Qj(C)	Total capacity code (Cool)	Cooling indoor unit capacity
Qj(H)	Total capacity code (Heat)	Heating indoor unit capacity
SLEV	Oil return LEV opening	Adjusts the amount of liquid refrigerant and oil returned from the accumulator
LEV1	SC coil LEV opening	Adjusts refrigerant in the bypass pipe from liquid pipe in the outdoor unit in cooling mode
21S4	4 way valve	Switches the cooling/heating cycle (0:Cooling, 1:Heating)
SV1	Solenoid valve output (Bypass between discharge pipe and suction pipe)	Returns oil from the oil separator
SV2	Solenoid valve output (Bypass between discharge pipe and suction pipe)	Controls capacity and restricts the high pressure (Frequency control backup)
Repeater	Repeater output	Prohibit(0)/Permit(1) the Communication with centralized control system
TH1	Thermistor (Detects discharge temperature)	Detects the discharge temperature for the high pressure protection
TH2	Thermistor (Detects saturated evaporation temperature)	Detects saturated temperature and then, control the compressor frequency and liquid level in the accumulator
TH3	Thermistor (Detects lower liquid level in the accumulator)	Detects the liquid level in the accumulator
TH4	Thermistor (Detects upper liquid level in the accumulator)	Detects the liquid level in the accumulator
TH5	Thermistor (Detects the liquid pipe temperature)	Controls compressor frequency, controls defrosting and detects the liquid level in heating mode, detects the sub-cool at the heat exchanger exit in combination with 63 HS data, and controls LEV1
TH6	Thermistor (Detects the ambient air temperature)	Detects the ambient temperature and then, controls the fan frequency liquid level in the accumulator, and the opening LEV pulse for oil return
TH7(8)	Thermistor(Controls SC)	Controls LEV1 based on the temperature differences between TH 6,7 and 8
THHS	Thermistor (Inverter radiator plate temperature)	Controls the inverter cooling fan based on the THHS temperature
63HS	High pressure sensor	Detects the discharge pressure and then protects unit against damage by high pressure

Operation Status Monitor Terminology (PU(H)Y-200/250TM-(C))

Mark	Official Name	Meaning
Control mode		Control mode for outdoor unit
Operation mode		Operation mode for outdoor unit
F	Compressor frequency	Compressor frequency
AK	Heat exchanger capacity	Variable which determine the size of outdoor heat exchanger
AL	Accumulator level	Liquid level in the accumulation (0: A little, 1: Medium, 2: Much(overcharge))
FAN	Fan	Fan capacity of outdoor unit (not proportional to rotational frequency)
SCO	Sub-cool at heat exchanger Tc-TH5	Variable for control
SCC	Sub-cool at SC coil exit Tc-TH7	Variable for control
SHB	SC coil bypass exit supper heat TH8-TH2	Variable for control
Qj(C)	Total capacity code (Cool)	Cooling indoor unit capacity
Qj(H)	Total capacity code (Heat)	Heating indoor unit capacity
SLEV	Oil return LEV opening	Adjusts the amount of liquid refrigerant and oil returned from the accumulator
LEV1	SC coil LEV opening	Adjusts refrigerant in the bypass pipe from liquid pipe in the outdoor unit in cooling mode
21S4	4 way valve	Switches the cooling/heating cycle (0:Cooling, 1:Heating)
SV1	Solenoid valve output (Bypass between discharge pipe and suction pipe)	Returns oil from the oil separator
SV2	Solenoid valve output (Bypass between discharge pipe and suction pipe)	Controls capacity and restricts the high pressure (Frequency control backup)
Repeater	Repeater output	Prohibit(0)/Permit(1) the Communication with centralized control system
TH1	Thermistor (Detects discharge temperature)	Detects the discharge temperature for the high pressure protection
TH2	Thermistor (Detects saturated evaporation temperature)	Detects saturated temperature and then, control the compressor frequency and liquid level in the accumulator
TH3	Thermistor (Detects lower liquid level in the accumulator)	Detects the liquid level in the accumulator
TH4	Thermistor (Detects upper liquid level in the accumulator)	Detects the liquid level in the accumulator
TH5	Thermistor (Detects the liquid pipe temperature)	Controls compressor frequency, controls defrosting and detects the liquid level in heating mode, detects the sub-cool at the heat exchanger exit in combination with 63 HS data, and controls LEV1
TH6	Thermistor (Detects the ambient air temperature)	Detects the ambient temperature and then, controls the fan frequency liquid level in the accumulator, and the opening LEV pulse for oil return
TH7(8)	Thermistor(Controls SC)	Controls LEV1 based on the temperature differences between TH 6,7 and 8
THHS	Thermistor (Inverter radiator plate temperature)	Controls the inverter cooling fan based on the THHS temperature
63HS	High pressure sensor	Detects the discharge pressure and then protects unit against damage by high pressure

Operation Status Monitor Terminology (PU(H)Y-400/500YBM)

Mark	Official Name	Meaning
Control mode		Control mode for outdoor unit
Operation mode		Operation mode for outdoor unit
F	Temporary compressor frequency for calculation	Variable for control
F1	Temporary compressor frequency for NO.1 COMP for calculation	Variable for control
F2	Temporary compressor frequency for NO.2 COMP for calculation	Variable for control
AK	Heat exchanger capacity	Variable which determine the size of outdoor heat exchanger
AL	Accumulator level	Liquid level in the accumulation (0: A little, 1: Medium, 2: Much(overcharge))
FAN	Fan	Fan capacity of outdoor unit (not proportional to rotational frequency)
SCO	Sub-cool at heat exchanger Tc-TH5	Variable for control
SCC	Sub-cool at SC coil exit Tc-TH7	Variable for control
SHB	SC coil bypass exit supper heat TH8-TH2	Variable for control
Qj(C)	Total capacity code (Cool)	Cooling indoor unit capacity
Qj(H)	Total capacity code (Heat)	Heating indoor unit capacity
SLEV	Oil return LEV opening	Adjusts the amount of liquid refrigerant and oil returned from the accumulator
LEV1	SC coil LEV opening	Adjusts refrigerant in the bypass pipe from liquid pipe in the outdoor unit in cooling mode
21S4a	4 way valve Solenoid valve output (Bypass between discharge pipe and suction pipe)	Switches the cooling/heating cycle (0:Cooling, 1:Heating) Returns oil from the oil separator
SV22	Solenoid valve output (Capacity control full load)	Switches the capacity control valve Inside the compressor
SV32	Solenoid valve output (Capacity control unload)	Switches the capacity control valve Inside the compressor
SV4	Solenoid valve output (Bypass between discharge pipe and suction pipe)	Controls capacity and restricts the high pressure (Frequency control backup)
21S4b	Solenoid valve output (Capacity control of heat exchanger)	Capacity control of heat exchanger
SV5B	Solenoid valve output (Capacity control of heat exchanger)	Capacity control of heat exchanger
SV6	Solenoid valve output	Hot gas bypass
52F	Contactora	ON/OFF switch of NO.2 fan
Repeater	Repeater output	Prohibit(0)/Permit(1) the Communication with centralized control system
TH11(TH12)	Thermistor (Detects discharge temperature)	Detects the discharge temperature for the high pressure protection
TH2	Thermistor (Detects saturated evaporation temperature)	Detects saturated temperature and then, control the compressor frequency and liquid level in the accumulator
TH3	Thermistor (Detects lower liquid level in the accumulator)	Detects the liquid level in the accumulator
TH4	Thermistor (Detects upper liquid level in the accumulator)	Detects the liquid level in the accumulator
TH5	Thermistor (Detects the liquid pipe temperature)	Controls compressor frequency, controls defrosting and detects the liquid level in heating mode, detects the sub-cool at the heat exchanger exit in combination with 63 HS data, and controls LEV1
TH6	Thermistor (Detects the ambient air temperature)	Detects the ambient temperature and then, controls the fan frequency liquid level in the accumulator, and the opening LEV pulse for oil return
TH7(8,9)	Thermistor(Controls SC)	Controls LEV1 based on the temperature differences between TH 7,8 and 9
THHS	Thermistor	Controls the inverter cooling fan based on the THHS temperature

	(Inverter radiator plate temperature)	
63HS	High pressure sensor	Detects the discharge pressure and then protects unit against damage by high pressure

Operation Status Monitor Terminology (PU(H)Y-315YMC)

Mark	Official Name	Meaning
Control mode		Control mode for outdoor unit
Operation mode		Operation mode for outdoor unit
F	Compressor frequency	Compressor frequency
AK	Heat exchanger capacity	Variable which determine the size of outdoor heat exchanger
AL	Accumulator level	Liquid level in the accumulation (0: A little, 1: Medium, 2: Much(overcharge))
FAN	Fan	Fan capacity of outdoor unit (not proportional to rotational frequency)
SCO	Sub-cool at heat exchanger Tc-TH5	Variable for control
SCC	Sub-cool at SC coil exit Tc-TH7	Variable for control
SHB	SC coil bypass exit supper heat TH8-TH2	Variable for control
Qj(C)	Total capacity code (Cool)	Cooling indoor unit capacity
Qj(H)	Total capacity code (Heat)	Heating indoor unit capacity
SLEV	Oil return LEV opening	Adjusts the amount of liquid refrigerant and oil returned from the accumulator
LEV1	SC coil LEV opening	Adjusts refrigerant in the bypass pipe from liquid pipe in the outdoor unit in cooling mode
21S4	4 way valve	Switches the cooling/heating cycle (0:Cooling, 1:Heating)
SV1	Solenoid valve output (Bypass between discharge pipe and suction pipe)	Returns oil from the oil separator
SV2	Solenoid valve output (Bypass between discharge pipe and suction pipe)	Controls capacity and restricts the high pressure (Frequency control backup)
Repeater	Repeater output	Prohibit(0)/Permit(1) the Communication with centralized control system
TH1	Thermistor (Detects discharge temperature)	Detects the discharge temperature for the high pressure protection
TH2	Thermistor (Detects saturated evaporation temperature)	Detects saturated temperature and then, control the compressor frequency and liquid level in the accumulator
TH3	Thermistor (Detects lower liquid level in the accumulator)	Detects the liquid level in the accumulator
TH4	Thermistor (Detects upper liquid level in the accumulator)	Detects the liquid level in the accumulator
TH5	Thermistor (Detects the liquid pipe temperature)	Controls compressor frequency, controls defrosting and detects the liquid level in heating mode, detects the sub-cool at the heat exchanger exit in combination with 63 HS data, and controls LEV1
TH6	Thermistor (Detects the ambient air temperature)	Detects the ambient temperature and then, controls the fan frequency liquid level in the accumulator, and the opening LEV pulse for oil return
TH7(8)	Thermistor(Controls SC)	Controls LEV1 based on the temperature differences between TH 6,7 and 8
THHS	Thermistor (Inverter radiator plate temperature)	Controls the inverter cooling fan based on the THHS temperature
63HS	High pressure sensor	Detects the discharge pressure and then protects unit against damage by high pressure

Operation Status Monitor Terminology (PUHY-400/500YMF-B,YMC)

Mark	Official Name	Meaning
Control mode		Control mode for outdoor unit
Operation mode		Operation mode for outdoor unit
Save		Signal of capacity saving from system controller. figure : % No signal : 100%
F	Temporary compressor frequency for calculation	Variable for control
F1	Temporary compressor frequency of NO.1 COMP for calculation	Variable for control
F2	Temporary compressor frequency of NO.2 COMP for calculation	Variable for control
AK	Heat exchanger capacity	Variable which determine the size of outdoor heat exchanger
AK1	Heat exchanger capacity (Variable capacity unit)	Variable which determine the size of outdoor heat exchanger
AL	Accumulator level	Liquid level in the accumulation (0: A little, 1: Medium, 2: Much(overcharge))
FAN1	Fan	Fan capacity of outdoor unit(Fan on a variable capacity unit) (not proportional to rotational frequency)
SCO	Sub-cool at heat exchanger Tc-TH5	Variable for control
SCC	Sub-cool at SC coil exit Tc-TH7	Variable for control
SHB	SC coil bypass exit super heat TH8-TH2	Variable for control
DEMAND	ON/OFF demand	Input stop signal of compressor (1:effective 0:ineffective)
SNOW	Snow sensor	Input run signal of outdoor unit fan(As compressor stopped) (1:effective 0:ineffective)
NIGHT	Night mode	Decreases frequency of outdoor unit fan (1:effective 0:ineffective)
Qj(C)	Total capacity code (cool)	Cooling indoor unit capacity
Qj(H)	Total capacity code (heat)	Heating indoor unit capacity
SLEV	Oil return LEV opening	Adjusts the amount of liquid refrigerant and oil returned from the accumulator
LEV1	SC coil LEV opening	Adjusts refrigerant in the bypass pipe from liquid pipe in the outdoor unit in cooling mode.
21S4a	4-way valve	Switches the cooling/heating cycle (0:Cooling, 1:Heating)
21S4b	4-way valve	Capacity control of heat exchanger
SV1	Solenoid valve output (Bypass between discharge pipe and suction pipe)	Returns oil from the oil separator
SV22	Solenoid valve output (Capacity control full load)	Switches the capacity control valve inside the compressor
SV32	Solenoid valve output (Capacity control unload)	Switches the capacity control valve inside the compressor
SV4	Solenoid valve output (Bypass between discharge pipe and suction pipe)	Controls capacity and restricts the high pressure (Frequency control backup)
SV5b	Solenoid valve output (Capacity control of heat exchanger)	Capacity control of heat exchanger
SV6	Solenoid valve output	Hot gas bypass
52F	Contactors	ON/OFF switch of NO.2 fan
Repeater	Repeater output	Prohibit(0)/Permit(1) the Communication with centralized control system
Power		Power source frequency
TH11(TH12)	Thermistor (Detects discharge temperature)	Detects the discharge temperature for protection of compressor.
TH2	Thermistor (Detects saturated evaporation temperature)	Detects saturated temperature and then, control the compressor frequency and liquid level in the accumulator
TH3	Thermistor (Detects lower liquid level in the accumulator)	Detects the liquid level in the accumulator
TH4	Thermistor (Detects upper liquid level in	Detects the liquid level in the accumulator

	the accumulator)	
TH5	Thermistor (Detects the liquid pipe temperature)	Controls compressor frequency, controls defrosting and detects the liquid level in heating mode, detects the sub-cool at the heat exchanger exit in combination with 63 HS data, and controls LEV1.
TH6	Thermistor (Detects the ambient air temperature)	Detects the ambient temperature and then, controls the fan frequency, liquid level in the accumulator, and the opening LEV pulse for oil return.
TH7(8,9a)	Thermistor (Controls SC)	Controls LEV1 based on the temperature differences between TH 7,8 and 9a.
TH10a(10b)	Thermistor (Gas pipe temperature of heat exchanger)	Detects outlet temperature of heat exchanger in heating mode.
THHS	Thermistor (Inverter radiator plate temperature)	Controls the inverter cooling fan based on the THHS temperature.
63HS	High pressure sensor	Detects the discharge pressure and then protects unit against damage by high pressure.
Tc	Average of saturation gas temperature of high pressure and saturation liquid temperature of high pressure	For control of compressor frequency and fan speed.

Operation Status Monitor Terminology (PUHY-P400/500YMF-B,YMC)

Mark	Official Name	Meaning
Control mode		Control mode for outdoor unit
Operation mode		Operation mode for outdoor unit
Save		Signal of capacity saving from system controller.
		figure : % No signal : 100%
F	Temporary compressor frequency for calculation	Variable for control
F1	Temporary compressor frequency of NO.1 COMP for calculation	Variable for control
F2	Temporary compressor frequency of NO.2 COMP for calculation	Variable for control
AK	Heat exchanger capacity	Variable which determine the size of outdoor heat exchanger
AK1	Heat exchanger capacity (Variable capacity unit)	Variable which determine the size of outdoor heat exchanger
AL	Accumulator level	Liquid level in the accumulation (0: A little, 1: Medium, 2: Much(overcharge))
FAN1	Fan	Fan capacity of outdoor unit(Fan on a variable capacity unit) (not proportional to rotational frequency)
SCO	Sub-cool at heat exchanger Tc-TH5	Variable for control
SCC	Sub-cool at SC coil exit Tc-TH7	Variable for control
SHB	SC coil bypass exit super heat TH8-TH2	Variable for control
DEMAND	ON/OFF demand	Input stop signal of compressor
SNOW	Snow sensor	Input run signal of outdoor unit fan(As compressor stopped) (1:effective 0:ineffective)
NIGHT	Night mode	Decreases frequency of outdoor unit fan (1:effective 0:ineffective)
Qj(C)	Total capacity code (cool)	Cooling indoor unit capacity
Qj(H)	Total capacity code (heat)	Heating indoor unit capacity
SLEV	Oil return LEV opening	Adjusts the amount of liquid refrigerant and oil returned from the accumulator
LEV1	SC coil LEV opening	Adjusts refrigerant in the bypass pipe from liquid pipe in the outdoor unit in cooling mode.
21S4a	4-way valve	Switches the cooling/heating cycle (0:Cooling, 1:Heating)
21S4b	4-way valve	Capacity control of heat exchanger
SV1	Solenoid valve output (Bypass between discharge pipe and suction pipe)	Returns oil from the oil separator
SV22	Solenoid valve output (Capacity control full load)	Switches the capacity control valve inside the compressor
SV32	Solenoid valve output (Capacity control unload)	Switches the capacity control valve inside the compressor
SV4	Solenoid valve output (Bypass between discharge pipe and suction pipe)	Controls capacity and restricts the high pressure(Frequency control backup)
SV5b	Solenoid valve output (Capacity control of heat exchanger)	Capacity control of heat exchanger
SV6	Solenoid valve output	Hot gas bypass
52F	Contactors	ON/OFF switch of NO.2 fan
Repeater	Repeater output	Prohibit(0)/Permit(1) the Communication with centralized control system
Power		Power source frequency
TH11(TH12)	Thermistor (Detects discharge temperature)	Detects the discharge temperature for protection of compressor.
TH2	Thermistor (Detects saturated evaporation temperature)	Detects saturated temperature and then, control the compressor frequency and liquid level in the accumulator
TH3	Thermistor (Detects lower liquid level in the accumulator)	Detects the liquid level in the accumulator
TH4	Thermistor (Detects upper liquid level in the accumulator)	Detects the liquid level in the accumulator

	he accumulator)	
TH5	Thermistor (Detects the liquid pipe temperature)	Controls compressor frequency, controls defrosting and detects the liquid level in heating mode, detects the sub-cool at the heat exchanger exit in combination with 63 HS data, and controls LEV1.
TH6	Thermistor (Detects the ambient air temperature)	Detects the ambient temperature and then, controls the fan frequency, liquid level in the accumulator, and the opening LEV pulse for oil return.
TH7(8,9a)	Thermistor (Controls SC)	Controls LEV1 based on the temperature differences between TH 7,8 and 9a.
TH9b	Thermistor (Composition sensing)	Senses the refrigerant composition based on TH2,TH9b and 63LS.
TH10a(10b)	Thermistor (Gas pipe temperature of heat exchanger)	Detects outlet temperature of heat exchanger in heating mode.
TH10c	Thermistor (Lower compressor shell)	Detects the oil temperature
THHS	Thermistor (Inverter radiator plate temperature)	Controls the inverter cooling fan based on the THHS temperature.
63HS	High pressure sensor	Detects the discharge pressure and then protects unit against damage by high pressure.
63LS	Low pressure sensor	Detects the suction pressure and then, senses the refrigerant composition.
A-OC	Refrigerant composition(R32)	
A-OC*	Refrigerant composition(R32)	Calculated percentage of R32
Tc	Average of saturation gas Temperature of high pressure and saturation liquid temperature of high pressure	For control of compressor frequency and fan speed.
Te	Saturation temperature of low pressure	same as TH2.

Operation Status Monitor Terminology (PU(H)Y-P200/250YMF-C)

Mark	Official Name	Meaning
Control mode		Control mode for outdoor unit
Operation mode	Operation mode for outdoor unit	
Save		Signal of capacity saving from system controller. figure : %
F	Compressor frequency	Compressor frequency
AK	Heat exchanger capacity	Variable which determine the size of outdoor heat exchanger
AL	Accumulator level	Liquid level in the accumulation (0: A little, 1: Medium, 2: Much(overcharge))
FAN	Fan	Fan capacity of outdoor unit (not proportional to rotational frequency)
SCO	Sub-cool at heat exchanger Tc-TH5	Variable for control
SCC	Sub-cool at SC coil exit Tc-TH7	Variable for control
SHB	SC coil bypass exit supper heat Variable for control TH8-TH2	
DEMAND	ON/OFF demand	Input stop signal of compressor (1:effective 0:ineffective)
NIGHT	Night mode	Decreases frequency of outdoor unit fan (1:effective 0:ineffective)
Qj(C)	Total capacity code (cool)	Cooling indoor unit capacity
Qj(H)	Total capacity code (heat)	Heating indoor unit capacity
SLEV	Oil return LEV opening	Adjusts the amount of liquid refrigerant and oil returned from the accumulator
LEV1	SC coil LEV opening	Adjusts refrigerant in the bypass pipe from liquid pipe in the outdoor unit in cooling mode.
21S4	4-way valve	Switches the cooling/heating cycle (0:Cooling, 1:Heating)
SV1	Solenoid valve output (Bypass between discharge pipe and suction pipe)	Returns oil from the oil separator
SV2	Solenoid valve output (Bypass between discharge pipe and suction pipe)	Controls capacity and restricts the high pressure (Frequency control backup)
SV3	Solenoid valve output (Capacity control of heat exchanger)	Capacity control of heat exchanger
SV4	Solenoid valve output (Capacity control of heat exchanger)	Capacity control of heat exchanger
Repeater	Repeater output	Prohibit(0)/Permit(1) the Communication with centralized control system
TH1	Thermistor (Detects discharge temperature)	Detects the discharge temperature for the high pressure protection.
TH2	Thermistor (Detects saturated evaporation temperature)	Detects saturated temperature and then, control the compressor frequency and liquid level in the accumulator
TH5	Thermistor (Detects the liquid pipe temperature)	Controls compressor frequency, controls defrosting and detects the liquid level in heating mode, detects the sub-cool at the heat exchanger exit in combination with 63 HS data, and controls LEV1.
TH6	Thermistor (Detects the ambient air temperature)	Detects the ambient temperature and then, controls the fan frequency liquid level in the accumulator, and the opening LEV pulse for oil return.
TH7(8)	Thermistor	Controls LEV1 based on the temperature differences between TH 6,7 and 8.
	(Controls SC)	
TH9	Thermistor (Composition sensing)	Senses the refrigerant composition based on TH2, TH9 and 63LS.
TH10	Thermistor (Lower compressor shell)	Detects the oil temperature
THHS	Thermistor (Inverter radiator plate temperature)	Controls the inverter cooling fan based on the THHS temperature.
63HS	High pressure sensor	Detects the discharge pressure and then protects unit against damage by high pressure.
63LS	Low pressure sensor	Detects the suction pressure and then, senses the refrigerant com

		position.
A-OC	Refrigerant composition(R32)	Real percentage of R32
A-OC*	Refrigerant composition(R32)	Calculated percentage of R32
Tc	Average of saturation gas temperature of high pressure and saturation liquid temperature of high pressure	For control of compressor frequency and fan speed
Te	Saturation temperature of low pressure	Same as TH2

Operation Status Monitor Terminology (PUHY-P400/500YMF-C)

Mark	Official Name	Meaning
Control mode		Control mode for outdoor unit
Operation mode		Operation mode for outdoor unit
Save		Signal of capacity saving from system controller. figure : % No signal : 100%
F	Temporary compressor frequency for calculation	Variable for control
F1	Temporary compressor frequency of NO.1 COMP for calculation	Variable for control
F2	Temporary compressor frequency of NO.2 COMP for calculation	Variable for control
AK1	Heat exchanger capacity (Variable capacity unit)	Variable which determine the size of outdoor heat exchanger
AL	Accumulator level	Liquid level in the accumulation (0: A little, 1: Medium, 2: Much(overcharge))
FAN1	Fan	Fan capacity of outdoor unit(Fan on a variable capacity unit) (not proportional to rotational frequency)
SCO	Sub-cool at heat exchanger Tc-TH5	Variable for control
SCC	Sub-cool at SC coil exit Tc-TH7	Variable for control
SHB	SC coil bypass exit super heat TH8-TH2	Variable for control
DEMAND	ON/OFF demand	Input stop signal of compressor
SNOW	Snow sensor	Input run signal of outdoor unit fan(As compressor stopped) (1:effective 0:ineffective)
NIGHT	Night mode	Decreases frequency of outdoor unit fan (1:effective 0:ineffective)
Qj(C)	Total capacity code (cool)	Cooling indoor unit capacity
Qj(H)	Total capacity code (heat)	Heating indoor unit capacity
SLEV	Oil return LEV opening	Adjusts the amount of liquid refrigerant and oil returned from the accumulator
LEV1	SC coil LEV opening	Adjusts refrigerant in the bypass pipe from liquid pipe in the outdoor unit in cooling mode.
21S4a	4-way valve	Switches the cooling/heating cycle (0:Cooling, 1:Heating)
21S4b	4-way valve	Capacity control of heat exchanger
SV1	Solenoid valve output	Returns oil from the oil separator (Bypass between discharge pipe and suction pipe)
SV22	Solenoid valve output (Capacity control full load)	Switches the capacity control valve inside the compressor
SV32	Solenoid valve output (Capacity control unload)	Switches the capacity control valve inside the compressor
SV4	Solenoid valve output (Bypass between discharge pipe and suction pipe)	Controls capacity and restricts the high pressure(Frequency control backup)
SV5b	Solenoid valve output (Capacity control of heat exchanger)	Capacity control of heat exchanger
SV6	Solenoid valve output (Capacity control of heat exchanger)	Capacity control of heat exchanger
SV7	Solenoid valve output (Capacity control of heat exchanger)	Capacity control of heat exchanger
SV8	Solenoid valve output (Capacity control of heat exchanger)	Capacity control of heat exchanger
52F	Contactora	ON/OFF switch of NO.2 fan
Repeater	Repeater output	Prohibit(0)/Permit(1) the Communication with centralized control system
Power		Power source frequency
TH11(TH12)	Thermistor (Detects discharge temperature)	Detects the discharge temperature for protection of compressor.
TH2	Thermistor (Detects saturated evaporator)	Detects saturated temperature and then, control the compressor frequency and liquid level in the accumulator

	n temperature)	
TH3	Thermistor (Detects lower liquid level in the accumulator)	Detects the liquid level in the accumulator
TH4	Thermistor (Detects upper liquid level in the accumulator)	Detects the liquid level in the accumulator
TH5	Thermistor (Detects the liquid pipe temperature)	Controls compressor frequency, controls defrosting and detects the liquid level in heating mode, detects the sub-cool at the heat exchanger exit in combination with 63 HS data, and controls LEV1.
TH6	Thermistor (Detects the ambient air temperature)	Detects the ambient temperature and then, controls the fan frequency, liquid level in the accumulator, and the opening LEV pulse for oil return.
TH7(8,9a)	Thermistor(Controls SC)	Controls LEV1 based on the temperature differences between TH 7,8 and 9a.
TH9b	Thermistor(Composition sensing)	Senses the refrigerant composition based on TH2,TH9b and 63LS.
TH10a(10b)	Thermistor (Gas pipe temperature of heat exchanger)	Detects outlet temperature of heat exchanger in heating mode.
TH10c	Thermistor (Lower compressor shell)	Detects the oil temperature
THHS	Thermistor (Inverter radiator plate temperature)	Controls the inverter cooling fan based on the THHS temperature.
63HS	High pressure sensor	Detects the discharge pressure and then protects unit against damage by high pressure.
63LS	Low pressure sensor	Detects the suction pressure and then, senses the refrigerant composition.
A-OC	Refrigerant composition(R32)	Real percentage of R32
A-OC*	Refrigerant composition(R32)	Calculated percentage of R32
Tc	Average of saturation gas temperature of high pressure and saturation liquid temperature of high pressure	For control of compressor frequency and fan speed.
Te	Saturation temperature of low pressure	same as TH2.

Operation Status Monitor Terminology (PUHY-400/500YMF-C)

Mark	Official Name	Meaning
Control mode		Control mode for outdoor unit
Operation mode		Operation mode for outdoor unit
Save		Signal of capacity saving from system controller. figure : % No signal : 100%
F	Temporary compressor frequency for calculation	Variable for control
F1	Temporary compressor frequency of NO.1 COMP for calculation	Variable for control
F2	Temporary compressor frequency of NO.2 COMP for calculation	Variable for control
AK	Heat exchanger capacity	Variable which determine the size of outdoor heat exchanger
AK1	Heat exchanger capacity (Variable capacity unit)	Variable which determine the size of outdoor heat exchanger
AL	Accumulator level	Liquid level in the accumulation (0: A little, 1: Medium, 2: Much(overcharge))
FAN1	Fan	Fan capacity of outdoor unit(Fan on a variable capacity unit) (not proportional to rotational frequency)
SCO	Sub-cool at heat exchanger Tc-TH5	Variable for control
SCC	Sub-cool at SC coil exit Tc-TH7	Variable for control
SHB	SC coil bypass exit super heat TH8-TH2	Variable for control
DEMAND	ON/OFF demand	Input stop signal of compressor (1:effective 0:ineffective)
SNOW	Snow sensor	Input run signal of outdoor unit fan(As compressor stopped) (1:effective 0:ineffective)
NIGHT	Night mode	Decreases frequency of outdoor unit fan (1:effective 0:ineffective)
Qj(C)	Total capacity code (cool)	Cooling indoor unit capacity
Qj(H)	Total capacity code (heat)	Heating indoor unit capacity
SLEV	Oil return LEV opening	Adjusts the amount of liquid refrigerant and oil returned from the accumulator
LEV1	SC coil LEV opening	Adjusts refrigerant in the bypass pipe from liquid pipe in the outdoor unit in cooling mode.
21S4a	4-way valve	Switches the cooling/heating cycle (0:Cooling, 1:Heating)
21S4b	4-way valve	Capacity control of heat exchanger
SV1	Solenoid valve output (Bypass between discharge pipe and suction pipe)	Returns oil from the oil separator
SV22	Solenoid valve output (Capacity control full load)	Switches the capacity control valve inside the compressor
SV32	Solenoid valve output (Capacity control unload)	Switches the capacity control valve inside the compressor
SV4	Solenoid valve output (Bypass between discharge pipe and suction pipe)	Controls capacity and restricts the high pressure(Frequency control backup)
SV5b	Solenoid valve output (Capacity control of heat exchanger)	Capacity control of heat exchanger
SV6	Solenoid valve output (Capacity control of heat exchanger)	Capacity control of heat exchanger
52F	Contactors	ON/OFF switch of NO.2 fan
Repeater	Repeater output	Prohibit(0)/Permit(1) the Communication with centralized control system
Power		Power source frequency
TH11(TH12)	Thermistor (Detects discharge temperature)	Detects the discharge temperature for protection of compressor.
TH2	Thermistor (Detects saturated evaporation temperature)	Detects saturated temperature and then, control the compressor frequency and liquid level in the accumulator
TH3	Thermistor (Detects lower liquid level in	Detects the liquid level in the accumulator

	the accumulator)	
TH4	Thermistor (Detects upper liquid level in the accumulator)	Detects the liquid level in the accumulator
TH5	Thermistor (Detects the liquid pipe temperature)	Controls compressor frequency, controls defrosting and detects the liquid level in heating mode, detects the sub-cool at the heat exchanger exit in combination with 63 HS data, and controls LEV1.
TH6	Thermistor (Detects the ambient air temperature)	Detects the ambient temperature and then, controls the fan frequency, liquid level in the accumulator, and the opening LEV pulse for oil return.
TH7(8,9a)	Thermistor (Controls SC)	Controls LEV1 based on the temperature differences between TH 7,8 and 9a.
TH10a(10b)	Thermistor (Gas pipe temperature of heat exchanger)	Detects outlet temperature of heat exchanger in heating mode.
THHS	Thermistor (Inverter radiator plate temperature)	Controls the inverter cooling fan based on the THHS temperature.
63HS	High pressure sensor	Detects the discharge pressure and then protects unit against damage by high pressure.
Tc	Average of saturation gas temperature of high pressure and saturation liquid temperature of high pressure	For control of compressor frequency and fan speed.

Operation Status Monitor Terminology (PUD-P200/250YMF-C)

Mark	Official Name	Meaning
Ctrl Mode		Control mode for outdoor unit
Ctrl Mode		Control mode for outdoor unit
Ope Mode		Operation mode for outdoor unit
Save		Signal of capacity saving from system controller figure : % No signal : 100%
Power	Power source frequency	Power source frequency (Hz)
F	Temporary compressor frequency for calculation	Variable for control
AK	Heat exchanger capacity	Variable which determines the size of outdoor heat exchanger
FAN	Fan	Fan capacity of outdoor unit (not proportional to rotational frequency)
DEMAND	ON/OFF demand	Input stop signal of compressor (ON:effective, OFF:ineffective)
SNOW	Snow sensor	Input run signal of outdoor unit fan (As compressor stopped) (ON:effective, OFF:ineffective)
NIGHT	Night mode	Decreases frequency of outdoor unit fan (ON:effective, OFF:ineffective)
QjC	Total capacity code (cool)	Cooling indoor unit capacity
SLEV	Oil return LEV opening	Adjusts the amount of liquid refrigerant and oil returned from the accumulator
LEV1	SC coil LEV opening	Adjusts refrigerant in the bypass pipe from liquid pipe in the outdoor unit in cooling mode
SV1	Solenoid valve output (Bypass between discharge pipe and suction pipe)	The discharge pressure control
SV2	Solenoid valve output (Bypass between discharge pipe and suction pipe)	The discharge pressure control
SV3	Solenoid valve output	Capacity control of heat exchanger
TH1	Thermistor (Detects discharge temperature)	Detects discharge temperature for protection of compressor.
TH2	Thermistor	
TH5	Thermistor (Detects the liquid pipe temperature)	Controls defrosting (start/ end) in heating mode
TH6	Thermistor (Detects the ambient air temperature)	Detects the ambient temperature and then, controls the fan frequency and liquid level in the accumulator.
TH7(8)	Thermistor (Controls SC)	Controls LEV1 based on the temperature differences between TH 6,7 and 8
TH9	Thermistor	Detects the high pressure liquid temperature
TH10	Thermistor	Detects lower compressor shell and then protects compressor.
THHS	Thermistor (Comp inverter radiator plate temperature)	Controls the Comp inverter cooling fan based on the THHS temperature.
63HS	High pressure sensor	Detects the discharge pressure and then protects unit against damage by high pressure.
63LS	Low pressure sensor	Detects the suction pressure and then, senses the refrigerant composition
Tc	Average of saturation gas temperature of high pressure and saturation liquid temperature of high pressure	For control of compressor frequency and fan speed
Te	Saturation temperature of low pressure	For control of compressor frequency and fan speed
SCO	Sub-cool at heat exchanger	Variable for control
Tc-TH5		
SCC	Sub-cool at SC coil exit Tc-TH7	Variable for control
SHB	SC coil bypass exit super heat TH8-Te	Variable for control
A_oc	Refrigerant composition(R32)	Real percentage of R32
A_oc*	Refrigerant composition(R32)	Calculated percentage of R32

--	--	--

Operation Status Monitor Terminology (PU(H)Y-P200/250/315Y(R)EM-A)

Mark	Official Name	Meaning
Ctrl Mode		Control mode for outdoor unit
Ope Mode		Operation mode for outdoor unit
Save		Signal of capacity saving from system controller. figure : % No signal : 100%
F	Compressor frequency	Compressor frequency
AK	Heat exchanger capacity	Variable which determines the size of outdoor heat exchanger
AL	Accumulator level	Liquid level in the accumulation (0: A little, 1: Medium, 2: Much(overcharge))
FAN	Fan	Fan capacity of outdoor unit (not proportional to rotational frequency)
SCO	Sub-cool at heat exchanger Tc-TH5	Variable for control
SCC	Sub-cool at SC coil exit Tc-TH7	Variable for control
SHB	SC coil bypass exit super heat TH8-TH2	Variable for control
DEMAND	ON/OFF demand	Input stop signal of compressor (ON:effective, OFF:ineffective)
DEMAND2		Signal of capacity saving (ON:effective, OFF:ineffective)
SNOW	Snow sensor	Input run signal of outdoor unit fan (As compressor stopped) (ON:effective, OFF:ineffective)
NIGHT	Night mode	Decreases frequency of outdoor unit fan (ON:effective, OFF:ineffective)
Qj(C)	Total capacity code (cool)	Cooling indoor unit capacity
Qj(H)	Total capacity code (heat)	Heating indoor unit capacity damage by high pressure. "closing": at the time of usual. "open": at the time of actuation.
SLEV	Oil return LEV opening	Adjusts the amount of liquid refrigerant and oil returned from the accumulator
LEV1	SC coil LEV opening	Adjusts refrigerant in the bypass pipe from liquid pipe in the outdoor unit in cooling mode.
21S4	4-way valve	Switches the cooling/heating cycle (0:Cooling, 1:Heating)
SV1	Solenoid valve output (Bypass between discharge pipe and suction pipe)	Returns oil from the oil separator
SV2	Solenoid valve output (Bypass between discharge pipe and suction pipe)	Discharge-suction bypass
SV3	Solenoid valve output (Capacity control of heat exchanger)	Capacity control of heat exchanger
SV4	Solenoid valve output (Capacity control of heat exchanger)	Capacity control of heat exchanger
Repeater	Repeater output	Prohibit(0)/Permit(1) the communication with centralized control system
TH1	Thermistor (Detects discharge temperature)	Detects the discharge temperature for the high pressure protection.
TH2	Thermistor (Detects saturated evaporation temperature)	Detects saturated temperature and then, controls the compressor frequency and liquid level in the accumulator
TH5	Thermistor (Detects the liquid pipe temperature)	Controls compressor frequency and defrosting and detects the liquid level in heating mode and the sub-cool at the heat exchanger exit in combination with 63 HS data, and controls LEV1.
TH6	Thermistor (Detects the ambient air temperature)	Detects the ambient temperature and then, controls the fan frequency and liquid level in the accumulator.
TH7(8)	Thermistor (Controls SC)	Controls LEV1 based on the temperature differences between TH 6,7 and 8.
THHS	Thermistor (Inverter radiator plate temperature)	Controls the inverter cooling fan based on the THHS temperature.
63HS	High pressure sensor	Detects the discharge pressure and then protects unit against damage by high pressure.

63LS	Low pressure sensor	Detects the suction pressure and then, senses the refrigerant composition.
A-OC	Refrigerant composition(R32)	Real percentage of R32
A-OC*	Refrigerant composition(R32)	Calculated percentage of R32
Tc	Average of saturation gas temperature of high pressure and saturation liquid temperature of high pressure	For control of compressor frequency and fan speed
Te	Saturation temperature of low pressure	Same as TH2
Vdc	Bus voltage	Bus voltage
Idc	DC trunk line current	DC trunk line current
Iu	Phase-U current	Phase-U current of compressor
Iw	Phase-W current	Phase-W current of compressor

Operation Status Monitor Terminology (PU(H)Y-P200/250/315YEM(*)-A)

Mark	Official Name	Meaning
Ctrl Mode		Control mode for outdoor unit
Ope Mode		Operation mode for outdoor unit
Save		Signal of capacity saving from system controller. figure : % No signal : 100%
F	Compressor frequency	Compressor frequency
AK	Heat exchanger capacity	Variable which determines the size of outdoor heat exchanger
AL	Accumulator level	Liquid level in the accumulation (0: A little, 1: Medium, 2: Much(overcharge))
FAN	Fan	Fan capacity of outdoor unit (not proportional to rotational frequency)
SCO	Sub-cool at heat exchanger Tc-TH5	Variable for control
SCC	Sub-cool at SC coil exit Tc-TH7	Variable for control
SHB	SC coil bypass exit super heat TH8-TH2	Variable for control
DEMAND	ON/OFF demand	Input stop signal of compressor (ON : effective OFF : ineffective)
DEMAND2		Signal of capacity saving (ON : effective OFF : ineffective)
SNOW	Snow sensor	Input run signal of outdoor unit fan (As compressor stopped) (ON : effective OFF : ineffective)
NIGHT	Night mode	Decreases frequency of outdoor unit fan (ON : effective OFF : ineffective)
Qj(C)	Total capacity code (cool)	Cooling indoor unit capacity
Qj(H)	Total capacity code (heat)	Heating indoor unit capacity
LEV1	SC coil LEV opening	Adjusts refrigerant in the bypass pipe from liquid pipe in the outdoor unit in cooling mode.
21S4	4-way valve	Switches the cooling/heating cycle (0:Cooling, 1:Heating)
SV1	Solenoid valve output (Bypass between discharge pipe and suction pipe)	Returns oil from the oil separator
SV3	Solenoid valve output (Capacity control of heat exchanger)	Capacity control of heat exchanger
SV4	Solenoid valve output (Capacity control of heat exchanger)	Capacity control of heat exchanger
Repeater	Repeater output	Prohibit(0)/Permit(1) the communication with centralized control system
TH1	Thermistor (Detects discharge temperature)	Detects the discharge temperature for the high pressure protection.
TH2	Thermistor (Detects saturated evaporation temperature)	Detects saturated temperature and then, controls the compressor frequency and liquid level in the accumulator
TH5	Thermistor (Detects the liquid pipe temperature)	Controls compressor frequency and defrosting and detects the liquid level in heating mode and the sub-cool at the heat exchanger exit in combination with 63 HS data, and controls LEV1.
TH6	Thermistor (Detects the ambient air temperature)	Detects the ambient temperature and then, controls the fan frequency and liquid level in the accumulator.
TH7(8)	Thermistor (Controls SC)	Controls LEV1 based on the temperature differences between TH 6,7 and 8.
THHS	Thermistor (Inverter radiator plate temperature)	Controls the inverter cooling fan based on the THHS temperature.
63HS	High pressure sensor	Detects the discharge pressure and then protects unit against damage by high pressure.
63LS	Low pressure sensor	Detects the suction pressure and then, senses the refrigerant composition.
A-OC	Refrigerant composition(R32)	Real percentage of R32
A-OC*	Refrigerant composition(R32)	Calculated percentage of R32

Tc	Average of saturation gas temperature of high pressure and saturation liquid temperature of high-pressure	For control of compressor frequency and fan speed
Te	Saturation temperature of low pressure	Same as TH2
Vdc	Bus voltage	Bus voltage
Idc	DC trunk line current	DC trunk line current
Iu	Phase-U current	Phase-U current of compressor
Iw	Phase-W current	Phase-W current of compressor

Operation Status Monitor Terminology (PU(H)Y-200/250/315YEM(*)-A)

Mark	Official Name	Meaning
Ctrl Mode		Control mode for outdoor unit
Ope Mode		Operation mode for outdoor unit
Save		Signal of capacity saving from system controller. figure : % No signal : 100%
F	Compressor frequency	Compressor frequency
AK	Heat exchanger capacity	Variable which determines the size of outdoor heat exchanger
AL	Accumulator level	Liquid level in the accumulation (0: A little, 1: Medium, 2: Much(overcharge))
FAN	Fan	Fan capacity of outdoor unit (not proportional to rotational frequency)
SCO	Sub-cool at heat exchanger Tc-TH5	Variable for control
SCC	Sub-cool at SC coil exit Tc-TH7	Variable for control
SHB	SC coil bypass exit super heat TH8-TH2	Variable for control
DEMAND	ON/OFF demand	Input stop signal of compressor (ON : effective OFF : ineffective)
DEMAND2		Signal of capacity saving (ON : effective OFF : ineffective)
SNOW	Snow sensor	Input run signal of outdoor unit fan (As compressor stopped) (ON : effective OFF : ineffective)
NIGHT	Night mode	Decreases frequency of outdoor unit fan (ON : effective OFF : ineffective)
Qj(C)	Total capacity code (cool)	Cooling indoor unit capacity
Qj(H)	Total capacity code (heat)	Heating indoor unit capacity
LEV1	SC coil LEV opening	Adjusts refrigerant in the bypass pipe from liquid pipe in the outdoor unit in cooling mode.
21S4	4-way valve	Switches the cooling/heating cycle (0:Cooling, 1:Heating)
SV1	Solenoid valve output (Bypass between discharge pipe and suction pipe)	Returns oil from the oil separator
Repeater	Repeater output	Prohibit(0)/Permit(1) the communication with centralized control system
TH1	Thermistor (Detects discharge temperature)	Detects the discharge temperature for the high pressure protection.
TH5	Thermistor (Detects the liquid pipe temperature)	Controls compressor frequency, and defrosting and detects the liquid level in heating mode and the sub-cool at the heat exchanger exit in combination with 63 HS data, and controls LEV1.
TH6	Thermistor (Detects the ambient air temperature)	Detects the ambient temperature and then, controls the fan frequency and liquid level in the accumulator.
TH7(8)	Thermistor (Controls SC)	Controls LEV1 based on the temperature differences between TH 6,7 and 8.
THHS	Thermistor (Inverter radiator plate temperature)	Controls the inverter cooling fan based on the THHS temperature.
63HS	High pressure sensor	Detects the discharge pressure and then protects unit against damage by high pressure.
63LS	Low pressure sensor	Detects the suction pressure and then, senses the refrigerant composition.
Vdc	Bus voltage	Bus voltage
Idc	DC trunk line current	DC trunk line current
Iu	Phase-U current	Phase-U current of compressor
Iw	Phase-W current	Phase-W current of compressor

Operation Status Monitor Terminology (PUHY-P700/750/800YSGM-A)

Mark	Official Name	Meaning
Ctrl Mode		Control mode for outdoor unit
Ope Mode		Operation mode for outdoor unit
Save		Signal of capacity saving from system controller. figure : % No signal : 100%
Power	Power source frequency	Power source frequency (Hz)
F	Temporary compressor frequency for calculation	Variable for control
F1	Temporary compressor frequency of No.1 Comp for calculation	Variable for control
F2	Temporary compressor frequency of No.2 Comp for calculation	Variable for control
AK	Heat exchanger capacity	Variable which determines the size of outdoor heat exchanger
FAN1	Fan	Fan capacity of compressor unit (not proportional to rotational frequency)
FAN2	Fan	Fan capacity of heat exchanger unit (not proportional to rotational frequency)
DEMAND	ON/OFF demand	Input stop signal of compressor (ON:effective, OFF:ineffective)
DEMAND2	Intermediate demand	Signal of capacity saving (ON:effective, OFF:ineffective) DEMAND=OFF, DEMAND2=OFF: 100% DEMAND=OFF, DEMAND2=ON : 75% DEMAND= ON, DEMAND2=ON : 50% DEMAND= ON, DEMAND2=OFF: 25%
SNOW	Snow sensor	Input run signal of outdoor unit fan (As compressor stopped) (ON:effective, OFF:ineffective)
NIGHT	Night mode	Decreases frequency of outdoor unit fan (ON:effective, OFF:ineffective)
Qj(C)	Total capacity code (cool)	Cooling indoor unit capacity
Qj(H)	Total capacity code (heat)	Heating indoor unit capacity
LEV1	SC coil LEV opening	Adjusts refrigerant in the bypass pipe from liquid pipe in the outdoor unit in cooling mode.
21S4a	4-way valve	Switches the cooling/heating cycle (0:Cooling, 1:Heating)
21S4b	4-way valve	Capacity control of heat exchanger (Gas side)
21S4c	4-way valve	Capacity control of heat exchanger (Gas side)
SV1	Solenoid valve output (Bypass between discharge pipe and suction pipe)	The discharge pressure control
SV3	Solenoid valve output (Bypass between discharge pipe and suction pipe)	Protects compressor when compressor stops.
SV5b	Solenoid valve output	Capacity control of heat exchanger (Liquid side).
SV5c	Solenoid valve output	Capacity control of heat exchanger (Liquid side).
Rep	Repeater output	Prohibit(0)/Permit(1) the communication with centralized control system
TH11	Thermistor (Detects discharge temperature)	Detects discharge temperature for protection of No.1 compressor.
TH12	Thermistor (Detects discharge temperature)	Detects discharge temperature for protection of No.2 compressor.
TH5	Thermistor (Detects the liquid pipe temperature)	Controls defrosting (start/ end) in heating mode.
TH6	Thermistor (Detects the ambient air temperature)	Detects the ambient temperature and then, controls the fan frequency and liquid level in the accumulator.
TH7(8)	Thermistor (Controls SC)	Controls LEV1 based on the temperature differences between TH7 and 8.
TH10	Thermistor	Detects lower compressor shell and then protects compressor.
T5b	Thermistor TH5b	Controls defrosting (start/ end) in heating mode (No.1 compressor).
THHS1	Thermistor (Comp inverter radiator plate temperature)	Controls the Comp inverter1 cooling fan based on the THHS1 temperature.

THHS2	Thermistor (Comp inverter radiator plate temperature)	Controls the Comp inverter2 cooling fan based on the THHS2 temperature.
THHS5	Thermistor (Fan inverter radiator plate temperature)	Controls the Fan inverter cooling fan based on the THHS5 temperature.
TS5	Thermistor THHS5 (Fan inverter radiator plate temperature)	Controls the Fan inverter cooling fan based on the TS5 temperature.
63HS	High pressure sensor	Detects the discharge pressure and then protects unit against damage by high pressure.
63LS	Low pressure sensor	Detects the suction pressure and then, protects unit against damage by low pressure.
Tc	Average of saturation gas temperature of high pressure and saturation liquid temperature of high pressure	For control of compressor frequency and fan speed.
Te	Saturation temperature of low pressure	For control of compressor frequency and fan speed
SCO	Sub-cool at heat exchanger Tc-TH5	Variable for control
SCC	Sub-cool at SC coil exit Tc-TH7	Variable for control
SHB	SC coil bypass exit superheat TH8-Te	Variable for control
Vdc1	Bus voltage	Bus voltage of inverter1
Idc1	DC trunk line current	DC trunk line current of inverter1
Iu1	Phase-U current	Phase-U current of inverter1
Iw1	Phase-W current	Phase-W current of inverter1
Vdc2	Bus voltage	Bus voltage of inverter2
Idc2	DC trunk line current	DC trunk line current of inverter2
Iu2	Phase-U current	Phase-U current of inverter2
Iw2	Phase-W current	Phase-W current of inverter2

Operation Status Monitor Terminology

(PUHY-P200/250/300/350YGM-A, PUHY-P400YGM-A, PUHY-P450/500/550/600/650YGM-A)

Mark	Official Name	Meaning
Ctrl Mode		Control mode for outdoor unit
Ope Mode		Operation mode for outdoor unit
Save		Signal of capacity saving from system controller. figure : % No signal : 100%
Power	Power source frequency	Power source frequency (Hz)
F	Temporary compressor frequency for calculation	Variable for control
F1	Temporary compressor frequency of No.1 Comp for calculation	Variable for control (only for P450 type or over)
F2	Temporary compressor frequency of No.2 Comp for calculation	Variable for control (only for P450 type or over)
AK	Heat exchanger capacity	Variable which determines the size of outdoor heat exchanger
FAN	Fan	Fan capacity of outdoor unit (not proportional to rotational frequency)
DEMAND	ON/OFF demand	Input stop signal of compressor (ON:effective, OFF:ineffective)
DEMAND2	Intermediate demand	Signal of capacity saving (ON:effective, OFF:ineffective) DEMAND=OFF, DEMAND2=OFF: 100% DEMAND=OFF, DEMAND2=ON : 75% DEMAND= ON, DEMAND2=ON : 50% DEMAND= ON, DEMAND2=OFF: 25%
SNOW	Snow sensor	Input run signal of outdoor unit fan (As compressor stopped) (ON:effective, OFF:ineffective)
SV5	Solenoid valve output	
NIGHT	Night mode	Decreases frequency of outdoor unit fan (ON:effective, OFF:ineffective)
Qj(C)	Total capacity code (cool)	Cooling indoor unit capacity
Qj(H)	Total capacity code (heat)	Heating indoor unit capacity
LEV1	SC coil LEV opening	Adjusts refrigerant in the bypass pipe from liquid pipe in the outdoor unit in cooling mode.
21S4a	4-way valve	Switches the cooling/heating cycle (0:Cooling, 1:Heating)
21S4b	4-way valve	Capacity control of heat exchanger (Gas side)
21S4c	4-way valve	Capacity control of heat exchanger (Gas side) (only for P400 type or over)
SV1	Solenoid valve output (Bypass between discharge pipe and suction pipe)	The discharge pressure control
SV3	Solenoid valve output (Bypass between discharge pipe and suction pipe)	Protects compressor when compressor stops. (only for P450 type or over)
SV5b	Solenoid valve output	Capacity control of heat exchanger (Liquid side).
SV5c	Solenoid valve output	Capacity control of heat exchanger (Liquid side). (only for P450 type or over)
52F	Contactora	ON/OFF switch of No.2 fan (only for P450 type or over)
Rep	Repeater output	Prohibit(0)/Permit(1) the communication with centralized control system

TH11	Thermistor (Detects discharge temperature)	Detects discharge temperature for protection of No.1 compressor.
TH12	Thermistor (Detects discharge temperature)	Detects discharge temperature for protection of No.2 compressor. (only for P450 type or over)
TH5	Thermistor (Detects the liquid pipe temperature)	Controls defrosting (start/ end) in heating mode.
TH6	Thermistor (Detects the ambient air temperature)	Detects the ambient temperature and then, controls the fan frequency and liquid level in the accumulator.
TH7(8)	Thermistor (Controls SC)	Controls LEV1 based on the temperature differences between TH 6,7 and 8.
THHS1	Thermistor (Comp inverter radiator plate temperature)	Controls the Comp inverter cooling fan based on the THHS1 temperature.
THHS5	Thermistor (Fan inverter radiator plate temperature)	Controls the Fan inverter cooling fan based on the THHS5 temperature.
63HS	High pressure sensor	Detects the discharge pressure and then protects unit against damage by high pressure.
63LS	Low pressure sensor	Detects the suction pressure and then, senses the refrigerant composition.
Tc	Average of saturation gas temperature of high pressure and saturation liquid temperature of high pressure	For control of compressor frequency and fan speed.
Te	Saturation temperature of low pressure	For control of compressor frequency and fan speed
Vdc	Bus voltage	Bus voltage
Idc	DC trunk line current	DC trunk line current
Iu	Phase-U current	Phase-U current of compressor
Iw	Phase-W current	Phase-W current of compressor

Operation Status Monitor Terminology

(PUHY-P450/500/550/600/650YMM-A , PUHY-P400/650YSM-A , PUHY-P450/500/550/600/650YCSM-A , PUHY-P600YCSS-A)

Mark	Official Name	Meaning
Primality		Indicates whether the unit is primary or secondary.
Ctrl Mode		Control mode for outdoor unit
Ope Mode		Operation mode for outdoor unit
Save		Signal of capacity saving from system controller. figure : % No signal : 100%
Power	Power source frequency	Power source frequency (Hz)
F	Temporary compressor frequency for calculation	Variable for control (Total frequency : Foc+Fos)
Foc	Temporary compressor frequency for calculation	Variable for control (Total frequency of OC unit)
Fos	Temporary compressor frequency for calculation	Variable for control (Total frequency of OS unit)
F1	Temporary compressor frequency of No.1 Comp for calculation	Variable for control
F2	Temporary compressor frequency of No.2 Comp for calculation	Variable for control
AK	Heat exchanger capacity	Variable which determines the size of outdoor heat exchanger
FAN	Fan	Fan capacity of outdoor unit (not proportional to rotational frequency)
DEMAND	ON/OFF demand	Input stop signal of compressor (ON:effective OFF:ineffective)
DEMAND2	Intermediate demand	Signal of capacity saving (ON:effective OFF:ineffective) DEMAND=OFF, DEMAND2=OFF: 100% DEMAND=OFF, DEMAND2=ON : 75% DEMAND= ON, DEMAND2=ON : 50% DEMAND= ON, DEMAND2=OFF: 25%
SNOW	Snow sensor	Input run signal of outdoor unit fan (As compressor stopped) (ON:effective OFF:ineffective)
NIGHT	Night mode	Decreases frequency of outdoor unit fan (ON:effective OFF:ineffective)
Qj(C)	Total capacity code (cool)	Cooling indoor unit capacity
Qj(H)	Total capacity code (heat)	Heating indoor unit capacity
LEV1	SC coil LEV opening	Adjusts refrigerant in the bypass pipe from liquid pipe in the outdoor unit in cooling mode.
21S4a	4-way valve	Switches the cooling/heating cycle (0:Cooling, 1:Heating)
21S4b	4-way valve	Capacity control of heat exchanger (Gas side)
21S4c	4-way valve	Capacity control of heat exchanger (Gas side) Only for PUHY-PYMM-A and PUHY-PYSM-A type
SV1	Solenoid valve output (Bypass between discharge pipe and suction pipe)	The discharge pressure control
SV3	Solenoid valve output (Bypass between discharge pipe and suction pipe)	Protects compressor when No.2 compressor stops.
SV5b	Solenoid valve output	Capacity control of heat exchanger (Liquid side).
SV5c	Solenoid valve output	Capacity control of heat exchanger (Liquid side). Only for PUHY-PYMM-A and PUHY-PYSM-A type
SV5d	Solenoid valve output	Closes when outdoor unit stops.
52F	Contactors	ON/OFF switch of No.2 fan
Rep	Repeater output	Prohibit(0)/Permit(1) the communication with centralized control system
TH11	Thermistor (Detects discharge temperature)	Detects discharge temperature for protection of No.1 compressor.
TH12	Thermistor (Detects discharge temperature)	Detects discharge temperature for protection of No.2 compressor.
TH2	Thermistor (Detects the heat exchanger exit temperature)	Detects the temperature of the inlet to accumulator
TH5	Thermistor (Detects the liquid pipe temperature)	Controls defrosting (start/ end) in heating mode.

TH6	Thermistor (Detects the ambient air temperature)	Detects the ambient temperature and then, controls the fan frequency and liquid level in the accumulator.
TH7(8)	Thermistor (Controls SC)	Controls LEV1 based on the temperature differences between TH 6,7 and 8.
THHS1	Thermistor (Comp inverter radiator plate temperature)	Controls the Comp inverter cooling fan based on the THHS1 temperature.
THHS5	Thermistor (Fan inverter radiator plate temperature)	Controls the Fan inverter cooling fan based on the THHS5 temperature.
63HS	High pressure sensor	Detects the discharge pressure and then protects unit against damage by high pressure.
63LS	Low pressure sensor	Detects the suction pressure and then, senses the refrigerant composition.
Tc	Average of saturation gas temperature of high pressure and saturation liquid temperature of high pressure	For control of compressor frequency and fan speed.
Te	Saturation temperature of low pressure	For control of compressor frequency and fan speed
SCO	Sub-cool at heat exchanger	Variable for control
Tc-TH5		
SCC	Sub-cool at SC coil exit Tc-TH7	Variable for control
SHB	SC coil bypass exit super heat TH8-Te	Variable for control
Vdc	Bus voltage	Bus voltage
Idc	DC trunk line current	DC trunk line current
Iu	Phase-U current	Phase-U current of compressor
Iw	Phase-W current	Phase-W current of compressor

Operation Status Monitor Terminology (PUHY-200/250/300/350/400/450/500YC-A)

Mark	Official Name	Meaning
Ctrl Mode		Control mode for outdoor unit
Ope Mode		Operation mode for outdoor unit
Save		Signal of capacity saving from system controller. figure : % No signal : 100%
Power	Power source frequency	Power source frequency (Hz)
F	Temporary compressor frequency for calculation	Variable for control
F1	Temporary compressor frequency of No.1 Comp for calculation	Variable for control (only for 400 type or over)
F2	Temporary compressor frequency of No.2 Comp for calculation	Variable for control (only for 400 type or over)
AK	Heat exchanger capacity	Variable which determines the size of outdoor heat exchanger
FAN	Fan	Fan capacity of outdoor unit (not proportional to rotational frequency)
DEMAND	ON/OFF demand	Input stop signal of compressor (ON:effective, OFF:ineffective)
DEMAND2	Intermediate demand	Signal of capacity saving (ON:effective, OFF:ineffective) DEMAND=OFF, DEMAND2=OFF: 100% DEMAND=OFF, DEMAND2=ON : 75% DEMAND= ON, DEMAND2=ON : 50% DEMAND= ON, DEMAND2=OFF: 25%
SNOW	Snow sensor	Input run signal of outdoor unit fan (As compressor stopped) (ON:effective, OFF:ineffective)
NIGHT	Night mode	Decreases frequency of outdoor unit fan (ON:effective, OFF:ineffective)
Qj(C)	Total capacity code (cool)	Cooling indoor unit capacity
Qj(H)	Total capacity code (heat)	Heating indoor unit capacity
LEV1	SC coil LEV opening	Adjusts refrigerant in the bypass pipe from liquid pipe in the outdoor unit in cooling mode.
21S4a	4-way valve	Switches the cooling/heating cycle (0:Cooling, 1:Heating)
21S4b	4-way valve	Capacity control of heat exchanger (Gas side) (only for 400 type or over)
SV1	Solenoid valve output (Bypass between discharge pipe and suction pipe)	The discharge pressure control
SV3	Solenoid valve output (Bypass between discharge pipe and suction pipe)	Protects compressor when No.2 compressor stops. (only for 400 type or over)
SV5b	Solenoid valve output	Capacity control of heat exchanger (Liquid side). (only for 400 type or over)
52F	Contactator	ON/OFF switch of No.2 fan (only for 400 type or over)
Rep	Repeater output	Prohibit(0)/Permit(1) the communication with centralized control system
TH11	Thermistor (Detects discharge temperature)	Detects discharge temperature for protection of No.1 compressor.
TH12	Thermistor (Detects discharge temperature)	Detects discharge temperature for protection of No.2 compressor. (only for 400 type or over)
TH5	Thermistor (Detects the liquid pipe temperature)	Controls defrosting (start/ end) in heating mode.
TH6	Thermistor (Detects the ambient air temperature)	Detects the ambient temperature and then, controls the fan frequency and liquid level in the accumulator.
TH7(8)	Thermistor (Controls SC)	Controls LEV1 based on the temperature differences between TH 6,7 and 8.
THHS1	Thermistor (Comp inverter radiator plate temperature)	Controls the Comp inverter cooling fan based on the THHS1 temperature.
THHS5	Thermistor (Fan inverter radiator plate temperature)	Controls the Fan inverter cooling fan based on the THHS5 temperature.
63HS	High pressure sensor	Detects the discharge pressure and then protects unit against da

		mage by high pressure.
63LS	Low pressure sensor	Detects the suction pressure and then, senses the refrigerant composition.
Tc	Average of saturation gas temperature of high pressure and saturation liquid temperature of high pressure	For control of compressor frequency and fan speed.
Te	Saturation temperature of low pressure	For control of compressor frequency and fan speed
SCO	Sub-cool at heat exchanger Tc-TH5	Variable for control
SCC	Sub-cool at SC coil exit Tc-TH7	Variable for control
SHB	SC coil bypass exit super heat	Variable for control
TH8-Te		
Vdc	Bus voltage	Bus voltage
Idc	DC trunk line current	DC trunk line current
Iu	Phase-U current	Phase-U current of compressor
Iw	Phase-W current	Phase-W current of compressor

Operation Status Monitor Terminology (PUHY-P200/250/300/350/400/450/500/550/600/650/700YC-A)

Mark	Official Name	Meaning
Ctrl Mode		Control mode for outdoor unit
Ope Mode		Operation mode for outdoor unit
Save		Signal of capacity saving from system controller. figure : % No signal : 100%
Power	Power source frequency	Power source frequency (Hz)
F	Temporary compressor frequency for calculation	Variable for control
F1	Temporary compressor frequency of No.1 Comp for calculation	Variable for control (only for P450 type or over)
F2	Temporary compressor frequency of No.2 Comp for calculation	Variable for control (only for P450 type or over)
AK	Heat exchanger capacity	Variable which determines the size of outdoor heat exchanger
FAN	Fan	Fan capacity of outdoor unit (not proportional to rotational frequency)
DEMAND	ON/OFF demand	Input stop signal of compressor (ON:effective OFF:ineffective)
DEMAND2	Intermediate demand	Signal of capacity saving (ON:effective OFF:ineffective) DEMAND=OFF, DEMAND2=OFF: 100% DEMAND=OFF, DEMAND2=ON : 75% DEMAND= ON, DEMAND2=ON : 50% DEMAND= ON, DEMAND2=OFF: 25%
SNOW	Snow sensor	Input run signal of outdoor unit fan (As compressor stopped) (ON:effective OFF:ineffective)
NIGHT	Night mode	Decreases frequency of outdoor unit fan (ON:effective OFF:ineffective)
Qj(C)	Total capacity code (cool)	Cooling indoor unit capacity
Qj(H)	Total capacity code (heat)	Heating indoor unit capacity
LEV1	SC coil LEV opening	Adjusts refrigerant in the bypass pipe from liquid pipe in the outdoor unit in cooling mode.
21S4a	4-way valve	Switches the cooling/heating cycle (0:Cooling, 1:Heating)
21S4b	4-way valve	Capacity control of heat exchanger (Gas side) (only for P450 type or over)
SV1	Solenoid valve output (Bypass between discharge pipe and suction pipe)	The discharge pressure control
SV3	Solenoid valve output (Bypass between discharge pipe and suction pipe)	Protects compressor when No.2 compressor stops. (only for P450 type or over)
SV5b	Solenoid valve output	Capacity control of heat exchanger (Liquid side). (only for P450 type or over)
52F	Contactator	ON/OFF switch of No.2 fan (only for P450 type or over)
Rep	Repeater output	Prohibit(0)/Permit(1) the communication with centralized control system
TH11	Thermistor (Detects discharge temperature)	Detects discharge temperature for protection of No.1 compressor.
TH12	Thermistor (Detects discharge temperature)	Detects discharge temperature for protection of No.2 compressor. (only for P450 type or over)
TH5	Thermistor (Detects the liquid pipe temperature)	Controls defrosting (start/ end) in heating mode.
TH6	Thermistor (Detects the ambient air temperature)	Detects the ambient temperature and then, controls the fan frequency and liquid level in the accumulator.
TH7(8)	Thermistor (Controls SC)	Controls LEV1 based on the temperature differences between TH 6,7 and 8.
THHS1	Thermistor (Comp inverter radiator plate temperature)	Controls the Comp inverter cooling fan based on the THHS1 temperature.
THHS5	Thermistor (Fan inverter radiator plate temperature)	Controls the Fan inverter cooling fan based on the THHS5 temperature.
63HS	High pressure sensor	Detects the discharge pressure and then protects unit against da

		mage by high pressure.
63LS	Low pressure sensor	Detects the suction pressure and then, senses the refrigerant composition.
Tc	Average of saturation gas temperature of high pressure and saturation liquid temperature of high pressure	For control of compressor frequency and fan speed.
Te	Saturation temperature of low pressure	For control of compressor frequency and fan speed
SCO	Sub-cool at heat exchanger Tc-TH5	Variable for control
SCC	Sub-cool at SC coil exit Tc-TH7	Variable for control
SHB	SC coil bypass exit super heat	Variable for control
TH8-Te		
Vdc	Bus voltage	Bus voltage
Idc	DC trunk line current	DC trunk line current
Iu	Phase-U current	Phase-U current of compressor
Iw	Phase-W current	Phase-W current of compressor

Operation Status Monitor Terminology (PUHY-P300/350/400YCSM-A)

Mark	Official Name	Meaning
Ctrl Mode		Control mode for outdoor unit
Ope Mode		Operation mode for outdoor unit
Save		Signal of capacity saving from system controller. figure : % No signal : 100%
Power	Power source frequency	Power source frequency (Hz)
F	Temporary compressor frequency for calculation	Variable for control
AK	Heat exchanger capacity	Variable which determines the size of outdoor heat exchanger
DEMAND	ON/OFF demand	Input stop signal of compressor (ON:effective, OFF:ineffective)
DEMAND2	Intermediate demand	Signal of capacity saving (ON:effective, OFF:ineffective) DEMAND=OFF, DEMAND2=OFF: 100% DEMAND=OFF, DEMAND2=ON : 75% DEMAND= ON, DEMAND2=ON : 50% DEMAND= ON, DEMAND2=OFF: 25%
NIGHT	Night mode	Decreases frequency of outdoor unit fan (ON:effective, OFF:ineffective)
Qj(C)	Total capacity code (cool)	Cooling indoor unit capacity
Qj(H)	Total capacity code (heat)	Heating indoor unit capacity
LEV1	SC coil LEV opening	Adjusts refrigerant in the bypass pipe from liquid pipe in the outdoor unit in cooling mode.
LEV2	Cool down inverter LEV opening	Cool down inverter
21S4a	4-way valve	Switches the cooling/heating cycle (0:Cooling, 1:Heating)
SV1	Solenoid valve output	Bypass between discharge pipe and suction pipe
SV4a	Solenoid valve output	Heat exchanger capacity control
SV4b	Solenoid valve output	Heat exchanger capacity control
SV4c	Solenoid valve output	Heat exchanger capacity control
SV4d	Solenoid valve output	Heat exchanger bypass ON/OFF
SV5a	Solenoid valve output	Heat exchanger capacity control (only for P400/500YSGM-A type)
SV5b	Solenoid valve output	Heat exchanger capacity control (only for P400/500YSGM-A type)
SV7a	Solenoid valve output	Heat exchanger capacity control
SV7b	Solenoid valve output	Heat exchanger capacity control
SV7c	Solenoid valve output	Heat exchanger capacity control
UNIT_ON/OFF	ON/OFF-output	ON/OFF-monitor (TB8-1,2P)
Rep	Repeater output	Prohibit(0)/Permit(1) the communication with centralized control system
TH11	Thermistor (Detects discharge temperature)	Detects discharge temperature for protection of No.1 compressor.
TH5	Thermistor (Detects the liquid pipe temperature)	Controls defrosting (start/ end) in heating mode.
TH6	Thermistor (Detects the ambient air temperature)	Detects the ambient temperature and then, controls the fan frequency and liquid level in the accumulator.
TH7(8)	Thermistor (Controls SC)	Controls LEV1 based on the temperature differences between TH 6,7 and 8.
TH9	Thermistor (Freeze prevention sensor)	Detects the water heat exchanger temperature and then, carries out freeze prevention control.
THINV	Thermistor (Outlet of heat exchanger for cool down inverter)	Controls a capacity of heat exchanger for cool down inverter depends on a temperature of THINV.
THHS1	Thermistor (Comp inverter radiator plate temperature)	Controls the Comp inverter cooling fan based on the THHS1 temperature.
63HS	High pressure sensor	Detects the discharge pressure and then protects unit against damage by high pressure.
63LS	Low pressure sensor	Detects the suction pressure and then, protects unit against damage by low pressure.
Tc	Average of saturation gas temperature of high pressure and saturation liquid temperature of high pressure	For control of compressor frequency and fan speed.
Te	Saturation temperature of low pressure	For control of compressor frequency and fan speed.

Vdc	Bus voltage	Bus voltage
Idc	DC trunk line current	DC trunk line current
Iu	Phase-U current	Phase-U current of compressor
Iw	Phase-W current	Phase-W current of compressor

Operation Status Monitor Terminology

(PUHY-P450/500/550/600/650YMM(C)-A, PUHY-P400/650YSM(C)-A, PUHY-P450/500/550/600/650YCSM-A, PUHY-P450/600YCSS-A)

Mark	Official Name	Meaning
Primality		Indicates whether the unit is primary or secondary.
Ctrl Mode		Control mode for outdoor unit
Ope Mode		Operation mode for outdoor unit
Save		Signal of capacity saving from system controller. figure : % No signal : 100%
Power	Power source frequency	Power source frequency (Hz)
F	Temporary compressor frequency for calculation	Variable for control (Total frequency : Foc+Fos)
Foc	Temporary compressor frequency for calculation	Variable for control (Total frequency of OC unit)
Fos	Temporary compressor frequency for calculation	Variable for control (Total frequency of OS unit)
F1	Temporary compressor frequency of No.1 Comp for calculation	Variable for control
F2	Temporary compressor frequency of No.2 Comp for calculation	Variable for control
AK	Heat exchanger capacity	Variable which determines the size of outdoor heat exchanger
FAN	Fan	Fan capacity of outdoor unit (not proportional to rotational frequency)
DEMAND	ON/OFF demand	Input stop signal of compressor (ON:effective, OFF:ineffective)
DEMAND2	Intermediate demand	Signal of capacity saving (ON:effective, OFF:ineffective) DEMAND=OFF, DEMAND2=OFF: 100% DEMAND=OFF, DEMAND2=ON : 75% DEMAND= ON, DEMAND2=ON : 50% DEMAND= ON, DEMAND2=OFF: 25%
SNOW	Snow sensor	Input run signal of outdoor unit fan (As compressor stopped) (ON:effective, OFF:ineffective)
NIGHT	Night mode	Decreases frequency of outdoor unit fan (ON:effective, OFF:ineffective)
Qj(C)	Total capacity code (cool)	Cooling indoor unit capacity
Qj(H)	Total capacity code (heat)	Heating indoor unit capacity
LEV1	SC coil LEV opening	Adjusts refrigerant in the bypass pipe from liquid pipe in the outdoor unit in cooling mode.
21S4a	4-way valve	Switches the cooling/heating cycle (0:Cooling, 1:Heating)
21S4b	4-way valve	Capacity control of heat exchanger (Gas side)
21S4c	4-way valve	Capacity control of heat exchanger (Gas side) Only for PUHY-PYMM-A and PUHY-PYSM-A type
SV1	Solenoid valve output (Bypass between discharge pipe and suction pipe)	The discharge pressure control
SV3	Solenoid valve output (Bypass between discharge pipe and suction pipe)	Protects compressor when No.2 compressor stops.
SV5b	Solenoid valve output	Capacity control of heat exchanger (Liquid side).
SV5c	Solenoid valve output	Capacity control of heat exchanger (Liquid side). Only for PUHY-PYMM-A and PUHY-PYSM-A type
SV5d	Solenoid valve output	Closes when outdoor unit stops.
52F	Contactors	ON/OFF switch of No.2 fan
Rep	Repeater output	Prohibit(0)/Permit(1) the communication with centralized control system
TH11	Thermistor (Detects discharge temperature)	Detects discharge temperature for protection of No.1 compressor.
TH12	Thermistor (Detects discharge temperature)	Detects discharge temperature for protection of No.2 compressor.
TH5	Thermistor (Detects the liquid pipe temperature)	Controls defrosting (start/ end) in heating mode.
TH6	Thermistor (Detects the ambient air temperature)	Detects the ambient temperature and then, controls the fan frequency and liquid level in the accumulator.

TH7(8)	Thermistor (Controls SC)	Controls LEV1 based on the temperature differences between TH 6,7 and 8.
THHS1	Thermistor (Comp inverter radiator plate temperature)	Controls the Comp inverter cooling fan based on the THHS1 temperature.
THHS5	Thermistor (Fan inverter radiator plate temperature)	Controls the Fan inverter cooling fan based on the THHS5 temperature.
63HS	High pressure sensor	Detects the discharge pressure and then protects unit against damage by high pressure.
63LS	Low pressure sensor	Detects the suction pressure and then, senses the refrigerant composition.
Tc	Average of saturation gas temperature of high pressure and saturation liquid temperature of high pressure	For control of compressor frequency and fan speed.
Te	Saturation temperature of low pressure	For control of compressor frequency and fan speed
SCO	Sub-cool at heat exchanger Tc-TH5	Variable for control
SCC	Sub-cool at SC coil exit Tc-TH7	Variable for control
SHB	SC coil bypass exit super heat TH8-Te	Variable for control
Vdc	Bus voltage	Bus voltage
Idc	DC trunk line current	DC trunk line current
Iu	Phase-U current	Phase-U current of compressor
Iw	Phase-W current	Phase-W current of compressor

Operation Status Monitor Terminology (PQHY-P200/250YEM-A)

Mark	Official Name	Meaning
Control mode		Control mode for outdoor unit
Operation mode		Operation mode for outdoor unit
F	Compressor frequency	Compressor frequency
AK	Heat exchanger capacity	Variable which determine the size of outdoor heat exchanger
AL	Accumulator level	Liquid level in the accumulation (0: A little, 1: Medium, 2: Much(overcharge))
Qj(C)	Total capacity code (cool)	Cooling indoor unit capacity
Qj(H)	Total capacity code (heat)	Heating indoor unit capacity
SLEV	Oil return LEV opening	Adjusts the amount of liquid refrigerant and oil returned from the accumulator
LEV1	SC coil LEV opening	Adjusts refrigerant in the bypass pipe from liquid pipe in the outdoor unit in cooling mode.
LEV2	Cool down inverter LEV opening	Cool down inverter
21S4	4-way valve	Switches the cooling/heating cycle (0:Cooling, 1:Heating)
SV1	Solenoid valve output (Bypass between discharge pipe and suction pipe)	Returns oil from the oil separator
SV2	Solenoid valve output (Bypass between discharge pipe and suction pipe)	Controls capacity and restricts the high pressure (Frequency control backup)
SV3	Solenoid valve output (Capacity control of heat exchanger)	Capacity control of heat exchanger
SV4	Solenoid valve output (Capacity control of heat exchanger)	Capacity control of heat exchanger
SV5	Solenoid valve output (Capacity control of heat exchanger)	Capacity control of heat exchanger
SV6	Solenoid valve output (Capacity control of heat exchanger)	Capacity control of heat exchanger
SV71	Solenoid valve output (Capacity control of heat exchanger)	Capacity control of heat exchanger
SV72	Solenoid valve output (Capacity control of heat exchanger)	Capacity control of heat exchanger
SV73	Solenoid valve output (Capacity control of heat exchanger)	Capacity control of heat exchanger
UNIT ON/OFF	ON/OFF-output	ON/OFF-monitor (TB8-1,2P)
Repeater	Repeater output	Prohibit(0)/Permit(1) the Communication with centralized control system
TH1	Thermistor (Detects discharge temperature)	Detects the discharge temperature for the high pressure protection.
TH2	Thermistor (Detects saturated evaporation temperature)	Detects saturated temperature and then, control the compressor frequency and liquid level in the accumulator
TH5	Thermistor (Detects the liquid pipe temperature)	Controls compressor frequency, controls defrosting and detects the liquid level in heating mode, detects the sub-cool at the heat exchanger exit in combination with 63 HS data, and controls LEV1.
TH6	Thermistor (Detects the ambient air temperature)	Detects the ambient temperature and then, controls the liquid level in the accumulator, and the opening LEV pulse for oil return.
TH7	Thermistor (Controls SC)	Controls LEV1 based on the temperature differences between TH 6,7 and 8.
TH8	Thermistor (Controls SC)	Controls LEV1 based on the temperature differences between TH 6,7 and 8.
TH9	Thermistor (Composition sensing)	Senses the refrigerant composition based on TH2, TH9 and 63LS.
TH10	Thermistor (Lower compressor shell)	Detects the oil temperature
THHS	Thermistor (Inverter radiator plate temperature)	Detects the inverter radiator plate temperature for protection of inverter.

	ature)	
THINV	Thermistor (Outlet of heat exchanger for cool down inverter)	Controls a capacity of heat exchanger for cool down inverter depends on a temperature of THINV.
63HS	High pressure sensor	Detects the discharge pressure and then protects unit against damage by high pressure.
63LS	Low pressure sensor	Detects the suction pressure and then, senses the refrigerant composition.
A-OC	Refrigerant composition(R32)	Real percentage of R32
A-OC*	Refrigerant composition(R32)	Calculated percentage of R32
Tc	Average of saturation gas temperature of high pressure and saturation liquid temperature of high pressure	For control of compressor frequency and fan speed.
Te	Saturation temperature of low pressure	Same as TH2

Operation Status Monitor Terminology (PQHY-P200/250YGM-A, PQHY-P400/500YSGM-A)

Mark	Official Name	Meaning
Ctrl Mode		Control mode for outdoor unit
Ope Mode		Operation mode for outdoor unit
Save		Signal of capacity saving from system controller. figure : % No signal : 100%
Power	Power source frequency	Power source frequency (Hz)
F	Temporary compressor frequency for calculation	Variable for control
AK	Heat exchanger capacity	Variable which determines the size of outdoor heat exchanger
DEMAND	ON/OFF demand	Input stop signal of compressor (ON:effective OFF:ineffective)
DEMAND2	Intermediate demand	Signal of capacity saving (ON:effective OFF:ineffective) DEMAND=OFF, DEMAND2=OFF: 100% DEMAND=OFF, DEMAND2=ON : 75% DEMAND= ON, DEMAND2=ON : 50% DEMAND= ON, DEMAND2=OFF: 25%
NIGHT	Night mode	Decreases frequency of outdoor unit fan (ON:effective OFF:ineffective)
Qj(C)	Total capacity code (cool)	Cooling indoor unit capacity
Qj(H)	Total capacity code (heat)	Heating indoor unit capacity
LEV1	SC coil LEV opening	Adjusts refrigerant in the bypass pipe from liquid pipe in the outdoor unit in cooling mode.
LEV2	Cool down inverter LEV opening	Cool down inverter
21S4a	4-way valve	Switches the cooling/heating cycle (0:Cooling, 1:Heating)
SV1	Solenoid valve output	Bypass between discharge pipe and suction pipe
SV4a	Solenoid valve output	Heat exchanger capacity control
SV4b	Solenoid valve output	Heat exchanger capacity control
SV4c	Solenoid valve output	Heat exchanger capacity control
SV4d	Solenoid valve output	Heat exchanger bypass ON/OFF
SV5a	Solenoid valve output	Heat exchanger capacity control (only for P400 type or over)
SV5b	Solenoid valve output	Heat exchanger capacity control (only for P400 type or over)
SV7a	Solenoid valve output	Heat exchanger capacity control
SV7b	Solenoid valve output	Heat exchanger capacity control
SV7c	Solenoid valve output	Heat exchanger capacity control
UNIT_ON/OFF	ON/OFF-output	ON/OFF-monitor (TB8-1,2P)
Rep	Repeater output	Prohibit(0)/Permit(1) the communication with centralized control system
TH11	Thermistor (Detects discharge temperature)	Detects discharge temperature for protection of No.1 compressor.
TH5	Thermistor (Detects the liquid pipe temperature)	Controls defrosting (start/ end) in heating mode.
TH6	Thermistor (Detects the ambient air temperature)	Detects the ambient temperature and then, controls the fan frequency and liquid level in the accumulator.
TH7(8)	Thermistor (Controls SC)	Controls LEV1 based on the temperature differences between TH 6,7 and 8.
TH9	Thermistor (Freeze prevention sensor)	Detects the water heat exchanger temperature and then, carries out freeze prevention control.
THINV	Thermistor (Outlet of heat exchanger for cool down inverter)	Controls a capacity of heat exchanger for cool down inverter depends on a temperature of THINV.
THHS1	Thermistor (Comp inverter radiator plate temperature)	Controls the Comp inverter cooling fan based on the THHS1 temperature.
63HS	High pressure sensor	Detects the discharge pressure and then protects unit against damage by high pressure.
63LS	Low pressure sensor	Detects the suction pressure and then, protects unit against damage by low pressure.
Tc	Average of saturation gas temperature of high pressure and saturation liquid temperature of high pressure	For control of compressor frequency and fan speed.
Te	Saturation temperature of low pressure	For control of compressor frequency and fan speed.

Vdc	Bus voltage	Bus voltage
Idc	DC trunk line current	DC trunk line current
Iu	Phase-U current	Phase-U current of compressor
Iw	Phase-W current	Phase-W current of compressor

Operation Status Monitor Terminology (PURY-200/250YM*)

Mark	Official Name	Meaning
Control mode		Control mode for outdoor unit
Running mode		Running mode for outdoor unit
Capacity save		Capacity save signal from host SC Unit: % Non receiving status: 100%
F/	Low frequency	Control variable
Hz	Actual frequency	Compressor operating frequency
AK	Heater exchange capacity	Control variable to determine the size of outdoor heat exchanger
AL	Accumulator level	Liquid level of accumulation (0:Insufficient 1:Proper 2:Over filling)
FAN	Fan	Fan capacity of outdoor unit (not in proportion to rotation frequency)
Demand	Connecting point demand	Compressor stop (1: Input 0: No input)
SNOW	Snow sensor	Outdoor fan forced operation input (only during compressor off) (1: Input 0: No input)
Night	Night mode	Outdoor fan max. rotational frequency reducing input (1: Input 0: No input)
Qj(C)	Total capacity code (Cool)	Cool only indoor unit capacity
Qj(H)	Total capacity code (Heat)	Heat pump indoor unit capacity
SLEV	Oil return LEV opening	Adjusts the amount of liquid refrigerant(oil) returned from the accumulator
21S4	4 way valve	4 way valve
SV1	Solenoid valve output (discharge-suction bypass)	Returns oil from the oil separator Restricts the rise in the discharge pressure
SV2	Solenoid valve output (Capacity control-full load)	Switches the compressor unload/full load
SV3	Solenoid valve output (Capacity control-unload)	Switches the compressor unload/full load
SV4	Solenoid valve output (Discharge-suction bypass)	Controls capacity and restricts the high pressure (Frequency control backup)
SV5	Solenoid valve output (liquid bypass)	Restricts the rise in the discharge temperature and bypass circuit at defrosting
SV6A	Solenoid valve output (Capacity control of heat exchanger)	Capacity control of heat exchanger
SV6B	Solenoid valve output (Capacity control of heat exchanger)	Capacity control of heat exchanger
SV6C	Solenoid valve output (Capacity control of heat exchanger)	Capacity control of heat exchanger
SV6D	Solenoid valve output (Capacity control of heat exchanger)	Capacity control of heat exchanger
SC6E	Solenoid valve output (Capacity control of heat exchanger)	Capacity control of heat exchanger
SV7	Solenoid valve output (Heat exchanger bypass)	Bypass control of heat exchanger
Repeater	Repeater	Permit(1)/Prohibit(0) the communication with central control system
TH1	Thermistor (Detects discharge temperature)	Detects the discharge temperature for the high pressure protection
TH2	Thermistor (Detects saturated evaporation temperature)	Detects the low pressure saturation temperature then, detects liquid level in the accumulator and control the frequency
TH3	Thermistor (Detects the lower liquid level in the accumulator)	Detects the liquid level in the accumulator
TH4	Thermistor (Detects the upper liquid level in the accumulator)	Detects the liquid level in the accumulator
TH5	Thermistor (Detects the pipe temperature)	Frequency control
TH6	Thermistor (Detects the outside air temperature)	Detects the temperature outside, controls the fan and the liquid level heater, set the opening of oil return LEV.

	erature)	
63HS	High pressure sensor	Detects the high pressure for high pressure protection
THHS	Thermistor (Inverter radiator plate temperature)	Controls the inverter cooling fan based on the THHS temperature
THBOX	Thermistor	Determine the TRIAC failure at outdoor fan lock

Operation Status Monitor Terminology (PURY-200/250YMF-B)

Mark	Official Name	Meaning
Control mode		Control mode for outdoor unit
Operation mode		Operation mode for outdoor unit
F	Compressor frequency	Compressor frequency
AK	Heat exchanger capacity	Variable which determine the size of outdoor heat exchanger
AL	Accumulator level	Liquid level in the accumulation (0: A little, 1: Medium, 2: Much(overcharge))
FAN	Fan	Fan capacity of outdoor unit (not proportional to rotational frequency)
Qj(C)	Total capacity code (Cool)	Cooling indoor unit capacity
Qj(H)	Total capacity code (Heat)	Heating indoor unit capacity
SLEV	Oil return LEV opening	Adjusts the amount of liquid refrigerant and oil returned from the accumulator
21S4	4 way valve	Switches the cooling/heating cycle (0:Cooling, 1:Heating)
SV1	Solenoid valve output (Bypass between discharge pipe and suction pipe)	Returns oil from the oil separator
SV2	Solenoid valve output (Bypass between discharge pipe and suction pipe)	Controls capacity and restricts the high pressure (Frequency control backup)
SV3	Solenoid valve output (Capacity control of heat exchanger)	Capacity control of heat exchanger.
SV4	Solenoid valve output (Capacity control of heat exchanger)	Capacity control of heat exchanger.
SV5	Solenoid valve output (Capacity control of heat exchanger)	Capacity control of heat exchanger.
SV6	Solenoid valve output (Capacity control of heat exchanger)	Capacity control of heat exchanger.
Repeater	Repeater output	Prohibit(0)/Permit(1) the Communication with centralized control system
TH1	Thermistor (Detects discharge temperature)	Detects the discharge temperature for the high pressure protection
TH3	Thermistor (Detects lower liquid level in the accumulator)	Detects the liquid level in the accumulator
TH4	Thermistor (Detects upper liquid level in the accumulator)	Detects the liquid level in the accumulator
TH5	Thermistor (Detects the liquid pipe temperature)	For defrost control
TH6	Thermistor (Detects the ambient air temperature)	Detects the ambient temperature and then, controls the fan frequency liquid level in the accumulator, and the opening LEV pulse for oil return
TH7	Thermistor (Detects the liquid pipe temperature)	For defrost control
THHS	Thermistor (Inverter radiator plate temperature)	Controls the inverter cooling fan based on the THHS temperature
63HS	High pressure sensor	Detects the discharge pressure and then protects unit against damage by high pressure
63LS	Low pressure sensor	Detects the suction pressure and then, controls the frequency.
Tc	Average of saturation gas temperature of high pressure and saturation liquid temperature of high pressure	For control of compressor frequency and fan speed
Te	Saturation temperature of low pressure	Same as TH2

Operation Status Monitor Terminology (PURY-P200/250YMF-B)

Mark	Official Name	Meaning
Control mode		Control mode for outdoor unit
Operation mode		Operation mode for outdoor unit
F	Compressor frequency	Compressor frequency
AK	Heat exchanger capacity	Variable which determine the size of outdoor heat exchanger
AL	Accumulator level	Liquid level in the accumulation (0: A little, 1: Medium, 2: Much(overcharge))
FAN	Fan	Fan capacity of outdoor unit (not proportional to rotational frequency)
Qj(C)	Total capacity code (Cool)	Cooling indoor unit capacity
Qj(H)	Total capacity code (Heat)	Heating indoor unit capacity
SLEV	Oil return LEV opening	Adjusts the amount of liquid refrigerant and oil returned from the accumulator
21S4	4 way valve	Switches the cooling/heating cycle (0:Cooling, 1:Heating)
SV1	Solenoid valve output (Bypass between discharge pipe and suction pipe)	Returns oil from the oil separator
SV2	Solenoid valve output (Bypass between discharge pipe and suction pipe)	Controls capacity and restricts the high pressure (Frequency control backup)
SV3	Solenoid valve output (Capacity control of heat exchanger)	Capacity control of heat exchanger.
SV4	Solenoid valve output (Capacity control of heat exchanger)	Capacity control of heat exchanger.
SV5	Solenoid valve output (Capacity control of heat exchanger)	Capacity control of heat exchanger.
SV6	Solenoid valve output (Capacity control of heat exchanger)	Capacity control of heat exchanger.
Repeater	Repeater output	Prohibit(0)/Permit(1) the Communication with centralized control system
TH1	Thermistor (Detects discharge temperature)	Detects the discharge temperature for the high pressure protection
TH2	Thermistor (Detects saturated evaporation temperature)	Detects saturated temperature and then, control the compressor frequency and liquid level in the accumulator.
TH3	Thermistor (Detects lower liquid level in the accumulator)	Detects the liquid level in the accumulator
TH4	Thermistor (Detects upper liquid level in the accumulator)	Detects the liquid level in the accumulator
TH5	Thermistor (Detects the liquid pipe temperature)	For defrost control
TH6	Thermistor (Detects the ambient air temperature)	Detects the ambient temperature and then, controls the fan frequency liquid level in the accumulator, and the opening LEV pulse for oil return
TH7	Thermistor (Detects the liquid pipe temperature)	For defrost control
TH9	Thermistor (Composition sensing)	Senses the refrigerant composition based on TH2, TH9 and 63LS.
TH10	Thermistor (Lower compressor shell)	Detects the oil temperature
THHS	Thermistor (Inverter radiator plate temperature)	Controls the inverter cooling fan based on the THHS temperature
63HS	High pressure sensor	Detects the discharge pressure and then protects unit against damage by high pressure
63LS	Low pressure sensor	Detects the suction pressure and then, senses the refrigerant composition.
A-OC	Refrigerant composition(R32)	Real percentage of R32

A-OC*	Refrigerant composition(R32)	Calculated percentage of R32
Tc	Average of saturation gas temperature of high pressure and saturation liquid temperature of high pressure	For control of compressor frequency and fan speed
Te	Saturation temperature of low pressure	Same as TH2

Operation Status Monitor Terminology (PURY-200/250YMF-C)

Mark	Official Name	Meaning
Control mode		Control mode for outdoor unit
Operation mode		Operation mode for outdoor unit
Save		Signal of capacity saving from system controller. figure : % No signal : 100%
DEMAND	ON/OFF demand	Input stop signal of compressor (1:effective 0:ineffective)
NIGHT	Night mode	Decreases frequency of outdoor unit fan (1:effective 0:ineffective)
F	Compressor frequency	Compressor frequency
AK	Heat exchanger capacity	Variable which determine the size of outdoor heat exchanger
AL	Accumulator level	Liquid level in the accumulation (0: A little, 1: Medium, 2: Much(overcharge))
FAN	Fan	Fan capacity of outdoor unit (not proportional to rotational frequency)
Qj(C)	Total capacity code (cool)	Cooling indoor unit capacity
Qj(H)	Total capacity code (heat)	Heating indoor unit capacity
SLEV	Oil return LEV opening	Adjusts the amount of liquid refrigerant and oil returned from the accumulator
21S4	4-way valve	Switches the cooling/heating cycle (0:Cooling, 1:Heating)
SV1	Solenoid valve output (Bypass between discharge pipe and suction pipe)	Returns oil from the oil separator
SV2	Solenoid valve output (Bypass between discharge pipe and suction pipe)	Controls capacity and restricts the high pressure (Frequency control backup)
SV3	Solenoid valve output (Capacity control of heat exchanger)	Capacity control of heat exchanger
SV4	Solenoid valve output (Capacity control of heat exchanger)	Capacity control of heat exchanger
SV5	Solenoid valve output (Capacity control of heat exchanger)	Capacity control of heat exchanger
SV6	Solenoid valve output (Capacity control of heat exchanger)	Capacity control of heat exchanger
Repeater	Repeater output	Prohibit(0)/Permit(1) the Communication with centralized control system
TH1	Thermistor (Detects discharge temperature)	Detects the discharge temperature for the high pressure protection.
TH5	Thermistor (Detects the liquid pipe temperature)	For defrost control
TH6	Thermistor (Detects the ambient air temperature)	Detects the ambient temperature and then, controls the fan frequency liquid level in the accumulator, and the opening LEV pulse for oil return.
TH7	Thermistor (Detects the liquid pipe temperature)	For defrost control
THHS	Thermistor (Inverter radiator plate temperature)	Controls the inverter cooling fan based on the THHS temperature.
63HS	High pressure sensor	Detects the discharge pressure and then protects unit against damage by high pressure.
63LS	Low pressure sensor	Detects the suction pressure and then, senses the refrigerant composition.
Tc	Average of saturation gas temperature of high pressure and saturation liquid temperature of high pressure	For control of compressor frequency and fan speed
Te	Saturation temperature of low pressure	For control of compressor frequency and fan speed

Operation Status Monitor Terminology (PURY-P200/250YMF-C)

Mark	Official Name	Meaning
Control mode		Control mode for outdoor unit
Operation mode		Operation mode for outdoor unit
Save		Signal of capacity saving from system controller. figure : % No signal : 100%
F	Temporary compressor frequency for calculation	Variable for control
F1	Temporary compressor frequency of NO.1 COMP for calculation	Variable for control
F2	Temporary compressor frequency of NO.2 COMP	Variable for control for calculation
AK	Heat exchanger capacity	Variable which determine the size of outdoor heat exchanger
AL	Accumulator level	Liquid level in the accumulation (0: A little, 1: Medium, 2: Much(overcharge))
FAN1	Fan	Fan capacity of outdoor unit(Fan on a variable capacity unit) (not proportional to rotational frequency)
DEMAND	ON/OFF demand	Input stop signal of compressor (1:effective 0:ineffective)
SNOW	Snow sensor	Input run signal of outdoor unit fan (As compressor stopped) (1:effective 0:ineffective)
NIGHT	Night mode	Decreases frequency of outdoor unit fan (1:effective 0:ineffective)
$\sum Q_j(C)$	Total capacity code (cool)	Cooling indoor unit capacity
$\sum Q_j(H)$	Total capacity code (heat)	Heating indoor unit capacity
SLEV	Oil return LEV opening	Adjusts the amount of liquid refrigerant and oil returned from the accumulator
21S4a/b	4-way valve	Switches the cooling/heating cycle (0:Cooling, 1:Heating)
SV1	Solenoid valve output (Bypass between discharge pipe and suction pipe)	Returns oil from the oil separator
SV22	Solenoid valve output (Capacity control full load)	Switches the capacity control valve inside the compressor (only P 500 type)
SV32	Solenoid valve output (Capacity control unload)	Switches the capacity control valve inside the compressor (only P 500 type)
SV4a	Solenoid valve output	Controls capacity and restricts the high pressure (Frequency control backup) (Bypass between discharge pipe and suction pipe)
SV6a	Solenoid valve output	Hot gas bypass
SV3	Solenoid valve output	Capacity control of heat exchanger
SV4	Solenoid valve output	Capacity control of heat exchanger
SV5	Solenoid valve output	Capacity control of heat exchanger
SV6	Solenoid valve output	Capacity control of heat exchanger
SV7/8	Solenoid valve output	Capacity control of heat exchanger
52F	Contactors	ON/OFF switch of NO.2 fan
Repeater	Repeater output	Prohibit(0)/Permit(1) the Communication with centralized control system
Power		Power source frequency
TH11	Thermistor (Detects discharge temperature)	Detects the discharge temperature for protection of No.1 compressor.
TH12	Thermistor (Detects discharge temperature)	Detects the discharge temperature for protection of No.2 compressor.
TH2	Thermistor (Detects saturated evaporation temperature)	Detects saturated temperature and then, control the compressor frequency and liquid level in the accumulator
TH3	Thermistor (Detects lower liquid level in the accumulator)	Detects the liquid level in the accumulator
TH4	Thermistor (Detects upper liquid level in the accumulator)	Detects the liquid level in the accumulator
TH5	Thermistor (Detects the pipe temperature)	For defrost control
TH6	Thermistor (Detects the ambient air temperature)	Detects the ambient temperature and then, controls the fan frequency, liquid level in the accumulator, and the opening LEV pulse for oil return.

TH7	Thermistor (Detects pipe temperature)	For defrost control
TH9	Thermistor (Composition sensing)	Senses the refrigerant composition based on TH2, TH9 and 63LS
TH10	Thermistor (Lower compressor shell)	Detects the oil temperature
THHS	Thermistor (Inverter radiator plate temperature)	Controls the inverter cooling fan based on the THHS temperature.
63HS	High pressure sensor	Detects the discharge pressure and then protects unit against damage by high pressure.
63LS	Low pressure sensor	Detects the suction pressure and then, senses the refrigerant composition.
A-OC	Refrigerant composition(R32)	Real percentage of R32
A-OC*	Refrigerant composition(R32)	Calculated percentage of R32
Tc	Average of saturation gas temperature of high pressure and saturation liquid temperature of high pressure	For control of compressor frequency and fan speed.
Te	Saturation temperature of low pressure	same as TH2.

Operation Status Monitor Terminology (PURY-P400/500YMF-C)

Mark	Official Name	Meaning
Control mode		Control mode for outdoor unit
Operation mode		Operation mode for outdoor unit
Save		Signal of capacity saving from system controller. figure : % No signal : 100%
F	Temporary compressor frequency for calculation	Variable for control
F1	Temporary compressor frequency of NO.1 COMP for calculation	Variable for control
F2	Temporary compressor frequency of NO.2 COMP	Variable for control for calculation
AK	Heat exchanger capacity	Variable which determine the size of outdoor heat exchanger
AL	Accumulator level	Liquid level in the accumulation (0: A little, 1: Medium, 2: Much(overcharge))
FAN1	Fan	Fan capacity of outdoor unit(Fan on a variable capacity unit) (not proportional to rotational frequency)
DEMAND	ON/OFF demand	Input stop signal of compressor (1:effective 0:ineffective)
SNOW	Snow sensor	Input run signal of outdoor unit fan (As compressor stopped) (1:effective 0:ineffective)
NIGHT	Night mode	Decreases frequency of outdoor unit fan (1:effective 0:ineffective)
$\Sigma Q_j(C)$	Total capacity code (cool)	Cooling indoor unit capacity
$\Sigma Q_j(H)$	Total capacity code (heat)	Heating indoor unit capacity
SLEV	Oil return LEV opening	Adjusts the amount of liquid refrigerant and oil returned from the accumulator
21S4a/b	4-way valve	Switches the cooling/heating cycle (0:Cooling, 1:Heating)
SV1	Solenoid valve output (Bypass between discharge pipe and suction pipe)	Returns oil from the oil separator
SV22	Solenoid valve output (Capacity control full load)	Switches the capacity control valve inside the compressor (only P 500 type)
SV32	Solenoid valve output (Capacity control unload)	Switches the capacity control valve inside the compressor (only P 500 type)
SV4a	Solenoid valve output	Controls capacity and restricts the high pressure (Frequency control backup) (Bypass between discharge pipe and suction pipe)
SV6a	Solenoid valve output	Hot gas bypass
SV3	Solenoid valve output	Capacity control of heat exchanger
SV4	Solenoid valve output	Capacity control of heat exchanger
SV5	Solenoid valve output	Capacity control of heat exchanger
SV6	Solenoid valve output	Capacity control of heat exchanger
SV7/8	Solenoid valve output	Capacity control of heat exchanger
52F	Contactora	ON/OFF switch of NO.2 fan
Repeater	Repeater output	Prohibit(0)/Permit(1) the Communication with centralized control system
Power		Power source frequency
TH11	Thermistor (Detects discharge temperature)	Detects the discharge temperature for protection of No.1 compressor.
TH12	Thermistor (Detects discharge temperature)	Detects the discharge temperature for protection of No.2 compressor.
TH2	Thermistor (Detects saturated evaporation temperature)	Detects saturated temperature and then, control the compressor frequency and liquid level in the accumulator
TH3	Thermistor (Detects lower liquid level in the accumulator)	Detects the liquid level in the accumulator
TH4	Thermistor (Detects upper liquid level in the accumulator)	Detects the liquid level in the accumulator
TH5	Thermistor (Detects the pipe temperature)	For defrost control
TH6	Thermistor (Detects the ambient air temperature)	Detects the ambient temperature and then, controls the fan frequency, liquid level in the accumulator, and the opening LEV pulse for oil return.

TH7	Thermistor (Detects pipe temperature)	For defrost control
TH9	Thermistor (Composition sensing)	Senses the refrigerant composition based on TH2, TH9 and 63LS
TH10	Thermistor (Lower compressor shell)	Detects the oil temperature
THHS	Thermistor (Inverter radiator plate temperature)	Controls the inverter cooling fan based on the THHS temperature.
63HS	High pressure sensor	Detects the discharge pressure and then protects unit against damage by high pressure.
63LS	Low pressure sensor	Detects the suction pressure and then, senses the refrigerant composition.
A-OC	Refrigerant composition(R32)	Real percentage of R32
A-OC*	Refrigerant composition(R32)	Calculated percentage of R32
Tc	Average of saturation gas temperature of high pressure and saturation liquid temperature of high pressure :For control of compressor frequency and fan speed.	
Te	Saturation temperature of low pressure :same as TH2.	

Operation Status Monitor Terminology (PURY-200/250YEM-A)

Mark	Official Name	Meaning
Ctrl Mode		Control mode for outdoor unit
Ope Mode		Operation mode for outdoor unit
Save		Signal of capacity saving from system controller. figure : % No signal : 100%
DEMAND	ON/OFF demand	Input stop signal of compressor (ON : effective OFF : ineffective)
DEMAND2		Signal of capacity saving (ON : effective OFF : ineffective)
SNOW	Snow sensor	Input run signal of outdoor unit fan (As compressor stopped) (ON : effective OFF : ineffective)
NIGHT	Night mode	Decreases frequency of outdoor unit fan (ON : effective OFF : ineffective)
F	Compressor frequency	Compressor frequency
AK	Heat exchanger capacity	Variable which determine the size of outdoor heat exchanger
AL	Accumulator level	Liquid level in the accumulation (0: A little, 1: Medium, 2: Much(overcharge))
FAN	Fan	Fan capacity of outdoor unit (not proportional to rotational frequency)
Qj(C)	Total capacity code (cool)	Cooling indoor unit capacity
Qj(H)	Total capacity code (heat)	Heating indoor unit capacity
21S4	4-way valve	Switches the cooling/heating cycle (0:Cooling, 1:Heating)
SV1	Solenoid valve output (Bypass between discharge pipe and suction pipe)	Returns oil from the oil separator
SV3	Solenoid valve output (Capacity control of heat exchanger)	Capacity control of heat exchanger
SV4	Solenoid valve output (Capacity control of heat exchanger)	Capacity control of heat exchanger
SV5	Solenoid valve output (Capacity control of heat exchanger)	Capacity control of heat exchanger
SV6	Solenoid valve output (Capacity control of heat exchanger)	Capacity control of heat exchanger
Repeater	Repeater output	Prohibit(0)/Permit(1) the Communication with centralized control system
TH1	Thermistor (Detects discharge temperature)	Detects the discharge temperature for the high pressure protection.
TH5	Thermistor (Detects the liquid pipe temperature)	For defrost control
TH6	Thermistor (Detects the ambient air temperature)	Detects the ambient temperature and then, controls the fan frequency and liquid level in the accumulator.
TH7	Thermistor (Detects the liquid pipe temperature)	For defrost control
THHS	Thermistor (Inverter radiator plate temperature)	Controls the inverter cooling fan based on the THHS temperature.
63HS	High pressure sensor	Detects the discharge pressure and then protects unit against damage by high pressure.
63LS	Low pressure sensor	Detects the suction pressure and then, senses the refrigerant composition.
Tc	Average of saturation gas temperature of high pressure and saturation liquid temperature of high-pressure	
Te	Saturation temperature of low pressure	
Vdc	Bus voltage	Bus voltage
Idc	DC trunk line current	DC trunk line current
Iu	Phase-U current	Phase-U current of compressor
Iw	Phase-W current	Phase-W current of compressor

Operation Status Monitor Terminology (PURY-P200/250YEM-A)

Mark	Official Name	Meaning
Ctrl Mode		Control mode for outdoor unit
Ope Mode		Operation mode for outdoor unit
Save		Signal of capacity saving from system controller. figure : % No signal : 100%
DEMAND	ON/OFF demand	Input stop signal of compressor (ON : effective OFF : ineffective)
DEMAND2		Signal of capacity saving (ON : effective OFF : ineffective)
SNOW	Snow sensor	Input run signal of outdoor unit fan (As compressor stopped) (ON : effective OFF : ineffective)
NIGHT	Night mode	Decreases frequency of outdoor unit fan (ON : effective OFF : ineffective)
F	Compressor frequency	Compressor frequency
AK	Heat exchanger capacity	Variable which determine the size of outdoor heat exchanger
AL	Accumulator level	Liquid level in the accumulation (0: A little, 1: Medium, 2: Much(overcharge))
FAN	Fan	Fan capacity of outdoor unit (not proportional to rotational frequency)
Qj(C)	Total capacity code (cool)	Cooling indoor unit capacity
Qj(H)	Total capacity code (heat)	Heating indoor unit capacity
21S4	4-way valve	Switches the cooling/heating cycle (0:Cooling, 1:Heating)
SV1	Solenoid valve output (Bypass between discharge pipe and suction pipe)	Returns oil from the oil separator
SV3	Solenoid valve output (Capacity control of heat exchanger)	Capacity control of heat exchanger
SV4	Solenoid valve output (Capacity control of heat exchanger)	Capacity control of heat exchanger
SV5	Solenoid valve output (Capacity control of heat exchanger)	Capacity control of heat exchanger
SV6	Solenoid valve output (Capacity control of heat exchanger)	Capacity control of heat exchanger
Repeater	Repeater output	Prohibit(0)/Permit(1) the Communication with centralized control system
TH1	Thermistor (Detects discharge temperature)	Detects the discharge temperature for the high pressure protection.
TH2	Thermistor (Detects saturated evaporation temperature)	Detects saturated temperature and then, control the compressor frequency and liquid level in the accumulator
TH5	Thermistor (Detects the liquid pipe temperature)	For defrost control
TH6	Thermistor (Detects the ambient air temperature)	Detects the ambient temperature and then, controls the fan frequency and liquid level in the accumulator.
TH7	Thermistor (Detects the liquid pipe temperature)	For defrost control
THHS	Thermistor (Inverter radiator plate temperature)	Controls the inverter cooling fan based on the THHS temperature.
63HS	High pressure sensor	Detects the discharge pressure and then protects unit against damage by high pressure.
63LS	Low pressure sensor	Detects the suction pressure and then, senses the refrigerant composition.
A-OC	Refrigerant composition(R32)	Real percentage of R32
A-OC*	Refrigerant composition(R32)	Calculated percentage of R32
Tc	Average of saturation gas temperature of high pressure and saturation liquid temperature	

	ture of high-pressure	
Te	Saturation temperature of low pressure	
Vdc	Bus voltage	Bus voltage
Idc	DC trunk line current	DC trunk line current
Iu	Phase-U current	Phase-U current of compressor
Iw	Phase-W current	Phase-W current of compressor

Operation Status Monitor Terminology (PURY-80/100TMU)

Mark	Official Name	Meaning
Control mode		Control mode for outdoor unit
Operation mode		Operation mode for outdoor unit
Save		Signal of capacity saving from system controller. Figure : % No signal : 100%
DEMAND	ON/OFF demand	Input stop signal of compressor (1:effective 0:ineffective)
NIGHT	Night mode	Decreases frequency of outdoor unit fan (1:effective 0:ineffective)
SNOW	Snow sensor	Input run signal of outdoor unit fan(As compressor stopped) (1:effective 0:ineffective)
F	Compressor frequency	Compressor frequency
AK	Heat exchanger capacity	Variable which determine the size of outdoor heat exchanger
AL	Accumulator level	Liquid level in the accumulation (0: A little, 1: Medium, 2: Much(overcharge))
FAN	Fan	Fan capacity of outdoor unit (not proportional to rotational frequency)
Qj(C)	Total capacity code (cool)	Cooling indoor unit capacity
Qj(H)	Total capacity code (heat)	Heating indoor unit capacity
SLEV	Oil return LEV opening	Adjusts the amount of liquid refrigerant and oil returned from the accumulator
21S4	4-way valve	Switches the cooling/heating cycle (0:Cooling, 1:Heating)
SV1	Solenoid valve output (Bypass between discharge pipe and suction pipe)	Returns oil from the oil separator
SV2	Solenoid valve output (Bypass between discharge pipe and suction pipe)	Controls capacity and restricts the high pressure (Frequency control backup)
SV3	Solenoid valve output (Capacity control of heat exchanger)	Capacity control of heat exchanger
SV4	Solenoid valve output (Capacity control of heat exchanger)	Capacity control of heat exchanger
SV5	Solenoid valve output (Capacity control of heat exchanger)	Capacity control of heat exchanger
SV6	Solenoid valve output (Capacity control of heat exchanger)	Capacity control of heat exchanger
Repeater	Repeater output	Prohibit(0)/Permit(1) the Communication with centralized control system
TH1	Thermistor (Detects discharge temperature)	Detects the discharge temperature for the high pressure protection.
TH5	Thermistor (Detects the liquid pipe temperature)	For defrost control
TH6	Thermistor (Detects the ambient air temperature)	Detects the ambient temperature and then, controls the fan frequency liquid level in the accumulator, and the opening LEV pulse for oil return.
TH7	Thermistor (Detects the liquid pipe temperature)	For defrost control
THHS	Thermistor (Inverter radiator plate temperature)	Controls the inverter cooling fan based on the THHS temperature.
63HS	High pressure sensor	Detects the discharge pressure and then protects unit against damage by high pressure.
63LS	Low pressure sensor	Detects the suction pressure and then, senses the refrigerant composition.
Tc	Average of saturation gas temperature of high pressure and saturation liquid temperature of high pressure	For control of compressor frequency and fan speed.
Te	Saturation temperature of low pressure	For control of compressor frequency and fan speed.

Operation Status Monitor Terminology

(PURY-P200/250/300/350/400YGM-A,PURY-P450/500/550/600/650YGM-A)

Mark	Official Name	Meaning
Ctrl Mode		Control mode for outdoor unit
Ope Mode		Operation mode for outdoor unit
Save		Signal of capacity saving from system controller. figure : % No signal : 100%
Power	Power source frequency	Power source frequency (Hz)
F	Temporary compressor frequency for calculation	Variable for control
F1	Temporary compressor frequency of No.1 Comp for calculation	Variable for control (only for P450 type or over)
F2	Temporary compressor frequency of No.2 Comp for calculation	Variable for control (only for P450 type or over)
AK	Heat exchanger capacity	Variable which determines the size of outdoor heat exchanger
FAN	Fan	Fan capacity of outdoor unit (not proportional to rotational frequency)
DEMAND	ON/OFF demand	Input stop signal of compressor (ON:effective, OFF:ineffective)
DEMAND2	Intermediate demand	Signal of capacity saving (ON:effective, OFF:ineffective) DEMAND=OFF, DEMAND2=OFF: 100% DEMAND=OFF, DEMAND2=ON : 75% DEMAND= ON, DEMAND2=ON : 50% DEMAND= ON, DEMAND2=OFF: 25%
SNOW	Snow sensor	Input run signal of outdoor unit fan (As compressor stopped) (ON:effective, OFF:ineffective)
NIGHT	Night mode	Decreases frequency of outdoor unit fan (ON:effective, OFF:ineffective)
Qj(C)	Total capacity code (cool)	Cooling indoor unit capacity
Qj(H)	Total capacity code (heat)	Heating indoor unit capacity
21S4a	4-way valve	Switches the cooling/heating cycle (0:Cooling, 1:Heating)
21S4b	4-way valve	Heat exchanger capacity control (only for P450 type or over)
SV1	Solenoid valve output	Bypass between discharge pipe and suction pipe
SV2	Solenoid valve output	Bypass between discharge pipe and suction pipe
SV3	Solenoid valve output	Bypass between discharge pipe and suction pipe (only for P450 type or over)
SV4a	Solenoid valve output	Heat exchanger capacity control
SV4b	Solenoid valve output	Heat exchanger capacity control
SV4c	Solenoid valve output	Heat exchanger capacity control
SV4d	Solenoid valve output	Heat exchanger bypass ON/OFF
SV5a	Solenoid valve output	Heat exchanger capacity control (only for P450 type or over)
SV5b	Solenoid valve output	Heat exchanger capacity control (only for P450 type or over)
52F	Contactora	ON/OFF switch of No.2 fan (only for P450 type or over)
Rep	Repeater output	Prohibit(0)/Permit(1) the communication with centralized control system
TH11	Thermistor (Detects discharge temperature)	Detects discharge temperature for protection of No.1 compressor.
TH12	Thermistor (Detects discharge temperature)	Detects discharge temperature for protection of No.2 compressor. (only for P450 type or over)
TH5	Thermistor (Detects the pipe temperature)	Controls defrosting (start/ end) in heating mode.
TH6	Thermistor (Detects the ambient air temperature)	Detects the ambient temperature and then, controls the fan frequency and liquid level in the accumulator.
TH7	Thermistor (Detects pipe temperature)	For defrost control
THHS1	Thermistor (Comp inverter radiator plate temperature)	Controls the Comp inverter cooling fan based on the THHS1 temperature.
THHS5	Thermistor (Fan inverter radiator plate temperature)	Controls the Fan inverter cooling fan based on the THHS5 temperature.

	emperature)	
63HS	High pressure sensor	Detects the discharge pressure and then protects unit against damage by high pressure.
63LS	Low pressure sensor	Detects the suction pressure and then, protects unit against damage by low pressure.
Tc	Average of saturation gas temperature of high pressure and saturation liquid temperature of high pressure	For control of compressor frequency and fan speed.
Te	Saturation temperature of low pressure	For control of compressor frequency and fan speed.
Vdc	Bus voltage	Bus voltage
Idc	DC trunk line current	DC trunk line current
Iu	Phase-U current	Phase-U current of compressor
Iw	Phase-W current	Phase-W current of compressor

Operation Status Monitor Terminology (PQRY-P200/250YMF-B)

Mark	Official Name	Meaning
Control mode		Control mode for outdoor unit
Operation mode		Operation mode for outdoor unit
F	Compressor frequency	Compressor frequency
AK	Heat exchanger capacity	Variable which determine the size of outdoor heat exchanger
AL	Accumulator level	Liquid level in the accumulation (0: A little, 1: Medium, 2: Much(overcharge))
Qj(C)	Total capacity code (cool)	Cooling indoor unit capacity
Qj(H)	Total capacity code (heat)	Heating indoor unit capacity
SLEV	Oil return LEV opening	Adjusts the amount of liquid refrigerant and oil returned from the accumulator
LEV2	Cool down inverter LEV opening	Cool down inverter
21S4	4-way valve	Switches the cooling/heating cycle (0:Cooling, 1:Heating)
SV1	Solenoid valve output (Bypass between discharge pipe and suction pipe)	Returns oil from the oil separator
SV2	Solenoid valve output (Bypass between discharge pipe and suction pipe)	Controls capacity and restricts the high pressure (Frequency control backup)
SV3	Solenoid valve output (Capacity control of heat exchanger)	Capacity control of heat exchanger
SV4	Solenoid valve output (Capacity control of heat exchanger)	Capacity control of heat exchanger
SV5	Solenoid valve output (Capacity control of heat exchanger)	Capacity control of heat exchanger
SV6	Solenoid valve output (Capacity control of heat exchanger)	Capacity control of heat exchanger
SV71	Solenoid valve output (Capacity control of heat exchanger)	Capacity control of heat exchanger
SV72	Solenoid valve output (Capacity control of heat exchanger)	Capacity control of heat exchanger
SV73	Solenoid valve output (Capacity control of heat exchanger)	Capacity control of heat exchanger
UNIT ON/OFF	ON/OFF-output	ON/OFF-monitor (TB8-1,2P)
Repeater	Repeater output	Prohibit(0)/Permit(1) the Communication with centralized control system
TH1	Thermistor (Detects discharge temperature)	Detects the discharge temperature for the high pressure protection.
TH2	Thermistor (Detects saturated evaporation temperature)	Detects saturated temperature and then, control the compressor frequency and liquid level in the accumulator
TH3	Thermistor (Detects lower liquid level in the accumulator)	Detects the liquid level in the accumulator
TH4	Thermistor (Detects upper liquid level in the accumulator)	Detects the liquid level in the accumulator
TH6	Thermistor (Detects the ambient air temperature)	Detects the ambient temperature and then, controls the liquid level in the accumulator, and the opening LEV pulse for oil return.
TH9	Thermistor (Composition sensing)	Senses the refrigerant composition based on TH2, TH9 and 63LS.
TH10	Thermistor (Lower compressor shell)	Detects the oil temperature
THHS	Thermistor (Inverter radiator plate temperature)	Detects the inverter radiator plate temperature for protection of inverter.
THINV	Thermistor (Outlet of heat exchanger for cool down inverter)	Controls a capacity of heat exchanger for cool down inverter depends on a temperature of THINV.

63HS	High pressure sensor	Detects the discharge pressure and then protects unit against damage by high pressure.
63LS	Low pressure sensor	Detects the suction pressure and then, senses the refrigerant composition.
A-OC	Refrigerant composition(R32)	Real percentage of R32
A-OC*	Refrigerant composition(R32)	Calculated percentage of R32
Tc	Average of saturation gas temperature of high pressure and saturation liquid temperature of high pressure	For control of compressor frequency and fan speed.
Te	Saturation temperature of low pressure	Same as TH2

Operation Status Monitor Terminology (PQRY-P200/250YMF-C)

Mark	Official Name	Meaning
Control mode		Control mode for outdoor unit
Operation mode		Operation mode for outdoor unit
F	Compressor frequency	Compressor frequency
AK	Heat exchanger capacity	Variable which determine the size of outdoor heat exchanger
AL	Accumulator level	Liquid level in the accumulation (0: A little, 1: Medium, 2: Much(overcharge))
Qj(C)	Total capacity code (cool)	Cooling indoor unit capacity
Qj(H)	Total capacity code (heat)	Heating indoor unit capacity
SLEV	Oil return LEV opening	Adjusts the amount of liquid refrigerant and oil returned from the accumulator
LEV2	Cool down inverter LEV opening	Cool down inverter
21S4	4-way valve	Switches the cooling/heating cycle (0:Cooling, 1:Heating)
SV1	Solenoid valve output (Bypass between discharge pipe and suction pipe)	Returns oil from the oil separator
SV2	Solenoid valve output (Bypass between discharge pipe and suction pipe)	Controls capacity and restricts the high pressure (Frequency control backup)
SV3	Solenoid valve output (Capacity control of heat exchanger)	Capacity control of heat exchanger
SV4	Solenoid valve output (Capacity control of heat exchanger)	Capacity control of heat exchanger
SV5	Solenoid valve output (Capacity control of heat exchanger)	Capacity control of heat exchanger
SV6	Solenoid valve output (Capacity control of heat exchanger)	Capacity control of heat exchanger
SV71	Solenoid valve output (Capacity control of heat exchanger)	Capacity control of heat exchanger
SV72	Solenoid valve output (Capacity control of heat exchanger)	Capacity control of heat exchanger
SV73	Solenoid valve output (Capacity control of heat exchanger)	Capacity control of heat exchanger
UNIT ON/OFF	ON/OFF-output	ON/OFF-monitor (TB8-1,2P)
Repeater	Repeater output	Prohibit(0)/Permit(1) the Communication with centralized control system
TH1	Thermistor (Detects discharge temperature)	Detects the discharge temperature for the high pressure protection.
TH2	Thermistor (Detects saturated evaporation temperature)	Detects saturated temperature and then, control the compressor frequency and liquid level in the accumulator
TH6	Thermistor (Detects the ambient air temperature)	Detects the ambient temperature and then, controls the liquid level in the accumulator, and the opening LEV pulse for oil return.
TH9	Thermistor (Composition sensing)	Senses the refrigerant composition based on TH2, TH9 and 63LS.
TH10	Thermistor (Lower compressor shell)	Detects the oil temperature
THHS	Thermistor (Inverter radiator plate temperature)	Detects the inverter radiator plate temperature for protection of inverter.
THINV	Thermistor (Outlet of heat exchanger for cool down inverter)	Controls a capacity of heat exchanger for cool down inverter depends on a temperature of THINV.
63HS	High pressure sensor	Detects the discharge pressure and then protects unit against damage by high pressure.
63LS	Low pressure sensor	Detects the suction pressure and then, senses the refrigerant composition.
A-OC	Refrigerant composition(R32)	Real percentage of R32

A-OC*	Refrigerant composition(R32)	Calculated percentage of R32
Tc	Average of saturation gas temperature of high pressure and saturation liquid temperature of high pressure	For control of compressor frequency and fan speed.
Te	Saturation temperature of low pressure	Same as TH2

Operation Status Monitor Terminology (PQRY-P200/250YGM-A, PQRY-P400/500YSGM-A)

Mark	Official Name	Meaning
Ctrl Mode		Control mode for outdoor unit
Ope Mode		Operation mode for outdoor unit
Save		Signal of capacity saving from system controller. figure : % No signal : 100%
Power	Power source frequency	Power source frequency (Hz)
F	Temporary compressor frequency for calculation	Variable for control
AK	Heat exchanger capacity	Variable which determines the size of outdoor heat exchanger
DEMAND	ON/OFF demand	Input stop signal of compressor (ON:effective OFF:ineffective)
DEMAND2	Intermediate demand	Signal of capacity saving (ON:effective OFF:ineffective) DEMAND=OFF, DEMAND2=OFF: 100% DEMAND=OFF, DEMAND2=ON : 75% DEMAND= ON, DEMAND2=ON : 50% DEMAND= ON, DEMAND2=OFF: 25%
NIGHT	Night mode	Decreases frequency of outdoor unit fan (ON:effective OFF:ineffective)
Qj(C)	Total capacity code (cool)	Cooling indoor unit capacity
Qj(H)	Total capacity code (heat)	Heating indoor unit capacity
LEV2	Cool down inverter LEV opening	Cool down inverter
21S4a	4-way valve	Switches the cooling/heating cycle (0:Cooling, 1:Heating)
SV1	Solenoid valve output	Bypass between discharge pipe and suction pipe
SV4a	Solenoid valve output	Heat exchanger capacity control
SV4b	Solenoid valve output	Heat exchanger capacity control
SV4c	Solenoid valve output	Heat exchanger capacity control
SV4d	Solenoid valve output	Heat exchanger bypass ON/OFF
SV5a	Solenoid valve output	Heat exchanger capacity control (only for P400 type or over)
SV5b	Solenoid valve output	Heat exchanger capacity control (only for P400 type or over)
SV7a	Solenoid valve output	Heat exchanger capacity control
SV7b	Solenoid valve output	Heat exchanger capacity control
SV7c	Solenoid valve output	Heat exchanger capacity control
UNIT_ON/OFF	ON/OFF-output	ON/OFF-monitor (TB8-1,2P)
Rep	Repeater output	Prohibit(0)/Permit(1) the communication with centralized control system
TH11	Thermistor (Detects discharge temperature)	Detects discharge temperature for protection of No.1 compressor.
TH6	Thermistor (Detects the ambient air temperature)	Detects the ambient temperature and then, controls the fan frequency and liquid level in the accumulator.
TH9	Thermistor (Freeze prevention sensor)	Detects the water heat exchanger temperature and then, carries out freeze prevention control.
THINV	Thermistor (Outlet of heat exchanger for cool down inverter)	Controls a capacity of heat exchanger for cool down inverter depends on a temperature of THINV.
THHS1	Thermistor (Comp inverter radiator plate temperature)	Controls the Comp inverter cooling fan based on the THHS1 temperature.
63HS	High pressure sensor	Detects the discharge pressure and then protects unit against damage by high pressure.
63LS	Low pressure sensor	Detects the suction pressure and then, protects unit against damage by low pressure.
Tc	Average of saturation gas temperature of high pressure and saturation liquid temperature of high pressure	For control of compressor frequency and fan speed.
Te	Saturation temperature of low pressure	For control of compressor frequency and fan speed.
Vdc	Bus voltage	Bus voltage
Idc	DC trunk line current	DC trunk line current
Iu	Phase-U current	Phase-U current of compressor
Iw	Phase-W current	Phase-W current of compressor

Operation Status Monitor Terminology (PUMY)

<Notes on monitoring the PUMY series units with the Maintenance Tool>

When monitoring the PUMY series of outdoor units with the Maintenance Tool, indeterminate values will appear as the sensor values for models without built-in sensors. See the manuals of the respective models for the presence or absence of sensors.

Mark	Official Name	Meaning
Operation mode		Operation mode
Capacity save		The signal of capacity save from master system controller. unit:% The signal is displayed "100%" under no signal.
FAN	Fan steps	Out door unit fan steps
F/Hz	Compressor frequency	Compressor frequency
SLEV	LEV pulse	It is controlled by the sub cool at outdoor heatexchanger exit in cooling mode. It is opened fully in heating mode. It is backup when the discharge temperature raises abnormality.(Cooling, heating mode)
SC	Sub cool	Sub cool
SN	Sub cool steps	Sub cool steps
Pdm	Target high pressure	Target high pressure
ETm	Target evaporation temperature	Target evaporation temperature
Demand	Contact demand input	The compressor is stopped when the contact is closed. (1:ON 0:OFF)
Night	Night(silent)mode	The compressor maximum frequency is down when the contact of outdoor control board is ON Contact input (1:ON 0:OFF)
Inner	Comp inner thermostat	The thermostat in the compressor is ON when the motor temperature abnormal rises. Input(1:ON 0:OFF)
IPM	IPM abnormal input	It is detected when the overcurrent flows to the IPM, or the IPM temperature abnormal rises. (1:ON 0:OFF)
52C	electromagnetic contactor (inverter main circuit)	52C output On during indoor unit running
21S4	4-way valve	4-way valve
SV1	Solenoid valve output	The bypass of discharge gas
Repeater	Repeater output	It is permission(1) / prohibition(2) of communication with the centralized controllers.
TH1	Thermistor (Detects discharge temperature)	It detects the discharge temperature to control the compressor frequency. It protects the discharge temperature. It is used to calculate the discharge superheat temperature.
TH2	Thermistor	It detects the low pressure saturation temperature to control the compressor frequency.
TH5	Thermistor	It is used to control SLEV pulse in cooling mode. It is used to start the defrost mode in heating mode. (Pipe temperature · Defrost determination)
TH6	Thermistor (Detects the ambient air temperature)	It detects the ambient temperature to control outdoor fan and LEV pulse.
THHS	Thermistor	It detects the power transistor radiator plate temperature for protection of power transistor. (radiator plate temperature)
63HS	High pressure sensor	It detects the discharge pressure to control the compressor frequency and protects unit against damage by high pressure. It is used to calculate the sub cool. (Detects discharge pressure)
Power factor	compressor power factor data	It detects the compressor power factor to control the optimum voltage.
SC1	Sub cool of indoor unit 1	Heating mode Sub cool Cooling mode :Super heat
SC2	Sub cool of indoor unit 2	Heating mode Sub cool Cooling mode :Super heat
SC3	Sub cool of indoor unit 3	Heating mode Sub cool Cooling mode :Super heat
SC4	Sub cool of indoor unit 4	Heating mode Sub cool Cooling mode :Super heat
SC5	Sub cool of indoor unit 5	Heating mode Sub cool Cooling mode :Super heat
SC6	Sub cool of indoor unit 6	Heating mode Sub cool Cooling mode :Super heat

SC7	Sub cool of indoor unit 7	Heating mode Sub cool Cooling mode :Super heat
SC8	Sub cool of indoor unit 8	Heating mode Sub cool Cooling mode :Super heat
LEV1	LEV pulse of indoor unit 1	LEV pulse of indoor unit 1 LEV pulse control from the outdoor unit Cooling mode: It controls the super heat of indoor unit heatexchanger exit Heating mode: It controls the sub cool of indoor unit heatexchanger exit
LEV2	LEV pulse of indoor unit 2	LEV pulse of indoor unit 2 LEV pulse control from the outdoor unit Cooling mode: It controls the super heat of indoor unit heatexchanger exit Heating mode: It controls the sub cool of indoor unit heatexchanger exit
LEV3	LEV pulse of indoor unit 3	LEV pulse of indoor unit 3 LEV pulse control from the outdoor unit Cooling mode: It controls the super heat of indoor unit heatexchanger exit Heating mode: It controls the sub cool of indoor unit heatexchanger exit
LEV4	LEV pulse of indoor unit 4	LEV pulse of indoor unit 4 LEV pulse control from the outdoor unit Cooling mode: It controls the super heat of indoor unit heatexchanger exit Heating mode: It controls the sub cool of indoor unit heatexchanger exit
LEV5	LEV pulse of indoor unit 5	LEV pulse of indoor unit 5 LEV pulse control from the outdoor unit Cooling mode: It controls the super heat of indoor unit heatexchanger exit Heating mode: It controls the sub cool of indoor unit heatexchanger exit
LEV6	LEV pulse of indoor unit 6	LEV pulse of indoor unit 6 LEV pulse control from the outdoor unit Cooling mode: It controls the super heat of indoor unit heatexchanger exit Heating mode: It controls the sub cool of indoor unit heatexchanger exit
LEV7	LEV pulse of indoor unit 7	LEV pulse of indoor unit 7 LEV pulse control from the outdoor unit Cooling mode: It controls the super heat of indoor unit heatexchanger exit Heating mode: It controls the sub cool of indoor unit heatexchanger exit
LEV8	LEV pulse of indoor unit 8	LEV pulse of indoor unit 8 LEV pulse control from the outdoor unit Cooling mode: It controls the super heat of indoor unit heatexchanger exit Heating mode: It controls the sub cool of indoor unit heatexchanger exit

Operation Status Monitor Terminology (PUMY-P100/125/140V/YHM-A, PUMY-P100/125/140YHM-B)

<Notes on monitoring the PUMY series units with the Maintenance Tool>

When monitoring the PUMY series of outdoor units with the Maintenance Tool, indeterminate values will appear as the sensor values for models without built-in sensors. See the manuals of the respective models for the presence or absence of sensors.

Mark	Official Name	Meaning
Operation mode		Operation mode
FAN	Fan steps	Out door unit fan steps
F/Hz	Compressor frequency	Compressor frequency
SC	Sub cool	Sub cool
SCm	Target sub cool	Target sub cool (cooling)
Pdm	Target high pressure	Target high pressure(heating)
ETm	Target evaporation temperature	Target evaporation temperature(cooling)
52C	electromagnetic contactor (inverter main circuit)	52C output
21S4	4-way valve	4-way valve
SV1(Pd)	Solenoid valve output	The bypass of discharge gas (for pd back up)
SV1(Td)	Solenoid valve output	The bypass of discharge gas(for td back up)
SV1(Stop)	Solenoid valve output	The bypass of discharge gas(for stop mode pressure equalization)
TH4	Thermistor (Detects discharge temperature)	It detects the discharge temperature to control the compressor frequency. It protects the discharge temperature. It is used to calculate the discharge superheat temperature.
TH6	Thermistor	It detects the low pressure saturation temperature to control the compressor frequency.
TH3	Thermistor (Pipe temperature/Defrost determination)	It is used to control LEV pulse in cooling mode. It is used to start the defrost mode in heating mode.
TH7	Thermistor (Detects the ambient air temperature)	It detects the ambient temperature to control outdoor fan and LEV pulse.
TH8	Thermistor (radiator plate temperature)	It detects the power transistor radiator plate temperature for protection of power transistor.
63HS	High pressure sensor	It detects the discharge pressure to control the compressor frequency and protects unit against damage by high pressure. It is used to calculate the sub cool. (Detects discharge pressure)
SC1	Sub cool of indoor unit 1	Heating mode:Sub cool
SC2	Sub cool of indoor unit 2	Heating mode:Sub cool
SC3	Sub cool of indoor unit 3	Heating mode:Sub cool
SC4	Sub cool of indoor unit 4	Heating mode:Sub cool
SC5	Sub cool of indoor unit 5	Heating mode:Sub cool
SC6	Sub cool of indoor unit 6	Heating mode:Sub cool
SC7	Sub cool of indoor unit 7	Heating mode:Sub cool
SC8	Sub cool of indoor unit 8	Heating mode:Sub cool
SCm1	Target sub cool of indoor unit 1	Heating mode:Target sub cool
SCm2	Target sub cool of indoor unit 2	Heating mode:Target sub cool
SCm3	Target sub cool of indoor unit 3	Heating mode:Target sub cool
SCm4	Target sub cool of indoor unit 4	Heating mode:Target sub cool
SCm5	Target sub cool of indoor unit 5	Heating mode:Target sub cool
SCm6	Target sub cool of indoor unit 6	Heating mode:Target sub cool
SCm7	Target sub cool of indoor unit 7	Heating mode:Target sub cool
SCm8	Target sub cool of indoor unit 8	Heating mode:Target sub cool
LEV1	LEV pulse of indoor unit 1	LEV pulse of indoor unit 1 LEV pulse control from the outdoor unit
LEV2	LEV pulse of indoor unit 2	LEV pulse of indoor unit 2 LEV pulse control from the outdoor unit
LEV3	LEV pulse of indoor unit 3	LEV pulse of indoor unit 3 LEV pulse control from the outdoor unit
LEV4	LEV pulse of indoor unit 4	LEV pulse of indoor unit 4 LEV pulse control from the outdoor unit
LEV5	LEV pulse of indoor unit 5	LEV pulse of indoor unit 5 LEV pulse control from the outdoor unit

		it
LEV6	LEV pulse of indoor unit 6	LEV pulse of indoor unit 6 LEV pulse control from the outdoor un it
LEV7	LEV pulse of indoor unit 7	LEV pulse of indoor unit 7 LEV pulse control from the outdoor un it
LEV8	LEV pulse of indoor unit 8	LEV pulse of indoor unit 8 LEV pulse control from the outdoor un it
INPUT CURRENT	INPUT CURRENT	Input current of outdoor unit.
COMP CURRENT	COMPRESSOR CURRENT	Compressor operating current of outdoor unit.

Operation Status Monitor Terminology

(PUMY-P125/140V/YHMBR3,
PUMY-P100/125/140YHMC-C, PUMY-SP100/125/140YHMC-SD,
PUMY-P100/125/140VHMC-S, PUMY-SP100/125/140VHMC-SR)

<Notes on monitoring the PUMY series units with the Maintenance Tool>

When monitoring the PUMY series of outdoor units with the Maintenance Tool, indeterminate values will appear as the sensor values for models without built-in sensors. See the manuals of the respective models for the presence or absence of sensors.

Mark	Official Name	Meaning
Operation mode		Operation mode
FAN	Fan steps	Out door unit fan steps
F/Hz	Compressor frequency	Compressor frequency
SC	Sub cool	Sub cool
SCm	Target sub cool	Target sub cool (cooling)
Pdm	Target high pressure	Target high pressure (heating)
ETm	Target evaporation temperature	Target evaporation temperature (cooling)
52C	electromagnetic contactor	52C output (inverter main circuit)
21S4	4-way valve	4-way valve
SV1(A)	Solenoid valve 1 output	The bypass of discharge gas (for pd back up)
SV1(B)	Solenoid valve 1 output	The bypass of discharge gas(for td back up)
SV1(C)	Solenoid valve 1 output	The bypass of discharge gas(for stop mode pressure equalization)
TH4	Thermistor (Detects discharge temperature)	It detects the discharge temperature to control the compressor frequency. It protects the discharge temperature. It is used to calculate the discharge superheat temperature.
TH6	Thermistor	It detects the low pressure saturation temperature to control the compressor frequency.
TH3	Thermistor (Pipe temperature/Defrost determination)	It is used to control LEV pulse in cooling mode. It is used to start the defrost mode in heating mode.
TH7	Thermistor (Detects the ambient air temperature)	It detects the ambient temperature to control outdoor fan and LEV pulse.
TH8	Thermistor (radiator plate temperature)	It detects the power transistor radiator plate temperature for protection of power transistor.
63HS	High pressure sensor	It detects the discharge pressure to control the compressor frequency and protects unit against damage by high pressure. It is used to calculate the sub cool. (Detects discharge pressure)
SC 1	Sub cool of indoor unit 1	Heating mode:Sub cool of indoor unit 1
SC 2	Sub cool of indoor unit 2	Heating mode:Sub cool of indoor unit 2
SC 3	Sub cool of indoor unit 3	Heating mode:Sub cool of indoor unit 3
SC 4	Sub cool of indoor unit 4	Heating mode:Sub cool of indoor unit 4
SC 5	Sub cool of indoor unit 5	Heating mode:Sub cool of indoor unit 5
SC 6	Sub cool of indoor unit 6	Heating mode:Sub cool of indoor unit 6
SC 7	Sub cool of indoor unit 7	Heating mode:Sub cool of indoor unit 7
SC 8	Sub cool of indoor unit 8	Heating mode:Sub cool of indoor unit 8
SC 9	Sub cool of indoor unit 9	Heating mode:Sub cool of indoor unit 9
SC10	Sub cool of indoor unit 10	Heating mode:Sub cool of indoor unit 10
SC11	Sub cool of indoor unit 11	Heating mode:Sub cool of indoor unit 11
SC12	Sub cool of indoor unit 12	Heating mode:Sub cool of indoor unit 12
SCm 1	Target sub cool of indoor unit 1	Heating mode:Target sub cool of indoor unit 1
SCm 2	Target sub cool of indoor unit 2	Heating mode:Target sub cool of indoor unit 2
SCm 3	Target sub cool of indoor unit 3	Heating mode:Target sub cool of indoor unit 3
SCm 4	Target sub cool of indoor unit 4	Heating mode:Target sub cool of indoor unit 4
SCm 5	Target sub cool of indoor unit 5	Heating mode:Target sub cool of indoor unit 5
SCm 6	Target sub cool of indoor unit 6	Heating mode:Target sub cool of indoor unit 6
SCm 7	Target sub cool of indoor unit 7	Heating mode:Target sub cool of indoor unit 7
SCm 8	Target sub cool of indoor unit 8	Heating mode:Target sub cool of indoor unit 8
SCm 9	Target sub cool of indoor unit 9	Heating mode:Target sub cool of indoor unit 9
SCm10	Target sub cool of indoor unit 10	Heating mode:Target sub cool of indoor unit 10
SCm11	Target sub cool of indoor unit 11	Heating mode:Target sub cool of indoor unit 11

	it 11	
SCm12	Target sub cool of indoor unit 12	Heating mode:Target sub cool of indoor unit 12
LEV 1	LEV pulse of indoor unit 1	LEV pulse of indoor unit 1 LEV pulse control from the outdoor unit
LEV 2	LEV pulse of indoor unit 2	LEV pulse of indoor unit 2 LEV pulse control from the outdoor unit
LEV 3	LEV pulse of indoor unit 3	LEV pulse of indoor unit 3 LEV pulse control from the outdoor unit
LEV 4	LEV pulse of indoor unit 4	LEV pulse of indoor unit 4 LEV pulse control from the outdoor unit
LEV 5	LEV pulse of indoor unit 5	LEV pulse of indoor unit 5 LEV pulse control from the outdoor unit
LEV 6	LEV pulse of indoor unit 6	LEV pulse of indoor unit 6 LEV pulse control from the outdoor unit
LEV 7	LEV pulse of indoor unit 7	LEV pulse of indoor unit 7 LEV pulse control from the outdoor unit
LEV 8	LEV pulse of indoor unit 8	LEV pulse of indoor unit 9 LEV pulse control from the outdoor unit
LEV 9	LEV pulse of indoor unit 9	LEV pulse of indoor unit 10 LEV pulse control from the outdoor unit
LEV10	LEV pulse of indoor unit 10	LEV pulse of indoor unit 11 LEV pulse control from the outdoor unit
LEV11	LEV pulse of indoor unit 11	LEV pulse of indoor unit 12 LEV pulse control from the outdoor unit
LEV12	LEV pulse of indoor unit 12	LEV pulse of indoor unit 13 LEV pulse control from the outdoor unit
INPUT CURRENT	INPUT CURRENT	Input current of outdoor unit.
COMP CURRENT	COMPRESSOR CURRENT	Compressor operating current of outdoor unit.
VDC	BUS BAR VOLTAGE(V)	Bus bar voltage of inverter circuit

Operation Status Monitor Terminology

(PUHZ-RPHA)**

Mark	Official Name	Meaning
[Selecting Info.]		
action	Operation ON/OFF	Operation running of unit
mode	Running mode	Running mode of unit
TO	Set temperature	Temperature set by remote controller
capacity save	Capacity save	Capacity save signal from system controller Unit: % Non receiving status: 100%

Mark	Official Name	Meaning
[Indoor Info.]		
TH1	Thermistor(room temperature)	Detects the room temperature, for deciding ON/OFF.
TH2	Thermistor (liquid pipe temperature)	Detects the liquid side temperature.
TH5	Thermistor (gas pipe temperature)	Detects the gas side temperature.

Mark	Official Name	Meaning
[Outdoor Info.]		
COMP	Ccmp. ON/OFF	Ccmp. ON/OFF (ON:running)
21S4	4-way valve	Switches the cooling/heating cycle (ON:Heating)
SV	Solenoid valve output	Solenoid valve output (ON:Action)
FAN	Fan output step	Fan output step
Hz	Compressor frequency	Compressor frequency
49C	Inner thermostat (compressor)	Inner thermostat (compressor) actuation state "closing": at the time of usual. "open": at the time of actuation.
63H	High pressure sensor	Detects the discharge pressure and then protects unit against damage by high pressure. "closing": at the time of usual. "open": at the time of actuation.
63L	Low pressure sensor	Detects the suction pressure and then, senses the refrigerant composition. "closing": at the time of usual. "open": at the time of actuation.
TH3	Thermistor	Detects the liquid pipe temperature
TH4	Thermistor	Detects discharge temperature
TH6	Thermistor	Detects saturated evaporation temperature
TH7	Thermistor	Detects the ambient air temperature
TH8	Thermistor	Detects radiator plate temperature
SHd	Discharge superheat	
SH	Superheat	
SC	Subcool	
LEV A	SC coil LEV opening	Adjusts refrigerant in the bypass pipe from liquid pipe in the outdoor unit in cooling mode.
LEV B	LEV opening B	

Operation Status Monitor Terminology (PUMY-P100V/YHMBR4)

<Notes on monitoring the PUMY series units with the Maintenance Tool>

When monitoring the PUMY series of outdoor units with the Maintenance Tool, indeterminate values will appear as the sensor values for models without built-in sensors. See the manuals of the respective models for the presence or absence of sensors.

Mark	Official Name	Meaning
Operation mode		Operation mode
F/Hz	Compressor frequency	Compressor frequency
FAN	Fan steps	Out door unit fan steps
VDC	BUS BAR VOLTAGE(V)	Bus bar voltage of inverter circuit
LEV_A	LEV-A pulse of outdoor unit (not implemented)	Command value of LEV-A pulse of outdoor unit (fixed to blank)
LEV_B	LEV-B pulse of outdoor unit (not implemented)	Command value of LEV-B pulse of outdoor unit (fixed to blank)
52C	electromagnetic contactor	52C output (inverter main circuit)
21S4	4-way valve	4-way valve
SV1(A)	Solenoid valve 1 output	The bypass of discharge gas (for pd back up)
SV1(B)	Solenoid valve 1 output	The bypass of discharge gas(for td back up)
SV1(C)	Solenoid valve 1 output	The bypass of discharge gas(for stop mode pressure equalization)
demand	A state of demand function via outdoor unit input	Input: 1 / No input: 0
TH4	Thermistor (Detects comp. surface temperature)	It detects the comp. surface temperature to control the compressor frequency. It protects the comp. surface temperature. It is used to calculate the discharge superheat temperature.
TH6	Thermistor	It detects the low pressure saturation temperature to control the compressor frequency.
TH3	Thermistor (Pipe temperature/Defrost determination)	It is used to control LEV pulse in cooling mode. It is used to start the defrost mode in heating mode.
TH7	Thermistor (Detects the ambient air temperature)	It detects the ambient temperature to control outdoor fan and LEV pulse.
TH8	Thermistor (radiator plate temperature)	It detects the power transistor radiator plate temperature for protection of power transistor.
63HS	High pressure sensor	It detects the discharge pressure to control the compressor frequency and protects unit against damage by high pressure. It is used to calculate the sub cool. (Detects discharge pressure)
63LS	Low pressure sensor (not implemented)	It detects the suction pressure to control LEV-B and LEVs of indoor units pulse. (fixed to 0.0)
TH2	Thermistor (not implemented) (HIC temperature)	It is used to control LEV-B pulse. (fixed to 0.0)
SC	Sub cool	Sub cool
SCm	Target sub cool	Target sub cool (cooling)
Pdm	Target high pressure	Target high pressure (heating)
ETm	Target evaporation temperature	Target evaporation temperature (cooling)
I(input)(A)	Input current	Input current of outdoor unit.
I(comp)(A)	Compressor current	Compressor operating current of outdoor unit.
SC 1	Sub cool of indoor unit 1	Heating mode:Sub cool of indoor unit 1
SC 2	Sub cool of indoor unit 2	Heating mode:Sub cool of indoor unit 2
SC 3	Sub cool of indoor unit 3	Heating mode:Sub cool of indoor unit 3
SC 4	Sub cool of indoor unit 4	Heating mode:Sub cool of indoor unit 4
SC 5	Sub cool of indoor unit 5	Heating mode:Sub cool of indoor unit 5
SC 6	Sub cool of indoor unit 6	Heating mode:Sub cool of indoor unit 6
SC 7	Sub cool of indoor unit 7	Heating mode:Sub cool of indoor unit 7
SC 8	Sub cool of indoor unit 8	Heating mode:Sub cool of indoor unit 8
SC 9	Sub cool of indoor unit 9	Heating mode:Sub cool of indoor unit 9
SC10	Sub cool of indoor unit 10	Heating mode:Sub cool of indoor unit 10
SC11	Sub cool of indoor unit 11	Heating mode:Sub cool of indoor unit 11
SC12	Sub cool of indoor unit 12	Heating mode:Sub cool of indoor unit 12
SCm 1	Target sub cool of indoor unit 1	Heating mode:Target sub cool of indoor unit 1
SCm 2	Target sub cool of indoor unit 2	Heating mode:Target sub cool of indoor unit 2
SCm 3	Target sub cool of indoor unit 3	Heating mode:Target sub cool of indoor unit 3
SCm 4	Target sub cool of indoor unit 4	Heating mode:Target sub cool of indoor unit 4
SCm 5	Target sub cool of indoor unit 5	Heating mode:Target sub cool of indoor unit 5

SCm 6	Target sub cool of indoor unit 6	Heating mode:Target sub cool of indoor unit 6
SCm 7	Target sub cool of indoor unit 7	Heating mode:Target sub cool of indoor unit 7
SCm 8	Target sub cool of indoor unit 8	Heating mode:Target sub cool of indoor unit 8
SCm 9	Target sub cool of indoor unit 9	Heating mode:Target sub cool of indoor unit 9
SCm10	Target sub cool of indoor unit 10	Heating mode:Target sub cool of indoor unit 10
SCm11	Target sub cool of indoor unit 11	Heating mode:Target sub cool of indoor unit 11
SCm12	Target sub cool of indoor unit 12	Heating mode:Target sub cool of indoor unit 12
LEV 1	LEV pulse of indoor unit 1	LEV pulse of indoor unit 1 LEV pulse control from the outdoor unit
LEV 2	LEV pulse of indoor unit 2	LEV pulse of indoor unit 2 LEV pulse control from the outdoor unit
LEV 3	LEV pulse of indoor unit 3	LEV pulse of indoor unit 3 LEV pulse control from the outdoor unit
LEV 4	LEV pulse of indoor unit 4	LEV pulse of indoor unit 4 LEV pulse control from the outdoor unit
LEV 5	LEV pulse of indoor unit 5	LEV pulse of indoor unit 5 LEV pulse control from the outdoor unit
LEV 6	LEV pulse of indoor unit 6	LEV pulse of indoor unit 6 LEV pulse control from the outdoor unit
LEV 7	LEV pulse of indoor unit 7	LEV pulse of indoor unit 7 LEV pulse control from the outdoor unit
LEV 8	LEV pulse of indoor unit 8	LEV pulse of indoor unit 8 LEV pulse control from the outdoor unit
LEV 9	LEV pulse of indoor unit 9	LEV pulse of indoor unit 9 LEV pulse control from the outdoor unit
LEV10	LEV pulse of indoor unit 10	LEV pulse of indoor unit 10 LEV pulse control from the outdoor unit
LEV11	LEV pulse of indoor unit 11	LEV pulse of indoor unit 11 LEV pulse control from the outdoor unit
LEV12	LEV pulse of indoor unit 12	LEV pulse of indoor unit 12 LEV pulse control from the outdoor unit

Operation Status Monitor Terminology (PUMY-P125/140V/YHMSR1)

<Notes on monitoring the PUMY series units with the Maintenance Tool>

When monitoring the PUMY series of outdoor units with the Maintenance Tool, indeterminate values will appear as the sensor values for models without built-in sensors. See the manuals of the respective models for the presence or absence of sensors.

Mark	Official Name	Meaning
Operation mode		Operation mode
F/Hz	Compressor frequency	Compressor frequency
FAN	Fan steps	Out door unit fan steps
VDC	BUS BAR VOLTAGE(V)	Bus bar voltage of inverter circuit
LEV_A	LEV-A pulse of outdoor unit (not implemented)	Command value of LEV-A pulse of outdoor unit (fixed to blank)
LEV_B	LEV-B pulse of outdoor unit (not implemented)	Command value of LEV-B pulse of outdoor unit (fixed to blank)
52C	electromagnetic contactor	52C output (inverter main circuit)
21S4	4-way valve	4-way valve
SV1(A)	Solenoid valve 1 output	The bypass of discharge gas (for pd back up)
SV1(B)	Solenoid valve 1 output	The bypass of discharge gas(for td back up)
SV1(C)	Solenoid valve 1 output	The bypass of discharge gas(for stop mode pressure equalization)
demand	A state of demand function via outdoor unit input	Input: 1 / No input: 0
TH4	Thermistor (Detects comp. surface temperature)	It detects the comp. surface temperature to control the compressor frequency. It protects the comp. surface temperature. It is used to calculate the discharge superheat temperature.
TH6	Thermistor	It detects the low pressure saturation temperature to control the compressor frequency.
TH3	Thermistor (Pipe temperature/Defrost determination)	It is used to control LEV pulse in cooling mode. It is used to start the defrost mode in heating mode.
TH7	Thermistor (Detects the ambient air temperature)	It detects the ambient temperature to control outdoor fan and LEV pulse.
TH8	Thermistor (radiator plate temperature)	It detects the power transistor radiator plate temperature for protection of power transistor.
63HS	High pressure sensor	It detects the discharge pressure to control the compressor frequency and protects unit against damage by high pressure. It is used to calculate the sub cool. (Detects discharge pressure)
63LS	Low pressure sensor (not implemented)	It detects the suction pressure to control LEV-B and LEVs of indoor units pulse. (fixed to 0.0)
TH2	Thermistor (not implemented) (HIC temperature)	It is used to control LEV-B pulse. (fixed to 0.0)
SC	Sub cool	Sub cool
SCm	Target sub cool	Target sub cool (cooling)
Pdm	Target high pressure	Target high pressure (heating)
ETm	Target evaporation temperature	Target evaporation temperature (cooling)
I(input)(A)	Input current	Input current of outdoor unit.
I(comp)(A)	Compressor current	Compressor operating current of outdoor unit.
SC 1	Sub cool of indoor unit 1	Heating mode:Sub cool of indoor unit 1
SC 2	Sub cool of indoor unit 2	Heating mode:Sub cool of indoor unit 2
SC 3	Sub cool of indoor unit 3	Heating mode:Sub cool of indoor unit 3
SC 4	Sub cool of indoor unit 4	Heating mode:Sub cool of indoor unit 4
SC 5	Sub cool of indoor unit 5	Heating mode:Sub cool of indoor unit 5
SC 6	Sub cool of indoor unit 6	Heating mode:Sub cool of indoor unit 6
SC 7	Sub cool of indoor unit 7	Heating mode:Sub cool of indoor unit 7
SC 8	Sub cool of indoor unit 8	Heating mode:Sub cool of indoor unit 8
SC 9	Sub cool of indoor unit 9	Heating mode:Sub cool of indoor unit 9
SC10	Sub cool of indoor unit 10	Heating mode:Sub cool of indoor unit 10
SC11	Sub cool of indoor unit 11	Heating mode:Sub cool of indoor unit 11
SC12	Sub cool of indoor unit 12	Heating mode:Sub cool of indoor unit 12
SCm 1	Target sub cool of indoor unit 1	Heating mode:Target sub cool of indoor unit 1
SCm 2	Target sub cool of indoor unit 2	Heating mode:Target sub cool of indoor unit 2
SCm 3	Target sub cool of indoor unit 3	Heating mode:Target sub cool of indoor unit 3
SCm 4	Target sub cool of indoor unit 4	Heating mode:Target sub cool of indoor unit 4
SCm 5	Target sub cool of indoor unit 5	Heating mode:Target sub cool of indoor unit 5

SCm 6	Target sub cool of indoor unit 6	Heating mode:Target sub cool of indoor unit 6
SCm 7	Target sub cool of indoor unit 7	Heating mode:Target sub cool of indoor unit 7
SCm 8	Target sub cool of indoor unit 8	Heating mode:Target sub cool of indoor unit 8
SCm 9	Target sub cool of indoor unit 9	Heating mode:Target sub cool of indoor unit 9
SCm10	Target sub cool of indoor unit 10	Heating mode:Target sub cool of indoor unit 10
SCm11	Target sub cool of indoor unit 11	Heating mode:Target sub cool of indoor unit 11
SCm12	Target sub cool of indoor unit 12	Heating mode:Target sub cool of indoor unit 12
LEV 1	LEV pulse of indoor unit 1	LEV pulse of indoor unit 1 LEV pulse control from the outdoor unit
LEV 2	LEV pulse of indoor unit 2	LEV pulse of indoor unit 2 LEV pulse control from the outdoor unit
LEV 3	LEV pulse of indoor unit 3	LEV pulse of indoor unit 3 LEV pulse control from the outdoor unit
LEV 4	LEV pulse of indoor unit 4	LEV pulse of indoor unit 4 LEV pulse control from the outdoor unit
LEV 5	LEV pulse of indoor unit 5	LEV pulse of indoor unit 5 LEV pulse control from the outdoor unit
LEV 6	LEV pulse of indoor unit 6	LEV pulse of indoor unit 6 LEV pulse control from the outdoor unit
LEV 7	LEV pulse of indoor unit 7	LEV pulse of indoor unit 7 LEV pulse control from the outdoor unit
LEV 8	LEV pulse of indoor unit 8	LEV pulse of indoor unit 8 LEV pulse control from the outdoor unit
LEV 9	LEV pulse of indoor unit 9	LEV pulse of indoor unit 9 LEV pulse control from the outdoor unit
LEV10	LEV pulse of indoor unit 10	LEV pulse of indoor unit 10 LEV pulse control from the outdoor unit
LEV11	LEV pulse of indoor unit 11	LEV pulse of indoor unit 11 LEV pulse control from the outdoor unit
LEV12	LEV pulse of indoor unit 12	LEV pulse of indoor unit 12 LEV pulse control from the outdoor unit

Operation Status Monitor Terminology

(PUMY-P112/125/140V/YKM(E),
PUMY-SP80V/YKMD-A(R1),
PUMY-CP100/125/140V/YKM,

PUMY-P112/125/140V/YKM-A,
PUMY-SP100/125/140V/YKM,
PUMY-P100/125/140NKM)

<Notes on monitoring the PUMY series units with the Maintenance Tool>

When monitoring the PUMY series of outdoor units with the Maintenance Tool, indeterminate values will appear as the sensor values for models without built-in sensors. See the manuals of the respective models for the presence or absence of sensors.

Mark	Official Name	Meaning
Operation mode		Operation mode
F/Hz	Compressor frequency	Compressor frequency
FAN	Fan steps	Out door unit fan steps
VDC	BUS BAR VOLTAGE(V)	Bus bar voltage of inverter circuit
LEV_A	LEV-A pulse of outdoor unit	Command value of LEV-A pulse of outdoor unit
LEV_B	LEV-B pulse of outdoor unit	Command value of LEV-B pulse of outdoor unit
52C	electromagnetic contactor	52C output (inverter main circuit)
21S4	4-way valve	4-way valve
SV1	Solenoid valve 1 output	Bypass valve for discharge gas
SV2	Solenoid valve 2 output	Switching valve for refrigerant circuit
SV3	Solenoid valve 3 output	Oil return valve
demand	A state of demand function via outdoor unit input	Input: 1 / No input: 0
TH4	Thermistor (Detects comp. surface temperature)	It detects the comp. surface temperature to control the compressor frequency. It protects the comp. surface temperature. It is used to calculate the discharge superheat temperature.
TH6	Thermistor	It detects the low pressure saturation temperature to control the compressor frequency.
TH3	Thermistor (Pipe temperature/Defrost determination)	It is used to control LEV pulse in cooling mode. It is used to start the defrost mode in heating mode.
TH7	Thermistor (Detects the ambient air temperature)	It detects the ambient temperature to control outdoor fan and LEV pulse.
TH8	Thermistor (radiator plate temperature)	It detects the power transistor radiator plate temperature for protection of power transistor.
63HS	High pressure sensor	It detects the discharge pressure to control the compressor frequency and protects unit against damage by high pressure. It is used to calculate the sub cool. (Detects discharge pressure)
63LS	Low pressure sensor	It detects the suction pressure to control LEV-B and LEVs of indoor units pulse.
TH2	Thermistor (HIC temperature)	It is used to control LEV-B pulse.
SC	Sub cool	Sub cool
SCm	Target sub cool	Target sub cool (cooling)
Pdm	Target high pressure	Target high pressure (heating)
ETm	Target evaporation temperature	Target evaporation temperature (cooling)
I(input)(A)	Input current	Input current of outdoor unit.
I(comp)(A)	Compressor current	Compressor operating current of outdoor unit.
SC 1	Sub cool of indoor unit 1	Heating mode:Sub cool of indoor unit 1
SC 2	Sub cool of indoor unit 2	Heating mode:Sub cool of indoor unit 2
SC 3	Sub cool of indoor unit 3	Heating mode:Sub cool of indoor unit 3
SC 4	Sub cool of indoor unit 4	Heating mode:Sub cool of indoor unit 4
SC 5	Sub cool of indoor unit 5	Heating mode:Sub cool of indoor unit 5
SC 6	Sub cool of indoor unit 6	Heating mode:Sub cool of indoor unit 6
SC 7	Sub cool of indoor unit 7	Heating mode:Sub cool of indoor unit 7
SC 8	Sub cool of indoor unit 8	Heating mode:Sub cool of indoor unit 8
SC 9	Sub cool of indoor unit 9	Heating mode:Sub cool of indoor unit 9
SC10	Sub cool of indoor unit 10	Heating mode:Sub cool of indoor unit 10
SC11	Sub cool of indoor unit 11	Heating mode:Sub cool of indoor unit 11
SC12	Sub cool of indoor unit 12	Heating mode:Sub cool of indoor unit 12
SCm 1	Target sub cool of indoor unit 1	Heating mode:Target sub cool of indoor unit 1
SCm 2	Target sub cool of indoor unit 2	Heating mode:Target sub cool of indoor unit 2
SCm 3	Target sub cool of indoor unit 3	Heating mode:Target sub cool of indoor unit 3
SCm 4	Target sub cool of indoor unit 4	Heating mode:Target sub cool of indoor unit 4
SCm 5	Target sub cool of indoor unit 5	Heating mode:Target sub cool of indoor unit 5

SCm 6	Target sub cool of indoor unit 6	Heating mode:Target sub cool of indoor unit 6
SCm 7	Target sub cool of indoor unit 7	Heating mode:Target sub cool of indoor unit 7
SCm 8	Target sub cool of indoor unit 8	Heating mode:Target sub cool of indoor unit 8
SCm 9	Target sub cool of indoor unit 9	Heating mode:Target sub cool of indoor unit 9
SCm10	Target sub cool of indoor unit 10	Heating mode:Target sub cool of indoor unit 10
SCm11	Target sub cool of indoor unit 11	Heating mode:Target sub cool of indoor unit 11
SCm12	Target sub cool of indoor unit 12	Heating mode:Target sub cool of indoor unit 12
LEV 1	LEV pulse of indoor unit 1	LEV pulse of indoor unit 1 LEV pulse control from the outdoor unit
LEV 2	LEV pulse of indoor unit 2	LEV pulse of indoor unit 2 LEV pulse control from the outdoor unit
LEV 3	LEV pulse of indoor unit 3	LEV pulse of indoor unit 3 LEV pulse control from the outdoor unit
LEV 4	LEV pulse of indoor unit 4	LEV pulse of indoor unit 4 LEV pulse control from the outdoor unit
LEV 5	LEV pulse of indoor unit 5	LEV pulse of indoor unit 5 LEV pulse control from the outdoor unit
LEV 6	LEV pulse of indoor unit 6	LEV pulse of indoor unit 6 LEV pulse control from the outdoor unit
LEV 7	LEV pulse of indoor unit 7	LEV pulse of indoor unit 7 LEV pulse control from the outdoor unit
LEV 8	LEV pulse of indoor unit 8	LEV pulse of indoor unit 8 LEV pulse control from the outdoor unit
LEV 9	LEV pulse of indoor unit 9	LEV pulse of indoor unit 9 LEV pulse control from the outdoor unit
LEV10	LEV pulse of indoor unit 10	LEV pulse of indoor unit 10 LEV pulse control from the outdoor unit
LEV11	LEV pulse of indoor unit 11	LEV pulse of indoor unit 11 LEV pulse control from the outdoor unit
LEV12	LEV pulse of indoor unit 12	LEV pulse of indoor unit 12 LEV pulse control from the outdoor unit

Operation Status Monitor Terminology

(PUMY-P200/250YKMC-C, PUMY-P200/250YKM1-CN, PUMY-SP200/250YKM1-SD)

<Notes on monitoring the PUMY series units with the Maintenance Tool>

When monitoring the PUMY series of outdoor units with the Maintenance Tool, indeterminate values will appear as the sensor values for models without built-in sensors. See the manuals of the respective models for the presence or absence of sensors.

Mark	Official Name	Meaning
Operation mode		Operation mode
F/Hz	Compressor frequency	Compressor frequency
FAN	Fan steps	Out door unit fan steps
VDC	BUS BAR VOLTAGE(V)	Bus bar voltage of inverter circuit
LEV_A	LEV-A pulse of outdoor unit	Command value of LEV-A pulse of outdoor unit (fixed to blank)
LEV_B	LEV-B pulse of outdoor unit	Command value of LEV-B pulse of outdoor unit (fixed to blank)
52C	electromagnetic contactor	52C output (inverter main circuit)
21S4	4-way valve	4-way valve
SV1	Solenoid valve 1 output	Bypass valve for discharge gas
SV2	Solenoid valve 2 output	Switching valve for refrigerant circuit
SV3	Solenoid valve 3 output	Oil return valve
demand	A state of demand function via outdoor unit input	Input: 1 / No input: 0
TH4	Thermistor (Detects comp. surface temperature)	It detects the comp. surface temperature to control the compressor frequency. It protects the comp. surface temperature. It is used to calculate the discharge superheat temperature.
TH6	Thermistor	It detects the low pressure saturation temperature to control the compressor frequency.
TH3	Thermistor (Pipe temperature/Defrost determination)	It is used to control LEV pulse in cooling mode. It is used to start the defrost mode in heating mode.
TH7	Thermistor (Detects the ambient air temperature)	It detects the ambient temperature to control outdoor fan and LEV pulse.
TH8	Thermistor (radiator plate temperature)	It detects the power transistor radiator plate temperature for protection of power transistor.
63HS	High pressure sensor	It detects the discharge pressure to control the compressor frequency and protects unit against damage by high pressure. It is used to calculate the sub cool. (Detects discharge pressure)
63LS	Low pressure sensor	It detects the suction pressure to control LEV-B and LEVs of indoor units pulse.
TH2	Thermistor (HIC temperature)	It is used to control LEV-B pulse.
SC	Sub cool	Sub cool
SCm	Target sub cool	Target sub cool (cooling)
Pdm	Target high pressure	Target high pressure (heating)
ETm	Target evaporation temperature	Target evaporation temperature (cooling)
I(input)(A)	Input current	Input current of outdoor unit.
I(comp)(A)	Compressor current	Compressor operating current of outdoor unit.
SC 1	Sub cool of indoor unit 1	Heating mode:Sub cool of indoor unit 1
SC 2	Sub cool of indoor unit 2	Heating mode:Sub cool of indoor unit 2
SC 3	Sub cool of indoor unit 3	Heating mode:Sub cool of indoor unit 3
SC 4	Sub cool of indoor unit 4	Heating mode:Sub cool of indoor unit 4
SC 5	Sub cool of indoor unit 5	Heating mode:Sub cool of indoor unit 5
SC 6	Sub cool of indoor unit 6	Heating mode:Sub cool of indoor unit 6
SC 7	Sub cool of indoor unit 7	Heating mode:Sub cool of indoor unit 7
SC 8	Sub cool of indoor unit 8	Heating mode:Sub cool of indoor unit 8
SC 9	Sub cool of indoor unit 9	Heating mode:Sub cool of indoor unit 9
SC10	Sub cool of indoor unit 10	Heating mode:Sub cool of indoor unit 10
SC11	Sub cool of indoor unit 11	Heating mode:Sub cool of indoor unit 11
SC12	Sub cool of indoor unit 12	Heating mode:Sub cool of indoor unit 12
SCm 1	Target sub cool of indoor unit 1	Heating mode:Target sub cool of indoor unit 1
SCm 2	Target sub cool of indoor unit 2	Heating mode:Target sub cool of indoor unit 2
SCm 3	Target sub cool of indoor unit 3	Heating mode:Target sub cool of indoor unit 3
SCm 4	Target sub cool of indoor unit 4	Heating mode:Target sub cool of indoor unit 4
SCm 5	Target sub cool of indoor unit 5	Heating mode:Target sub cool of indoor unit 5

SCm 6	Target sub cool of indoor unit 6	Heating mode:Target sub cool of indoor unit 6
SCm 7	Target sub cool of indoor unit 7	Heating mode:Target sub cool of indoor unit 7
SCm 8	Target sub cool of indoor unit 8	Heating mode:Target sub cool of indoor unit 8
SCm 9	Target sub cool of indoor unit 9	Heating mode:Target sub cool of indoor unit 9
SCm10	Target sub cool of indoor unit 10	Heating mode:Target sub cool of indoor unit 10
SCm11	Target sub cool of indoor unit 11	Heating mode:Target sub cool of indoor unit 11
SCm12	Target sub cool of indoor unit 12	Heating mode:Target sub cool of indoor unit 12
LEV 1	LEV pulse of indoor unit 1	LEV pulse of indoor unit 1 LEV pulse control from the outdoor unit
LEV 2	LEV pulse of indoor unit 2	LEV pulse of indoor unit 2 LEV pulse control from the outdoor unit
LEV 3	LEV pulse of indoor unit 3	LEV pulse of indoor unit 3 LEV pulse control from the outdoor unit
LEV 4	LEV pulse of indoor unit 4	LEV pulse of indoor unit 4 LEV pulse control from the outdoor unit
LEV 5	LEV pulse of indoor unit 5	LEV pulse of indoor unit 5 LEV pulse control from the outdoor unit
LEV 6	LEV pulse of indoor unit 6	LEV pulse of indoor unit 6 LEV pulse control from the outdoor unit
LEV 7	LEV pulse of indoor unit 7	LEV pulse of indoor unit 7 LEV pulse control from the outdoor unit
LEV 8	LEV pulse of indoor unit 8	LEV pulse of indoor unit 8 LEV pulse control from the outdoor unit
LEV 9	LEV pulse of indoor unit 9	LEV pulse of indoor unit 9 LEV pulse control from the outdoor unit
LEV10	LEV pulse of indoor unit 10	LEV pulse of indoor unit 10 LEV pulse control from the outdoor unit
LEV11	LEV pulse of indoor unit 11	LEV pulse of indoor unit 11 LEV pulse control from the outdoor unit
LEV12	LEV pulse of indoor unit 12	LEV pulse of indoor unit 12 LEV pulse control from the outdoor unit

Operation Status Monitor Terminology

(PUMY-P200YKM, PUMY-P175/200/225YKM, MXZ-8C200VAM-C, MXZ-8C200VAM2-CN1, PUMY-P200YKMD, PUMY-CP175/200/225YKM, MXZ-8C200VAM1-CT, MXZ-8C225/250XAM.TH-TW1)

<Notes on monitoring the PUMY series units with the Maintenance Tool>

When monitoring the PUMY series of outdoor units with the Maintenance Tool, indeterminate values will appear as the sensor values for models without built-in sensors. See the manuals of the respective models for the presence or absence of sensors.

Mark	Official Name	Meaning
Operation mode		Operation mode
F/Hz	Compressor frequency	Compressor frequency
FAN	Fan steps	Out door unit fan steps
VDC	BUS BAR VOLTAGE(V)	Bus bar voltage of inverter circuit
LEV_A	LEV-A pulse of outdoor unit	Command value of LEV-A pulse of outdoor unit
LEV_B	LEV-B pulse of outdoor unit	Command value of LEV-B pulse of outdoor unit
52C	electromagnetic contactor	52C output (inverter main circuit)
21S4	4-way valve	4-way valve
SV1	Solenoid valve 1 output	Bypass valve for discharge gas
SV2	Solenoid valve 2 output	Switching valve for refrigerant circuit
SV3	Solenoid valve 3 output	Oil return valve
demand	A state of demand function via outdoor unit input	Input: 1 / No input: 0
TH4	Thermistor (Detects comp. surface temperature)	It detects the comp. surface temperature to control the compressor frequency. It protects the comp. surface temperature. It is used to calculate the discharge superheat temperature.
TH6	Thermistor	It detects the low pressure saturation temperature to control the compressor frequency.
TH3	Thermistor (Pipe temperature/Defrost determination)	It is used to control LEV pulse in cooling mode. It is used to start the defrost mode in heating mode.
TH7	Thermistor (Detects the ambient air temperature)	It detects the ambient temperature to control outdoor fan and LEV pulse.
TH8	Thermistor (radiator plate temperature)	It detects the power transistor radiator plate temperature for protection of power transistor.
63HS	High pressure sensor	It detects the discharge pressure to control the compressor frequency and protects unit against damage by high pressure. It is used to calculate the sub cool. (Detects discharge pressure)
63LS	Low pressure sensor	It detects the suction pressure to control LEV-B and LEVs of indoor units pulse.
TH2	Thermistor (HIC temperature)	It is used to control LEV-B pulse.
SC	Sub cool	Sub cool
SCm	Target sub cool	Target sub cool (cooling)
Pdm	Target high pressure	Target high pressure (heating)
ETm	Target evaporation temperature	Target evaporation temperature (cooling)
I(input)(A)	Input current	Input current of outdoor unit.
I(comp)(A)	Compressor current	Compressor operating current of outdoor unit.
SC 1	Sub cool of indoor unit 1	Heating mode:Sub cool of indoor unit 1
SC 2	Sub cool of indoor unit 2	Heating mode:Sub cool of indoor unit 2
SC 3	Sub cool of indoor unit 3	Heating mode:Sub cool of indoor unit 3
SC 4	Sub cool of indoor unit 4	Heating mode:Sub cool of indoor unit 4
SC 5	Sub cool of indoor unit 5	Heating mode:Sub cool of indoor unit 5
SC 6	Sub cool of indoor unit 6	Heating mode:Sub cool of indoor unit 6
SC 7	Sub cool of indoor unit 7	Heating mode:Sub cool of indoor unit 7
SC 8	Sub cool of indoor unit 8	Heating mode:Sub cool of indoor unit 8
SC 9	Sub cool of indoor unit 9	Heating mode:Sub cool of indoor unit 9
SC10	Sub cool of indoor unit 10	Heating mode:Sub cool of indoor unit 10
SC11	Sub cool of indoor unit 11	Heating mode:Sub cool of indoor unit 11
SC12	Sub cool of indoor unit 12	Heating mode:Sub cool of indoor unit 12
SCm 1	Target sub cool of indoor unit 1	Heating mode:Target sub cool of indoor unit 1
SCm 2	Target sub cool of indoor unit 2	Heating mode:Target sub cool of indoor unit 2
SCm 3	Target sub cool of indoor unit 3	Heating mode:Target sub cool of indoor unit 3
SCm 4	Target sub cool of indoor unit 4	Heating mode:Target sub cool of indoor unit 4

SCm 5	Target sub cool of indoor unit 5	Heating mode:Target sub cool of indoor unit 5
SCm 6	Target sub cool of indoor unit 6	Heating mode:Target sub cool of indoor unit 6
SCm 7	Target sub cool of indoor unit 7	Heating mode:Target sub cool of indoor unit 7
SCm 8	Target sub cool of indoor unit 8	Heating mode:Target sub cool of indoor unit 8
SCm 9	Target sub cool of indoor unit 9	Heating mode:Target sub cool of indoor unit 9
SCm10	Target sub cool of indoor unit 10	Heating mode:Target sub cool of indoor unit 10
SCm11	Target sub cool of indoor unit 11	Heating mode:Target sub cool of indoor unit 11
SCm12	Target sub cool of indoor unit 12	Heating mode:Target sub cool of indoor unit 12
LEV 1	LEV pulse of indoor unit 1	LEV pulse of indoor unit 1 LEV pulse control from the outdoor unit
LEV 2	LEV pulse of indoor unit 2	LEV pulse of indoor unit 2 LEV pulse control from the outdoor unit
LEV 3	LEV pulse of indoor unit 3	LEV pulse of indoor unit 3 LEV pulse control from the outdoor unit
LEV 4	LEV pulse of indoor unit 4	LEV pulse of indoor unit 4 LEV pulse control from the outdoor unit
LEV 5	LEV pulse of indoor unit 5	LEV pulse of indoor unit 5 LEV pulse control from the outdoor unit
LEV 6	LEV pulse of indoor unit 6	LEV pulse of indoor unit 6 LEV pulse control from the outdoor unit
LEV 7	LEV pulse of indoor unit 7	LEV pulse of indoor unit 7 LEV pulse control from the outdoor unit
LEV 8	LEV pulse of indoor unit 8	LEV pulse of indoor unit 8 LEV pulse control from the outdoor unit
LEV 9	LEV pulse of indoor unit 9	LEV pulse of indoor unit 9 LEV pulse control from the outdoor unit
LEV10	LEV pulse of indoor unit 10	LEV pulse of indoor unit 10 LEV pulse control from the outdoor unit
LEV11	LEV pulse of indoor unit 11	LEV pulse of indoor unit 11 LEV pulse control from the outdoor unit
LEV12	LEV pulse of indoor unit 12	LEV pulse of indoor unit 12 LEV pulse control from the outdoor unit

Operation Status Monitor Terminology

(MXZ-8C140/160VAMD-A,

MXZ-6C53VAM-SG1,

MXZ-8C112/140/160VAMZ-C,

MXZ-6C112/8C140/8C160NAM)

MXZ-8C112/140/160VAMZ-C,

Mark	Official Name	Meaning
Operation mode		Operation mode
F/Hz	Compressor frequency	Compressor frequency
FAN	Fan steps	Out door unit fan steps
VDC	BUS BAR VOLTAGE(V)	Bus bar voltage of inverter circuit
LEV_A	LEV-A pulse of outdoor unit	Command value of LEV-A pulse of outdoor unit
LEV_B	LEV-B pulse of outdoor unit	Command value of LEV-B pulse of outdoor unit
52C	electromagnetic contactor	52C output (inverter main circuit)
21S4	4-way valve	4-way valve
SV1	Solenoid valve 1 output	Bypass valve for discharge gas
SV2	Solenoid valve 2 output	Switching valve for refrigerant circuit
SV3	Solenoid valve 3 output	Oil return valve
demand	A state of demand function via outdoor unit input	Input: 1 / No input: 0
TH4	Thermistor (Detects comp. surface temperature)	It detects the comp. surface temperature to control the compressor frequency. It protects the comp. surface temperature. It is used to calculate the discharge superheat temperature.
TH6	Thermistor	It detects the low pressure saturation temperature to control the compressor frequency.
TH3	Thermistor (Pipe temperature/Defrost determination)	It is used to control LEV pulse in cooling mode. It is used to start the defrost mode in heating mode.
TH7	Thermistor (Detects the ambient air temperature)	It detects the ambient temperature to control outdoor fan and LEV pulse.
TH8	Thermistor (radiator plate temperature)	It detects the power transistor radiator plate temperature for protection of power transistor.
63HS	High pressure sensor	It detects the discharge pressure to control the compressor frequency and protects unit against damage by high pressure. It is used to calculate the sub cool. (Detects discharge pressure)
63LS	Low pressure sensor	It detects the suction pressure to control LEV-B and LEV's of indoor units pulse.
TH2	Thermistor (HIC temperature)	It is used to control LEV-B pulse.
SC	Sub cool	Sub cool
SCm	Target sub cool	Target sub cool (cooling)
Pdm	Target high pressure	Target high pressure (heating)
ETm	Target evaporation temperature	Target evaporation temperature (cooling)
I(input)(A)	Input current	Input current of outdoor unit.
I(comp)(A)	Compressor current	Compressor operating current of outdoor unit.
SC 1	Sub cool of indoor unit 1	Heating mode:Sub cool of indoor unit 1
SC 2	Sub cool of indoor unit 2	Heating mode:Sub cool of indoor unit 2
SC 3	Sub cool of indoor unit 3	Heating mode:Sub cool of indoor unit 3
SC 4	Sub cool of indoor unit 4	Heating mode:Sub cool of indoor unit 4
SC 5	Sub cool of indoor unit 5	Heating mode:Sub cool of indoor unit 5
SC 6	Sub cool of indoor unit 6	Heating mode:Sub cool of indoor unit 6
SC 7	Sub cool of indoor unit 7	Heating mode:Sub cool of indoor unit 7
SC 8	Sub cool of indoor unit 8	Heating mode:Sub cool of indoor unit 8
SC 9	Sub cool of indoor unit 9	Heating mode:Sub cool of indoor unit 9
SC10	Sub cool of indoor unit 10	Heating mode:Sub cool of indoor unit 10
SC11	Sub cool of indoor unit 11	Heating mode:Sub cool of indoor unit 11
SC12	Sub cool of indoor unit 12	Heating mode:Sub cool of indoor unit 12
SCm 1	Target sub cool of indoor unit 1	Heating mode:Target sub cool of indoor unit 1
SCm 2	Target sub cool of indoor unit 2	Heating mode:Target sub cool of indoor unit 2
SCm 3	Target sub cool of indoor unit 3	Heating mode:Target sub cool of indoor unit 3
SCm 4	Target sub cool of indoor unit 4	Heating mode:Target sub cool of indoor unit 4
SCm 5	Target sub cool of indoor unit 5	Heating mode:Target sub cool of indoor unit 5
SCm 6	Target sub cool of indoor unit 6	Heating mode:Target sub cool of indoor unit 6
SCm 7	Target sub cool of indoor unit 7	Heating mode:Target sub cool of indoor unit 7

SCm 8	Target sub cool of indoor unit 8	Heating mode:Target sub cool of indoor unit 8
SCm 9	Target sub cool of indoor unit 9	Heating mode:Target sub cool of indoor unit 9
SCm10	Target sub cool of indoor unit 10	Heating mode:Target sub cool of indoor unit 10
SCm11	Target sub cool of indoor unit 11	Heating mode:Target sub cool of indoor unit 11
SCm12	Target sub cool of indoor unit 12	Heating mode:Target sub cool of indoor unit 12
LEV 1	LEV pulse of indoor unit 1	LEV pulse of indoor unit 1 LEV pulse control from the outdoor unit
LEV 2	LEV pulse of indoor unit 2	LEV pulse of indoor unit 2 LEV pulse control from the outdoor unit
LEV 3	LEV pulse of indoor unit 3	LEV pulse of indoor unit 3 LEV pulse control from the outdoor unit
LEV 4	LEV pulse of indoor unit 4	LEV pulse of indoor unit 4 LEV pulse control from the outdoor unit
LEV 5	LEV pulse of indoor unit 5	LEV pulse of indoor unit 5 LEV pulse control from the outdoor unit
LEV 6	LEV pulse of indoor unit 6	LEV pulse of indoor unit 6 LEV pulse control from the outdoor unit
LEV 7	LEV pulse of indoor unit 7	LEV pulse of indoor unit 7 LEV pulse control from the outdoor unit
LEV 8	LEV pulse of indoor unit 8	LEV pulse of indoor unit 8 LEV pulse control from the outdoor unit
LEV 9	LEV pulse of indoor unit 9	LEV pulse of indoor unit 9 LEV pulse control from the outdoor unit
LEV10	LEV pulse of indoor unit 10	LEV pulse of indoor unit 10 LEV pulse control from the outdoor unit
LEV11	LEV pulse of indoor unit 11	LEV pulse of indoor unit 11 LEV pulse control from the outdoor unit
LEV12	LEV pulse of indoor unit 12	LEV pulse of indoor unit 12 LEV pulse control from the outdoor unit

Operation Status Monitor Terminology

(PUMY-P250/300YBM, PUMY-SP250/300YBM-SD.TH,
MXZ-12C280/335YAM-CN1)

<Notes on monitoring the PUMY series units with the Maintenance Tool>

When monitoring the PUMY series of outdoor units with the Maintenance Tool, indeterminate values will appear as the sensor values for models without built-in sensors. See the manuals of the respective models for the presence or absence of sensors.

Mark	Official Name	Meaning
Operation mode		Operation mode
F/Hz	Compressor frequency	Compressor frequency
FAN	Fan steps	Out door unit fan steps
VDC	BUS BAR VOLTAGE(V)	Bus bar voltage of inverter circuit
LEV_A	LEV-A pulse of outdoor unit	Command value of LEV-A pulse of outdoor unit
LEV_B	LEV-B pulse of outdoor unit	Command value of LEV-B pulse of outdoor unit
52C	electromagnetic contactor	52C output (inverter main circuit)
21S4	4-way valve	4-way valve
SV1	Solenoid valve 1 output	Bypass valve for discharge gas
SV2	Solenoid valve 2 output	Switching valve for refrigerant circuit
SV3	Solenoid valve 3 output	Oil return valve
demand	A state of demand function via outdoor unit input	Input: 1 / No input: 0
TH4	Thermistor (Detects comp. surface temperature)	It detects the comp. surface temperature to control the compressor frequency. It protects the comp. surface temperature. It is used to calculate the discharge superheat temperature.
TH6	Thermistor	It detects the low pressure saturation temperature to control the compressor frequency.
TH3	Thermistor (Pipe temperature/Defrost determination)	It is used to control LEV pulse in cooling mode. It is used to start the defrost mode in heating mode.
TH7	Thermistor (Detects the ambient air temperature)	It detects the ambient temperature to control outdoor fan and LEV pulse.
TH8	Thermistor (radiator plate temperature)	It detects the power transistor radiator plate temperature for protection of power transistor.
63HS	High pressure sensor	It detects the discharge pressure to control the compressor frequency and protects unit against damage by high pressure. It is used to calculate the sub cool. (Detects discharge pressure)
63LS	Low pressure sensor	It detects the suction pressure to control LEV-B and LEVs of indoor units pulse.
TH2	Thermistor (HIC temperature)	It is used to control LEV-B pulse.
SC	Sub cool	Sub cool
SCm	Target sub cool	Target sub cool (cooling)
Pdm	Target high pressure	Target high pressure (heating)
ETm	Target evaporation temperature	Target evaporation temperature (cooling)
I(input)(A)	Input current	Input current of outdoor unit.
I(comp)(A)	Compressor current	Compressor operating current of outdoor unit.
SC 1	Sub cool of indoor unit 1	Heating mode:Sub cool of indoor unit 1
SC 2	Sub cool of indoor unit 2	Heating mode:Sub cool of indoor unit 2
SC 3	Sub cool of indoor unit 3	Heating mode:Sub cool of indoor unit 3
SC 4	Sub cool of indoor unit 4	Heating mode:Sub cool of indoor unit 4
SC 5	Sub cool of indoor unit 5	Heating mode:Sub cool of indoor unit 5
SC 6	Sub cool of indoor unit 6	Heating mode:Sub cool of indoor unit 6
SC 7	Sub cool of indoor unit 7	Heating mode:Sub cool of indoor unit 7
SC 8	Sub cool of indoor unit 8	Heating mode:Sub cool of indoor unit 8
SC 9	Sub cool of indoor unit 9	Heating mode:Sub cool of indoor unit 9
SC10	Sub cool of indoor unit 10	Heating mode:Sub cool of indoor unit 10
SC11	Sub cool of indoor unit 11	Heating mode:Sub cool of indoor unit 11
SC12	Sub cool of indoor unit 12	Heating mode:Sub cool of indoor unit 12
SC13	Sub cool of indoor unit 13	Heating mode:Sub cool of indoor unit 13
SC14	Sub cool of indoor unit 14	Heating mode:Sub cool of indoor unit 14
SC15	Sub cool of indoor unit 15	Heating mode:Sub cool of indoor unit 15
SC16	Sub cool of indoor unit 16	Heating mode:Sub cool of indoor unit 16
SC17	Sub cool of indoor unit 17	Heating mode:Sub cool of indoor unit 17
SC18	Sub cool of indoor unit 18	Heating mode:Sub cool of indoor unit 18
SC19	Sub cool of indoor unit 19	Heating mode:Sub cool of indoor unit 19
SC20	Sub cool of indoor unit 20	Heating mode:Sub cool of indoor unit 20
SC21	Sub cool of indoor unit 21	Heating mode:Sub cool of indoor unit 21
SC22	Sub cool of indoor unit 22	Heating mode:Sub cool of indoor unit 22
SC23	Sub cool of indoor unit 23	Heating mode:Sub cool of indoor unit 23

SC24	Sub cool of indoor unit 24	Heating mode:Sub cool of indoor unit 24
SC25	Sub cool of indoor unit 25	Heating mode:Sub cool of indoor unit 25
SC26	Sub cool of indoor unit 26	Heating mode:Sub cool of indoor unit 26
SC27	Sub cool of indoor unit 27	Heating mode:Sub cool of indoor unit 27
SC28	Sub cool of indoor unit 28	Heating mode:Sub cool of indoor unit 28
SC29	Sub cool of indoor unit 29	Heating mode:Sub cool of indoor unit 29
SC30	Sub cool of indoor unit 30	Heating mode:Sub cool of indoor unit 30
SCm 1	Target sub cool of indoor unit 1	Heating mode:Target sub cool of indoor unit 1
SCm 2	Target sub cool of indoor unit 2	Heating mode:Target sub cool of indoor unit 2
SCm 3	Target sub cool of indoor unit 3	Heating mode:Target sub cool of indoor unit 3
SCm 4	Target sub cool of indoor unit 4	Heating mode:Target sub cool of indoor unit 4
SCm 5	Target sub cool of indoor unit 5	Heating mode:Target sub cool of indoor unit 5
SCm 6	Target sub cool of indoor unit 6	Heating mode:Target sub cool of indoor unit 6
SCm 7	Target sub cool of indoor unit 7	Heating mode:Target sub cool of indoor unit 7
SCm 8	Target sub cool of indoor unit 8	Heating mode:Target sub cool of indoor unit 8
SCm 9	Target sub cool of indoor unit 9	Heating mode:Target sub cool of indoor unit 9
SCm10	Target sub cool of indoor unit 10	Heating mode:Target sub cool of indoor unit 10
SCm11	Target sub cool of indoor unit 11	Heating mode:Target sub cool of indoor unit 11
SCm12	Target sub cool of indoor unit 12	Heating mode:Target sub cool of indoor unit 12
SCm13	Target sub cool of indoor unit 13	Heating mode:Target sub cool of indoor unit 13
SCm14	Target sub cool of indoor unit 14	Heating mode:Target sub cool of indoor unit 14
SCm15	Target sub cool of indoor unit 15	Heating mode:Target sub cool of indoor unit 15
SCm16	Target sub cool of indoor unit 16	Heating mode:Target sub cool of indoor unit 16
SCm17	Target sub cool of indoor unit 17	Heating mode:Target sub cool of indoor unit 17
SCm18	Target sub cool of indoor unit 18	Heating mode:Target sub cool of indoor unit 18
SCm19	Target sub cool of indoor unit 19	Heating mode:Target sub cool of indoor unit 19
SCm20	Target sub cool of indoor unit 20	Heating mode:Target sub cool of indoor unit 20
SCm21	Target sub cool of indoor unit 21	Heating mode:Target sub cool of indoor unit 21
SCm22	Target sub cool of indoor unit 22	Heating mode:Target sub cool of indoor unit 22
SCm23	Target sub cool of indoor unit 23	Heating mode:Target sub cool of indoor unit 23
SCm24	Target sub cool of indoor unit 24	Heating mode:Target sub cool of indoor unit 24
SCm25	Target sub cool of indoor unit 25	Heating mode:Target sub cool of indoor unit 25
SCm26	Target sub cool of indoor unit 26	Heating mode:Target sub cool of indoor unit 26
SCm27	Target sub cool of indoor unit 27	Heating mode:Target sub cool of indoor unit 27
SCm28	Target sub cool of indoor unit 28	Heating mode:Target sub cool of indoor unit 28
SCm29	Target sub cool of indoor unit 29	Heating mode:Target sub cool of indoor unit 29
SCm30	Target sub cool of indoor unit 30	Heating mode:Target sub cool of indoor unit 30
LEV 1	LEV pulse of indoor unit 1	LEV pulse of indoor unit 1 LEV pulse control from the outdoor unit
LEV 2	LEV pulse of indoor unit 2	LEV pulse of indoor unit 2 LEV pulse control from the outdoor unit
LEV 3	LEV pulse of indoor unit 3	LEV pulse of indoor unit 3 LEV pulse control from the outdoor unit
LEV 4	LEV pulse of indoor unit 4	LEV pulse of indoor unit 4 LEV pulse control from the outdoor unit
LEV 5	LEV pulse of indoor unit 5	LEV pulse of indoor unit 5 LEV pulse control from the outdoor unit

Operation Status Monitor Terminology (PUHN-200/250YMF-B,YMC)

Mark	Official Name	Meaning
Control mode		Control mode for outdoor unit
Operation mode		Operation mode for outdoor unit
F3	Temporary compressor frequency of NO.3 COMP for calculation	Variable for control
AK2	Heat exchanger capacity (Constant capacity unit)	Variable which determine the size of outdoor heat exchanger
AL	Accumulator level	Liquid level in the accumulation (0: A little, 1: Medium, 2: Much(overcharge))
FAN2	Fan (not proportional to rotational frequency)	Fan capacity of outdoor unit(Fan on a constant capacity unit)
SCO	Sub-cool at heat exchanger	Variable for control
SCC	Sub-cool at SC coil exit	Variable for control
SHB	SC coil bypass exit super heat	Variable for control
LEV1	SC coil LEV opening	Adjusts refrigerant in the bypass pipe from liquid pipe in the outdoor unit in cooling mode.
LEV2	Liquid pipe LEV opening	Controls a flow of liquid refrigerant
21S4	4-way valve	Switches the cooling/heating cycle (0:Cooling, 1:Heating)
SV1	Solenoid valve output (Bypass between discharge pipe and suction pipe)	Returns oil from the oil separator
SV4	Solenoid valve output (Bypass between discharge pipe and suction pipe)	Protection of over down low pressure(for evaporates refrigerant in an accumulator)
SV5b	Solenoid valve output (Liquid pipe)	Controls a flow of liquid refrigerant
TH11	Thermistor (Detects discharge temperature)	Detects the discharge temperature for protection of compressor.
TH3	Thermistor (Detects lower liquid level in the accumulator)	Detects the liquid level in the accumulator
TH4	Thermistor (Detects upper liquid level in the accumulator)	Detects the liquid level in the accumulator
TH5	Thermistor (Detects the liquid pipe temperature)	Controls compressor frequency, controls defrosting and detects the liquid level in heating mode, detects the sub-cool at the heat exchanger exit in combination with 63 HS data, and controls LEV1.
TH6	Thermistor (Detects the ambient air temperature)	Detects the ambient temperature and then, controls the liquid level in the accumulator.
TH7(8,9)	Thermistor (Controls SC)	Controls LEV1 based on the temperature differences between TH6,7,8 and 9.
TH10a	Thermistor (Gas pipe temperature of heat exchanger)	Detects outlet temperature of heat exchanger in heating mode.
TH10b	Thermistor (balance pipe)	Detects temperature of balance pipe.
63LS	Low pressure sensor	Detects the suction pressure.

Operation Status Monitor Terminology (PUHN-P200/250YMF-B,YMC)

Mark	Official Name	Meaning
Control mode		Control mode for outdoor unit
Operation mode		Operation mode for outdoor unit
F3	Temporary compressor frequency of NO.3 COMP for calculation	Variable for control
AK2	Heat exchanger capacity (Constant capacity unit)	Variable which determine the size of outdoor heat exchanger
AL	Accumulator level	Liquid level in the accumulation(0: A little, 1: Medium, 2: Much(overcharge))
FAN2	Fan	Fan capacity of outdoor unit (Fan on a constant capacity unit) (not proportional to rotational frequency)
SCO	Sub-cool at heat exchanger	Variable for control
SCC	Sub-cool at SC coil exit	Variable for control
SHB	SC coil bypass exit super heat	Variable for control
LEV1	SC coil LEV opening	Adjusts refrigerant in the bypass pipe from liquid pipe in the outdoor unit in cooling mode.
LEV2	Liquid pipe LEV opening	Controls a flow of liquid refrigerant
21S4	4-way valve	Switches the cooling/heating cycle (0:Cooling, 1:Heating)
SV1	Solenoid valve output (Bypass between discharge pipe and suction pipe)	Returns oil from the oil separator
SV22	Solenoid valve output (Capacity control full load)	Switches the capacity control valve inside the compressor
SV32	Solenoid valve output (Capacity control unload)	Switches the capacity control valve inside the compressor
SV4	Solenoid valve output (Bypass between discharge pipe and suction pipe)	Protection of over down low pressure (for evaporates refrigerant in an accumulator)
SV5b	Solenoid valve output (Liquid pipe)	Controls a flow of liquid refrigerant
TH11	Thermistor (Detects discharge temperature)	Detects the discharge temperature for protection of compressor.
TH3	Thermistor (Detects lower liquid level in the accumulator)	Detects the liquid level in the accumulator
TH4	Thermistor (Detects upper liquid level in the accumulator)	Detects the liquid level in the accumulator
TH5	Thermistor (Detects the liquid pipe temperature)	Controls compressor frequency, controls defrosting and detects the liquid level in heating mode, detects the sub-cool at the heat exchanger exit in combination with 63 HS data, and controls LEV1.
TH6	Thermistor (Detects the ambient air temperature)	Detects the ambient temperature and then, controls the liquid level in the accumulator.
TH7(8,9)	Thermistor (Controls SC)	Controls LEV1 based on the temperature differences between TH 6,7,8 and 9.
TH10a	Thermistor (Gas pipe temperature of heat exchanger)	Detects outlet temperature of heat exchanger in heating mode.
TH10b	Thermistor (balance pipe)	Detects temperature of balance pipe.
63LS	Low pressure sensor	Detects the suction pressure and then, senses the refrigerant composition.

Operation Status Monitor Terminology (PUHN-200/250YMF-C)

Mark	Official Name	Meaning
Control mode		Control mode for outdoor unit
Operation mode		Operation mode for outdoor unit
F3	Temporary compressor frequency of NO.3 COMP for calculation	Variable for control
AK2	Heat exchanger capacity (Constant capacity unit)	Variable which determine the size of outdoor heat exchanger
AL	Accumulator level	Liquid level in the accumulation (0: A little, 1: Medium, 2: Much(overcharge))
FAN2	Fan	Fan capacity of outdoor unit(Fan on a constant capacity unit) (not proportional to rotational frequency)
SCO	Sub-cool at heat exchanger	Variable for control
SCC	Sub-cool at SC coil exit	Variable for control
SHB	SC coil bypass exit super heat	Variable for control
LEV	SC coil LEV opening	Adjusts refrigerant in the bypass pipe from liquid pipe in the outdoor unit in cooling mode.
LEV2	Liquid pipe LEV opening	Controls a flow of liquid refrigerant
21S4	4-way valve	Switches the cooling/heating cycle (0:Cooling, 1:Heating)
SV1	Solenoid valve output (Bypass between discharge pipe and suction pipe)	Returns oil from the oil separator
SV4	Solenoid valve output (Bypass between discharge pipe and suction pipe)	Protection of over down low pressure(for evaporates refrigerant in an accumulator)
SV5b	Solenoid valve output (Liquid pipe)	Controls a flow of liquid refrigerant
TH11	Thermistor (Detects discharge temperature)	Detects the discharge temperature for protection of compressor.
TH3	Thermistor (Detects lower liquid level in the accumulator)	Detects the liquid level in the accumulator
TH4	Thermistor (Detects upper liquid level in the accumulator)	Detects the liquid level in the accumulator
TH5	Thermistor (Detects the liquid pipe temperature)	Controls compressor frequency, controls defrosting and detects the liquid level in heating mode, detects the sub-cool at the heat exchanger exit in combination with 63 HS data, and controls LEV1.
TH6	Thermistor (Detects the ambient air temperature)	Detects the ambient temperature and then, controls the liquid level in the accumulator.
TH7(8,9)	Thermistor(Controls SC)	Controls LEV1 based on the temperature differences between TH 6,7,8 and 9.
TH10a	Thermistor (Gas pipe temperature of heat exchanger)	Detects outlet temperature of heat exchanger in heating mode.
TH10b	Thermistor(balance pipe)	Detects temperature of balance pipe.
63LS	Low pressure sensor	Detects the suction pressure.

Operation Status Monitor Terminology (PUHN-P200/250YMF-C)

Mark	Official Name	Meaning
Control mode		Control mode for outdoor unit
Operation mode		Operation mode for outdoor unit
F3	Temporary compressor frequency of NO.3 COMP for calculation	Variable for control
AK2	Heat exchanger capacity (Constant capacity unit)	Variable which determine the size of outdoor heat exchanger
AL	Accumulator level	Liquid level in the accumulation (0: A little, 1: Medium, 2: Much(overcharge))
FAN2	Fan	Fan capacity of outdoor unit(Fan on a constant capacity unit) (not proportional to rotational frequency)
SCO	Sub-cool at heat exchanger	Variable for control
SCC	Sub-cool at SC coil exit	Variable for control
SHB	SC coil bypass exit super heat	Variable for control
LEV1	SC coil LEV opening	Adjusts refrigerant in the bypass pipe from liquid pipe in the outdoor unit in cooling mode.
LEV2	Liquid pipe LEV opening	Controls a flow of liquid refrigerant
21S4	4-way valve	Switches the cooling/heating cycle (0:Cooling, 1:Heating)
SV1	Solenoid valve output (Bypass between discharge pipe and suction pipe)	Returns oil from the oil separator
SV22	Solenoid valve output (Capacity control full load)	Switches the capacity control valve inside the compressor
SV32	Solenoid valve output (Capacity control unload)	Switches the capacity control valve inside the compressor
SV4	Solenoid valve output (Bypass between discharge pipe and suction pipe)	Protection of over down low pressure(for evaporates refrigerant in an accumulator)
SV5b	Solenoid valve output (Liquid pipe)	Controls a flow of liquid refrigerant
TH11	Thermistor (Detects discharge temperature)	Detects the discharge temperature for protection of compressor.
TH3	Thermistor (Detects lower liquid level in the accumulator)	Detects the liquid level in the accumulator
TH4	Thermistor (Detects upper liquid level in the accumulator)	Detects the liquid level in the accumulator
TH5	Thermistor (Detects the liquid pipe temperature)	Controls compressor frequency, controls defrosting and detects the liquid level in heating mode, detects the sub-cool at the heat exchanger exit in combination with 63 HS data, and controls LEV1.
TH6	Thermistor (Detects the ambient air temperature)	Detects the ambient temperature and then, controls the liquid level in the accumulator.
TH7(8,9)	Thermistor(Controls SC)	Controls LEV1 based on the temperature differences between TH 6,7,8 and 9.
TH10a	Thermistor (Gas pipe temperature of heat exchanger)	Detects outlet temperature of heat exchanger in heating mode.
TH10b	Thermistor(balance pipe)	Detects temperature of balance pipe.
63LS	Low pressure sensor	Detects the suction pressure and then, senses the refrigerant composition.

Operation Status Monitor Terminology

(ECOV-EN75/110/150/185/225/260/300/335MVB, ECOV-EN75/110/150/185/225/260/300/335VB)

Mark	Official Name	Meaning
TH1	Discharge pipe temperature	Discharge pipe temperature of the compressor
TH2	Compressor shell oil temperature	Oil temperature of the compressor shell bottom
TH4	-	For Japan market model
TH5	-	For Japan market model
TH6	Outside air temperature	Temperature of outside air
TH7	Suction pipe temperature	Suction pipe temperature of the compressor
TH8	Liquid pipe temperature	Temperature of the liquid pipe
HPS	High-pressure	Use for controlling compressor, fan and high-pressure protection.
LPS	Low-pressure	Use for controlling compressor, fan and low-pressure protection.
Idc	Direct current(INV DC current)	Peak value of the DCCT detection
Vdc	Bus voltage(INV DC voltage)	DC bus voltage
Tc	Condensation temperature (Converted high-pressure saturation temperature)	Condensation temperature of unit module.
Te	Evaporation temperature (Converted low-pressure saturation temperature)	Evaporation temperature of unit module.
THHS	Inverter heatsink temperature	Temperature of the heatsink. For controlling the inverter cooling fan.
AL	Liquid refrigerant flooding level	Determine the liquid refrigerant flooding condition. 0: dry, 1: wet, 2: liquid refrigerant flooding
Qnow	-	For Japan market model
Qave	-	For Japan market model
Tave	-	For Japan market model
Tem0	-	For Japan market model
Tem1	-	For Japan market model
Tem1'	-	For Japan market model
Tem1Shift	-	For Japan market model
Tcm	Target condensation temperature	Target condensation temperature of unit module. When unit correspondencing, It doesn't show because the controlling use representative value.
Tem	Target evaporation temperature	Target evaporation temperature of unit module.
Delta-Tcm	Target condensation temperature difference	Difference between the target condensation temperature and actual temperature(Tcm-Tc)
Delta-Tem	Target evaporation temperature difference	Difference between the target evaporation temperature and actual temperature(Tem-Te)
L.Cut off	Low-pressure cutoff compressor OFF-threshold	Low-pressure cutoff compressor OFF-threshold Unit:Mpa
L.Cut on	Low-pressure cutoff compressor ON-threshold	Low-pressure cutoff compressor ON-threshold Unit:Mpa
lead-in speed	Compressor suction speed	Rate of the low-pressure change of compressor Unit:Mpa/10s
Discharge-SH	Compressor discharge superheat	Discharge superheat of the compressor (TH1-Tc)
Esc	Instantaneous value of the subcool coil temperature efficiency	-
EscA	Average value of the subcool coil temperature efficiency	-
S-TH6	Representative outside air temperature	Representative outside air temperature of the overall unit
S-HPS	Representative high-pressure	Representative high-pressure of the overall unit Unit:Mpa
S-LPS	Representative low-pressure	Representative low-pressure of the overall unit Unit:Mpa
S-Coff	Overall Low-pressure cut-off value	Representative low-pressure cutoff compressor OFF-threshold of the overall unit Unit:Mpa
S-Con	Overall Low-pressure cut-on value	Representative low-pressure cutoff compressor ON-threshold of the overall unit Unit:Mpa
S-Tc	Representative condensation temperature	Representative value of the actual condensation temperature of the overall unit
S-Te	Representative evaporation	Representative value of the actual evaporation temperature of the overall

	temperature	unit
S-Tcm	Representative target condensation temperature	Representative value of the setting condensation temperature of the overall unit
S-Tem	Representative target evaporation temperature	Representative value of the setting evaporation temperature of the overall unit
S-Delta-Tcm	Representative target condensation temperature difference	S-Tcm - S-Tc
S-Delta-Tem	Representative target evaporation temperature difference	S-Tem - S-Te
S-Esc	Representative instantaneous value of the subcool coil temperature efficiency	Minimum value of the instantaneous value of the subcool coil temperature efficiency of the overall unit
S-EscA	Representative average value of the subcool coil temperature efficiency	Minimum value of the average value of the subcool coil temperature efficiency of the overall unit
Rst	Alarm reset input(X2)	Error alarm reset input.
ShiftM	-	For Japan market model
63H	63H	Show the high-pressure switch status. 1: ON, 0: OFF
63L	63L	Show the low-pressure switch (field-supplied) status. 1: ON, 0: OFF
X31	Operation input (X31)	Show the contact input status of the auxiliary relay <X31>. 1: ON, 0: OFF
SW2	Unit module operation SW (SW21, SW2, SW23)	Show the contact input status of the unit module operation switch. 1: ON, 0: OFF
SW4	Operation at fixed compressor frequency SW(SW4)	Show the contact input status of the switch <Normal-Fixed frequency>. 1: ON(Fixed frequency), 0: OFF(Normal)
X1	Operation SW(X11)	Show the contact input status of the operation switch (auxiliary relay <X11>). 1: ON, 0: OFF
CN63	CN63PW input	-
TYP1	TYPE1	-
TYP2	TYPE2	-
TYP4	TYPE4	-
TYP5	TYPE5	-
TYP6	TYPE6	-
Iu	Compressor U-phase current value	Inverter output current value(U-phase)
Iw	Compressor W-phase current value	Inverter output current value(W-phase)
Vunb	Limit of unbalance of power supply voltage	Show the state of the unbalance limiting control of power supply voltage. (1: Under control, 0: Nomal)
FAN-Ver	Fan inverter S/W version	Software version of the fan inverter
Ctrl mode	Control mode	Outdoor unit control mode
Ope mode	Operation mode	Outdoor unit operation mode
Fm	Target frequency of the compressor (unit module value) (Hz)	Target frequency of the compressor.
FAN(AK%)	Heat exchanger capacity (Fan output)	Variable of the motor rotation speed of the condenser fan (%)
Rpter	Repeater	Permit(1) /Prohibit (0) the communication with the centralized control system.
M-Supply	M-net power supply	Power supply to the indoor unit system. (M-net power supply)
f0	Current operating frequency of the compressor (Hz)	Current operating frequency of the compressor
S-Fm(Hz)	Target frequency of the compressor (overall value)(Hz) (only OC)	Target frequency of the compressor of overall unit.
X101	Auxiliary relay<X101> status	Used for the bypass solenoid valve output (the primary-side power-supply voltage). 1: ON, 0: OFF
X102	Auxiliary relay<X102> status	For Japan market model
X103	Auxiliary relay<X103> status	Used for the crankcase heater output (the primary-side power-supply voltage). 1: ON, 0: OFF
X104	Auxiliary relay<X104> status	Used for the solenoid valve <injection> output (the primary-side

		power-supply voltage). 1: ON, 0: OFF
X105	Auxiliary relay<X105> status	Used for the high/low pressure bypass solenoid valve output (the primary-side power-supply voltage). 1: ON, 0: OFF
X106	Auxiliary relay<X106> status	The solenoid valve <oil return> output (21Q1~3) (the primary-side power-supply voltage). 1: ON, 0: OFF
X107	Auxiliary relay<X107> status	Used for the output of the operating status of the compressor (auxiliary relay<X61> drive) (the primary-side power-supply voltage). 1: ON, 0: OFF
X108	Auxiliary relay<X108> status	Used for 52F output (the primary-side power-supply voltage). 1: ON, 0: OFF
X109	Auxiliary relay<X109> status	-
X110	Auxiliary relay<X110> status	-
X111	Auxiliary relay<X111> status	Used for the unit operation signal output (auxiliary relay<X4>drive) (the primary-side power-supply voltage). 1: ON, 0: OFF
X112	Auxiliary relay<X112> status	Used for the error alarm signal output (auxiliary relay<X5>drive) (the primary-side power-supply voltage). 1: ON, 0: OFF
X172	Auxiliary relay<X172> status	Used for the 72C drive source output (the primary-side power-supply voltage). 1: ON, 0: OFF
72C	Output of 72C for export	Used for the 72C drive source output (DC12V power-supply). 1: ON, 0: OFF
Err	Error output	-
COMP	Compressor ON/OFF output	-
LEV	LEV output value	LEV output value of the linear expansion valve<injection>. 0~480 pulse
SW1~4	DipSW1~4 input	Show the DipSW status. 1: ON, 0: OFF
Hc1	-	For Japan market model
Hc2	-	For Japan market model
Hc3		For Japan market model

Operation Status Monitor Terminology (ECOV-X15/37/55VA)

Mark	Official Name	Meaning
TH1	Discharge pipe temperature	Discharge pipe temperature of the compressor
TH2	Compressor oil temperature	Oil temperature of the compressor shell bottom
TH4	Gascooler outlet pipe temperature	Temperature of the gascooler outlet pipe
TH5	Heat exchanger outlet pipe temperature	Temperature of the heat exchanger outlet pipe
TH6	Outside air temperature	Temperature of outside air
TH7	Suction pipe temperature	Suction pipe temperature of the compressor
TH8	Liquid pipe temperature	Temperature of the liquid pipe
TH9	Oil pipe temperature	Temperature of the oil pipe
HPS1	High-pressure1	Use for controlling compressor, fan and high-pressure protection.
HPS2	High-pressure2	Use for controlling compressor, fan and high-pressure protection.
MPS	Middle-pressure	Use for controlling compressor, fan and middle-pressure protection.
LPS	Low-pressure	Use for controlling compressor, fan and low-pressure protection.
Vdc	Bus voltage(INV DC voltage)	DC bus voltage
Iac	Input current(INV AC current)	AC input current
Tc	Condensation temperature (Converted high-pressure saturation temperature)	Condensation temperature of unit module.
Te	Evaporation temperature (Converted low-pressure saturation temperature)	Evaporation temperature of unit module.
THHS	Inverter heatsink temperature	Temperature of the heatsink. For controlling the inverter cooling fan.
AL	Liquid refrigerant flooding level	Determine the liquid refrigerant flooding condition. 0: dry, 1: wet, 2: liquid refrigerant flooding
Tem0	Target evaporation temperature setting value	Target evaporation temperature setting value
Tcm	Target condensation temperature	Target condensation temperature of unit module. When unit correspondencing, it doesn't show because the controlling use representative value.
Tem	Target evaporation temperature	Target evaporation temperature of unit module.
Coff	Low-pressure cut-off value	Low-pressure cutoff compressor OFF-threshold
Con	Low-pressure cut-on value	Low-pressure cutoff compressor ON-threshold
S-Tc	Representative condensation temperature	Representative value of the actual condensation temperature of the overall unit
S-Te	Representative evaporation temperature	Representative value of the actual evaporation temperature of the overall unit
S-Tcm	Representative target condensation temperature	Representative value of the target condensation temperature of the overall unit
S-Tem	Representative target evaporation temperature	Representative value of the target evaporation temperature of the overall unit
Rst	Alarm reset input(X2)	Error alarm reset input.
63H	63H	Show the high-pressure switch status. 1: ON, 0: OFF
63L	63L	Show the low-pressure switch (field-supplied) status. 1: ON, 0: OFF
X3	Operation input(X31)	Show the contact input status of the auxiliary relay <X31>. 1: ON, 0: OFF
X1	Operation SW(X11)	Show the contact input status of the operation switch (auxiliary relay <X11>).
TYP1	-	-
TYP2	-	-
TYP4	-	-
TYP5	-	-
TYP6	-	-
Iu	Compressor U-phase current value	Inverter output current value(U-phase)
Iw	Compressor W-phase current value	Inverter output current value(W-phase)
Vunb	Limit of unbalance of power supply voltage	Show the state of the unbalance limiting control of power supply voltage. 1: Under control, 0: Nomal
Ctrl mode	Control mode	Outdoor unit control mode
Ope mode	Operation mode	Outdoor unit operation mode

Fm	Target frequency of the compressor(unit module value) (Hz)	Target frequency of the compressor
FAN(AK%)	Heat exchanger capacity (Fan output)	Variable of the motor rotation speed of the condenser fan (%)
Rpter	Repeater	Permit(1) /Prohibit (0) the M-net communication with the centralized control system.
M-Supply	M-net power supply	Power supply to the indoor unit system. (M-net power supply)
f0	Current operating frequency of the compressor (Hz)	Current operating frequency of the compressor
S-Fm(Hz)	Target frequency of the compressor(overall unit)(Hz)	Target frequency of the compressor of the overall unit
X101	Auxiliary relay<X101> status	Show the output status of the auxiliary relay <X101>. 1: ON, 0: OFF
X102	Auxiliary relay<X102> status	Show the output status of the auxiliary relay <X102>. 1: ON, 0: OFF
X103	Auxiliary relay<X103> status	Show the output status of the auxiliary relay <X103>. 1: ON, 0: OFF
X104	Auxiliary relay<X104> status	Show the output status of the auxiliary relay <X104>. 1: ON, 0: OFF
X105	Auxiliary relay<X105> status	Show the output status of the auxiliary relay <X105>. 1: ON, 0: OFF
X107	Auxiliary relay<X107> status	Show the output status of the auxiliary relay <X107>. 1: ON, 0: OFF
X111	Auxiliary relay<X111> status	Show the output status of the auxiliary relay <X111>. 1: ON, 0: OFF
X112	Auxiliary relay<X112> status	Show the output status of the auxiliary relay <X112>. 1: ON, 0: OFF
X113	Auxiliary relay<X113> status	Show the output status of the auxiliary relay <X113>. 1: ON, 0: OFF
13V-3	Fan1 auxiliary relay<X10> status	Show the output status of the auxiliary relay <X10> of fan1. 1: ON, 0: OFF
13V-4	Fan2 auxiliary relay<X10> status	Show the output status of the auxiliary relay <X10> of fan2. 1: ON, 0: OFF
72C	Output of 72C	Used for the 72C drive source output. 1: ON, 0: OFF
LEV1~LEV4	LEV output value	LEV output value
Nm	Target fan rotation speed	Target rotation speed of fan
avgNj1	Fan actual rotation speed1	Actual rotation speed of fan1
avgNj2	Fan actual rotation speed2	Actual rotation speed of fan2
Vsp1	Fan output voltage 1	Output voltage of fan1
Vsp2	Fan output voltage 2	Output voltage of fan2
SW1~4	DipSW1~4 input	Show the DipSW status. 1: ON, 0: OFF

Operation Status Monitor Terminology (LMAP02/03/04)

Mark	Official Name	Meaning
nviOnOff_n	input binding	Binding information of an operation input (0:No binding 1:Binding)
nvoOnOff_n	output binding	Binding information of an operation output (0:No binding 1:Binding)
IC CONNECT	IC connection information	State of connected indoor system (0:Nothing 1:Connected)
SW1-1~10	SW1 setting value	Standard function setting (0:OFF setting 1:ON setting)
SW2-1~6	SW2 setting value	Service function setting (0:OFF setting 1:ON setting)
SW3-1~6	SW3 setting value	Special function 1 setting (0:OFF setting 1:ON setting)
SW4~8	SW4~8 setting value	Special function 2 setting (0:OFF setting 1:ON setting)
SWU1~2	SWU1~2 setting value	Address of Air-conditioner (SWU1:1 position SWU2:10 position)
FLAG	Control flag	State of control flag (0:Set 1:Reset) (M:M-NET flag LON:LON flag)
ERROR	Error flag	State of error flag (0:Normal 1:Abnormality) (M:M-NET flag LON:LON flag)
PWR.FLR	Detection of power failure	Input of power failure detection (0:Normal 1:power failure)
NCRESET	Detection of NC's reset	Input of NC reset (0:Normal 1:Reset)
UPLINK	Detection of the uplink	Input of uplink (0:Normal 1:Detection)
CN02-2~3	Function state detection	Input of detection (0:Normal 1:Detection)
Rcv St VI	Received input data	LON receiving information on operation (St :State VI :Value)
Snd St VI	Transmitted output data	LON transmitted information on an operation state (St :State VI :Value)
StartHrtBt	nci information	Start time of automatic update(second unit)
StartOutTm	nci information	Start time when output changes(second unit)
AnalogWidth	nci information	Analog change width(- C unit)
MinOutTm	nci information	Minimum transmitting secured time(second unit)
SndHrtBt_1	nci information	Send heartbeat No.1(second unit)
SndHrtBt_2	nci information	Send heartbeat No.2(second unit)
SndHrtBt_3	nci information	Send heartbeat No.3(second unit)
InitStartTm	nci information	Initial output start time(second unit)
InitOutTm_1	nci information	Transmitting secured time No.1(second unit)
InitOutTm_2	nci information	Transmitting secured time No.2(second unit)
RevHrtBT_1	nci information	Receiving heartbeat setting No.1(second unit)
RevHrtBT_2	nci information	Receiving heartbeat setting No.2(second unit)
PollFetch	nci information	Pole fetch setting(HEX value)
Time_1	nci information	Time No.1(second unit)
Time_2	nci information	Time No.2(second unit)
Set_1	nci information	Setting No.1(HEX value)
Set_2	nci information	Setting No.2(HEX value)
Dual set point mode	Set point mode information	Set point mode of connected indoor system (0*:single set point mode 1:dual set point mode) * including disconnected indoor system

Operation Status Monitor Terminology (DOAS)

Mark	Official Name	Meaning
TH1	Thermistor(supply air temperature)	Detects the supply air temperature.
TO	Set temperature	Set value of supply air temperature.
ON/OFF	Operation ON/OFF	Operation running of DOAS
Mode	Running mode	Running mode of DOAS
Status	Operating condition	Operation status of DOAS
IC.S	Operation control	Operation signal

Operation Status Monitor Terminology

(FU : Fresh Master)

Mark	Official Name	Meaning								
Qj	Capacity code	Capacity Code - Model Number List <table border="1"> <thead> <tr> <th>Capacity Code</th> <th>Model Number</th> </tr> </thead> <tbody> <tr> <td>6</td> <td>P500</td> </tr> <tr> <td>10</td> <td>P800</td> </tr> <tr> <td>13</td> <td>P1000</td> </tr> </tbody> </table>	Capacity Code	Model Number	6	P500	10	P800	13	P1000
Capacity Code	Model Number									
6	P500									
10	P800									
13	P1000									
TH1	Thermistor(outside temperature):Detects intake temperature									
TH2	Thermistor (Liquid pipe temperature)	Detects liquid pipe temperature								
TH3	Thermistor (Gas pipe temperature)	Detects gas pipe temperature								
TH4	Thermistor(Room temperature)	Detects intake temperature								
SH/SC	Super heat/ Sub cool	In heating mode: Subcool/ In cooling mode :Superheat								
Li	LEV opening pulse	LEV opening pulse.								
TO	Target temperature	In heating mode--- Set point of Dip-SW3,4,5 In cooling mode--- Average target temperature of connected IC Other---- No meaning(IC mode whichever connected Target temperature)								
Save		Capacity save signal from system controller Unit: % Non-receiving status: 100%								
Mode	Operation mode	Operation mode								
Status	Running mode	Running mode								
Dam.	Damper status	Damper position (Lossnay/Bypass)								
Sign	Operation control of indoor unit	Operation status of indoor unit								

Operation Status Monitor Terminology (LC:Lossnay)

Mark	Official Name	Meaning																																
G_No	Group Number	Group Number Group number is the number given by Centralized Controller. Lossnays which have the same group number are in the same group.																																
OA temp.	Thermistor(outdoor air temperature)	Detects outdoor air temperature																																
RA temp.	Thermistor(Room air temperature)	Detects room air temperature																																
SA temp.	Thermistor(Supply air temperature)	Detects supply air temperature																																
OA Humidity	OA humidity	Detects outdoor air relative humidity																																
CO2 concentration	CO2 concentration	Detects CO2 concentration(ppm)																																
SA Setting(IU)	SA fan speed ordered from interlocked IC	SA fan speed ordered from interlocked IC and AHU (Stopping/Low (Extra Low)/Hi(Extra Hi)) To define fan speed [m3/h]																																
EA Setting(IU)	EA fan speed ordered from interlocked IC	EA fan speed ordered from interlocked IC and AHU (Stopping/Low (Extra Low)/Hi(Extra Hi)) To define fan speed [m3/h]																																
SA Setting(RC)	SA fan speed ordered from RC	SA fan speed ordered from RC (Stopping/Low (Extra Low)/Hi(Extra Hi)/Auto)																																
EA Setting(RC)	EA fan speed ordered from RC	EA fan speed ordered from RC (Stopping/Low (Extra Low)/Hi(Extra Hi)/Auto)																																
SA Operation	Supply fan status	Supply fan status (Stopping/Extra Low/Low/Hi/Extra Hi)																																
EA Operation	Exhaust fan status	Exhaust fan status (Stopping/Extra Low/Low/Hi/Extra Hi)																																
TO	Target temperature	Average target temperature of connected IC when ventilation mode is automatic mode																																
O/F	Operation ON/OFF	Operating status (Stopping/Operating/Interlocked operation/Delayed operation/Error)																																
Ventilation mode 1	Ventilation mode 1	Ventilation mode 1 (Ordinary/Night purge/24hr operation)																																
Ventilation mode 2	Ventilation mode 2	<table border="1"> <thead> <tr> <th>Mode</th> <th>Meaning</th> </tr> </thead> <tbody> <tr> <td>Ordinary</td> <td>Ordinary operating</td> </tr> <tr> <td>Intermittent stopping</td> <td>SA fan is stopping to avoid condensation in Lossnay cores</td> </tr> <tr> <td>Stopping under defrosting operation</td> <td>SA fan stopping because connected IC is defrosting operation</td> </tr> <tr> <td>All device OFF</td> <td>Stopping because all device OFF signal is given by SC</td> </tr> <tr> <td>Power air supply/exhaust</td> <td>Power air supply/exhaust operating</td> </tr> <tr> <td>Night purge</td> <td>Night purge operating</td> </tr> <tr> <td>Anti-freezing operation</td> <td>SA fan is stopping for anti-freezing in Lossnay cores</td> </tr> <tr> <td>Delayed operation</td> <td>Delayed operating (Maximum 30 minutes)</td> </tr> <tr> <td>Drying humidifier</td> <td>SA fan is operating to dry humidifiers</td> </tr> <tr> <td>Humidifying preparation</td> <td>SA fan is stopping to fill humidifiers with water</td> </tr> <tr> <td>High humidity intermittent operation</td> <td>SA fan is stopping to avoid condensation in Lossnay cores</td> </tr> <tr> <td>Heater cool down</td> <td>Heater cool down operation</td> </tr> <tr> <td>Ordinary</td> <td>Ordinary operating</td> </tr> <tr> <td>Intermittent stopping</td> <td>SA fan is stopping to avoid condensation in Lossnay cores</td> </tr> <tr> <td>Stopping under defrosting operation</td> <td>SA fan stopping because connected IC is defrosting operation</td> </tr> </tbody> </table>	Mode	Meaning	Ordinary	Ordinary operating	Intermittent stopping	SA fan is stopping to avoid condensation in Lossnay cores	Stopping under defrosting operation	SA fan stopping because connected IC is defrosting operation	All device OFF	Stopping because all device OFF signal is given by SC	Power air supply/exhaust	Power air supply/exhaust operating	Night purge	Night purge operating	Anti-freezing operation	SA fan is stopping for anti-freezing in Lossnay cores	Delayed operation	Delayed operating (Maximum 30 minutes)	Drying humidifier	SA fan is operating to dry humidifiers	Humidifying preparation	SA fan is stopping to fill humidifiers with water	High humidity intermittent operation	SA fan is stopping to avoid condensation in Lossnay cores	Heater cool down	Heater cool down operation	Ordinary	Ordinary operating	Intermittent stopping	SA fan is stopping to avoid condensation in Lossnay cores	Stopping under defrosting operation	SA fan stopping because connected IC is defrosting operation
Mode	Meaning																																	
Ordinary	Ordinary operating																																	
Intermittent stopping	SA fan is stopping to avoid condensation in Lossnay cores																																	
Stopping under defrosting operation	SA fan stopping because connected IC is defrosting operation																																	
All device OFF	Stopping because all device OFF signal is given by SC																																	
Power air supply/exhaust	Power air supply/exhaust operating																																	
Night purge	Night purge operating																																	
Anti-freezing operation	SA fan is stopping for anti-freezing in Lossnay cores																																	
Delayed operation	Delayed operating (Maximum 30 minutes)																																	
Drying humidifier	SA fan is operating to dry humidifiers																																	
Humidifying preparation	SA fan is stopping to fill humidifiers with water																																	
High humidity intermittent operation	SA fan is stopping to avoid condensation in Lossnay cores																																	
Heater cool down	Heater cool down operation																																	
Ordinary	Ordinary operating																																	
Intermittent stopping	SA fan is stopping to avoid condensation in Lossnay cores																																	
Stopping under defrosting operation	SA fan stopping because connected IC is defrosting operation																																	
Humidifying	Humidifier ordered	Humidifier ordered from RC(ON/OFF/Auto)																																
Humidifier valve	Humidifier status	Operation of Solenoid Valve (ON/OFF)																																
Ventilation	Damper ordered	Damper ordered from RC(Lossnay/Bypass/Auro)																																
Damper	Damper status	Damper status (Lossnay/Bypass)																																
SW002	Setting of dip-switch 2	Setting of dip-switch 2 (Refer to Lossnay Technical Manual and Installation Instruction for more information)																																
SW005	Setting of dip-switch 5	Setting of dip-switch 5 (Refer to Lossnay Technical Manual and Installation Instruction for more information)																																
SW006	Setting of dip-switch 6	Setting of dip-switch 6 (Refer to Lossnay Technical Manual and Installation Instruction for more information)																																

		more information)
SW007	Setting of dip-switch 7	Setting of dip-switch 7 (Refer to Lossnay Technical Manual and Installation Instruction for more information)
Monitor Output	Monitor output of TM3	Monitor outoput status for TM3-7,8,9 (ON-1,OFF-0)
Actual RPM SA1	Actual RPM SA1	Actual RPM SA1 (DC Motor only)
Motor PWM SA1	Motor PWM SA1	Motor PWM SA1 (DC Motor only)
Actual RPM EA1	Actual RPM EA1	Actual RPM EA1 (DC Motor only)
Motor PWM EA1	Motor PWM EA1	Motor PWM EA1 (DC Motor only)
Actual RPM SA2	Actual RPM SA2	Actual RPM SA2 (DC Motor only)
Motor PWM SA2	Motor PWM SA2	Motor PWM SA2 (DC Motor only)
Actual RPM EA2	Actual RPM EA2	Actual RPM EA2 (DC Motor only)
Motor PWM EA2	Motor PWM EA2	Motor PWM EA2 (DC Motor only)

Operation Status Monitor Terminology

(PWFY-P100/200VM-E-AU, PWFY-P100/140/200VM-E1-AU, PWFY-P100/140/200VM-E2-AU, PWFY-EP100VM-E1-AU, PWFY-EP100VM-E2-AU, PWFY-P36/72NMU-E-AU)

Mark	Official Name	Meaning
Ctrl Mode	Control Mode	Water HEX Unit control mode
Ope Mode	Operation Mode	Water HEX Unit operation mode
O/F	Operation ON/OFF	Operation running of Water HEX Unit
I/O	water temp.sensor position	water inlet temperature / water outlet temperature
AU S	Operation control of the outdoor unit	Operation signal of transmitting from Water HEX Unit to outdoor unit.
State	Operating condition	Operation status of Water HEX Unit
SV1	Solenoid valve	Bypass between gas pipe and liquid pipe
DEMAND	Control point demand	Input stop signal of compressor. (ON:effective, OFF:ineffective)
LEV1W	LEV1W opening pulse	Water Hex Unit LEV1W opening pulse.
TH22	Thermistor	Detects the liquid side temperature of Water HEX Unit for frost prevention and SH/SC control.
TH23	Thermistor	Detects the gas side temperature of Water HEX Unit for control sensor error and SH control.
TH6	Thermistor	water inlet temperature
TH8	Thermistor	water outlet temperature
To	Set temperature	Temperature set by remote controller
SC	Subcool	Subcool
SH	Superheat	Superheat

Operation Status Monitor Terminology

(PWFY-P100VM-E-BU, PWFY-P100VM-E1-BU, PWFY-P36NMU-E-BU)

Mark	Official Name	Meaning
Ctrl Mode	Control Mode	Booster Unit control mode
Ope Mode	Operation Mode	Booster Unit operation mode
O/F	Operation ON/OFF	Operation running of Booster Unit
I/O	water temp.sensor position	water inlet temperature / water outlet temperature
BU S	Operation control of the outdoor Unit	Operation signal of transmitting from Booster Unit to outdoor unit.
State	Operating condition	Operation status of Booster Unit
F	Temporary compressor frequency for calculation	Variable for control
DEMAND	Control point demand	Input stop signal of compressor. (ON:effective, OFF:ineffective)
LEV1W	LEV1W opening pulse	Booster Unit LEV1W opening pulse.
LEV2W	LEV2W opening pulse	Booster Unit LEV2W opening pulse.
TH11	Thermistor	Discharge temperature
TH22	Thermistor	Detects the liquid side temperature of Booster Unit for frost prevention and SH/SC control.
TH13	Thermistor	evaporator outlet temperature
TH6	Thermistor	water inlet temperature
TH8	Thermistor	water outlet temperature
THHS	Thermistor	Heat sink temperature
63HSW	Pressure sensor	High pressure
63LSW	Pressure sensor	Low pressure
To	Set temperature	Temperature set by remote controller
Vdc	COMP bus voltage	COMP bus voltage [V]
Iu	current effective value	current effective value [A]

Operation Status Monitor Terminology (CAHV-P500YA-HPB,CAHV-P500YB-HPB)

Mark	Official Name	Meaning
Ver	Software Version	Program ROM
Operation		Operation input source
Snow		RC→Remote control , SW→Switch

Input

Mark	Official Name	Meaning
On/Off Level		ON→Run , OFF→Stop
Water temp Ctrl		IN→Inlet water temperature emperature control OUT→Outlet water temperature based control
Main Water temp Ctrl		ON→External water temperature sensor OFF→Builtin sensor on the unit
Fan Mode		ON→Coercion , OFF→Ordinary
Hot Water		ON→Hot water , OFF→Heating
Heating Eco		ON→Heating Eco , OFF→Heating
Anti Freeze		ON→Anti Freeze , OFF→Off
COP/Capacity		ON→COP Priority , OFF→Capacity Priority
Multi Ctrl		ON→Multiple Ctrl , OFF→Individual control
Temp setting		ON→Effective , OFF→Invalid
On/Off setting		ON→Enable schedule setting OFF→Disable schedule setting

Status

Mark	Official Name	Meaning
On/Off Ctrl		Run/Stop
Fan Mode		ON→Coercion , OFF→Ordinary
Mode		Heating/Heating Eco/Hot Water/Anti Freeze
Defrost Mode		Other/Wait/Limit/On
Demand		ON→Control demand
Schedule		ON→Control schedule
Restart Lim		ON→Control restart
Remain (min)		Restart (minute)
Pre err (cnt)		Error count
Err code		Error content (M-NET code)
line		Refrigerant line 1,2,3
Total (hr)		Total hour

Mark	Official Name	Meaning
TH1	Thermistor	Discharge Ref temperature 1
TH2	Thermistor	Suction Ref temperature 1
TH3	Thermistor	Shell Ref temperature 1
TH4	Thermistor	Air hex Ref temperature 1
TH5	Thermistor	Discharge Ref temperature 2
TH6	Thermistor	Suction Ref temperature 2
TH7	Thermistor	Shell Ref temperature 2
TH8	Thermistor	Air hex Ref temperature 2
TH9	Thermistor	Outdoor temperature 1
TH10	Thermistor	Water Inlet temperature 1
TH11	Thermistor	Water Outlet temperature 1
TH12	Thermistor	Water Inlet temperature 2
TH13	Thermistor	Water Outlet temperature 2

TH14	Thermistor	Representative water temperature 1
TH15	Thermistor	Representative water temperature 2
TH16	Thermistor	Outdoor temperature 2
63H1		High pressure switch
HP1	Pressure sensor	High pressure sensor
LP1	Pressure sensor	Low pressure sensor
Iu		Phase-U current of compressor [A]
Iw		Phase-W current of compressor [A]
Idc		DC trunk line current [A]
Vdc		COMP bus voltage [V]
Ts		Target water temperature
Twi		Current inlet water temperature
Two		Current outlet water temperature
Twg	Main water temperature	TH14 or TH15 temperature which is selected
Tout	Main outdoor temperature	4-20mA2 or IT temperature which is selected
THHS	Thermistor	IGBT temperature
4/20IN1	4-20mA1	External analog input for Target water temp (4-20mA)
4/20IN2	4-20mA2	External analog input for Outdoor temp (4-20mA2)
0-10IN	0-10V/2-10V	External analog input for Target water temp (0-10V)
1-5IN	1-5V	External analog input for Target water temp (1-5V)
0-10out		
LEV1		LEV1 pulse
LEV2		LEV2 pulse at HIC circuit
COMP1		operating frequency in main circuit
COMP2		operating frequency in sub circuit
FAN		Outdoor unit fan output [%]
SHs		Target superheat value at the suction pipe to compressor
SH		difference from suction gas temp to saturated gas temp
Dtime		Defrosting time ban
Dtemp		Defrost start temperature
THc10		Water Inlet temperature compensation TH10
THc11		Water Outlet temperature compensation TH11
THc12		Water Inlet temperature compensation TH12
THc13		Water Outlet temperature compensation TH13
THc14		Representative water temperature compensation TH14
THc15		Representative water temperature compensation TH15

Schedule

Mark	Official Name	Meaning
Time		Current Time
Demand	Peak-demand control	Start time - End time
On/Off1	Scheduled operation 1	Operation start time 1 - Operation end time 1
On/Off2	Scheduled operation 2	Operation start time 2 - Operation end time 2
On/Off3	Scheduled operation 3	Operation start time 3 - Operation end time 3
Temp chg	Temperature change	Time 1 , Time 2
Set temp		Water temp. setting A,B,C
Thr-diff		Thermo differential 1,2
Main water temp	Control Sensor select(at Target Setting temp)	TH14 or TH15 temperature which is selected
Main water temp (2)	Control Sensor select(at Target Setting temp)	TH14 or TH15 temperature which is selected
Main water temp (3)	Control Sensor select(at Target Setting temp)	TH14 or TH15 temperature which is selected
L-noise (%)		Capacity low noise (%)

Demand (%)		Maximum capacity demand (%)
------------	--	-----------------------------

Operation Status Monitor Terminology (CRHV-P600YA-HPB)

Mark	Official Name	Meaning
Ver	Software Version	Program ROM

Input

Mark	Official Name	Meaning
Water temp Ctrl	-	IN→Inlet water temperature emperature control OUT→Outlet water temperature based control
Main Water temp Ctrl	-	ON→External water temperature sensor OFF→Builtin sensor on the unit
Multi Ctrl	-	ON→Multiple Ctrl , OFF→Individual control
Temp setting	-	ON→Effective , OFF→Invalid
On/Off setting	-	ON→Enable schedule setting

Status

Mark	Official Name	Meaning
On/Off Ctrl	-	Run/Stop
Demand	-	ON→Control demand
Restart Lim	-	ON→Control restart
Remain (min)	-	Restart (minute)
Pre err (cnt)	-	Error count
Err code	-	Error content (M-NET code)
Total (hr)	-	Total hour
Mode	-	Heating/Heating Eco/Hot Water/Anti Freeze
Schedule	-	ON→Control schedule

Schedule

Mark	Official Name	Meaning
Time	-	Current Time
Thr-diff1	-	Thermo differential 1
Thr-diff2	-	Thermo differential 2
Demand (max%)	-	Maximum capacity demand [%]
Demand	Peak-demand control	Start time - End time
On/Off1	Scheduled operation 1	Operation start time 1 - Operation end time 1
On/Off2	Scheduled operation 2	Operation start time 2 - Operation end time 2
On/Off3	Scheduled operation 3	Operation start time 3 - Operation end time 3
Temp chg1	-	Temperature change1
Temp chg2	-	Temperature change2
Setting temp1	-	Water temp. setting A
Setting temp2	-	Water temp. setting B
Setting temp3	-	Water temp. setting C
Main water temp1	Control Sensor select(at Target Setting temp)	TH15 or TH16 temperature which is selected
Main water temp2	Control Sensor select(at Target Setting temp)	TH15 or TH16 temperature which is selected
Main water temp3	Control Sensor select(at Target Setting temp)	TH15 or TH16 temperature which is selected

Input(CN142)

Mark	Official Name	Meaning
A1	RUN	Run/Stop
A3	Mode Change2	Heating Eco/Heating
B3	Pump Interlock	Normal/Error
C3	-	-
C4	Demand	ON/OFF
C5	Anti Freeze	ON/OFF
C6	Capacity	Capacity priority / Cop priority
D3	-	-
D4	Mode Change1	Hot water/Heating
D6	Flow Switch	Normal/Error

Output

Mark	Official Name	Meaning
X01	MAIN BOX=- SUB BOX=	MAIN BOX=Solenoid valve(Main injection circuit) SUB BOX=Solenoid valve(Injection circuit)
X02	MAIN BOX=- SUB BOX=	MAIN BOX=Crankcase heater(for heating the compressor) SUB BOX=Crankcase heater(for heating the compressor)
X03	MAIN BOX= SUB BOX=	MAIN BOX=Cooling Fan 1-1 SUB BOX=Cooling Fan 2-1
X04	MAIN BOX=- SUB BOX=	MAIN BOX=Pump operation command output (Hot water) SUB BOX=-
X05	MAIN BOX=- SUB BOX=	MAIN BOX=Pump operation command output (Heat source) SUB BOX=Cooling Fan 2-2
X06	MAIN BOX=- SUB BOX=-	MAIN BOX=Error display output SUB BOX=-
X07	MAIN BOX=- SUB BOX=-	MAIN BOX=Operation display output SUB BOX=-
X08	MAIN BOX=- SUB BOX=-	MAIN BOX=Emergency signal A(for extra heater) SUB BOX=-
X09	MAIN BOX=- SUB BOX=-	MAIN BOX=Three way valve SUB BOX=-

12Voutput

Mark	Official Name	Meaning
72C	-	-
52C	-	Electromagnetic relay(Inverter main circuit)

Unit condition Unit1 to Unit16

Mark	Official Name	Meaning
TH1	Thermistor	Discharge Ref temp. 1
TH2	Thermistor	Suction Ref temp. 1
TH3	Thermistor	Shell Ref temp. 1
TH4	Thermistor	Heat exchanger wall temp. 1
TH5	Thermistor	Discharge Ref temp. 2
TH6	Thermistor	Suction Ref temp. 2
TH7	Thermistor	Shell Ref temp. 2
TH8	Thermistor	Heat exchanger wall temp. 2
TH9	Thermistor	Outdoor temp. 1
TH11	Thermistor	Water inlet temp. 1
TH12	Thermistor	Water outlet temp. 1
TH13	Thermistor	Heat source inlet temp. 1
TH14	Thermistor	Heat source outlet temp. 1
TH15	Thermistor	External Water sensor. 1
TH16	Thermistor	External Water sensor. 2
TH17	Thermistor	Hot Water inlet temp. 2
TH18	Thermistor	Hot Water outlet temp. 2
TH20	Thermistor	Heat source inlet temp. 2
THc11	-	Hot Water Inlet temperature compensation 1 TH11
THc12	-	Hot Water Outlet temperature compensation 1 TH12
THc15	-	Representative water temperature compensation TH15
THc16	-	Representative water temperature compensation TH16
THc17	-	Hot Water Inlet temperature compensation 2 TH17
THc18	-	Hot Water Outlet temperature compensation 2 TH18
63H1	-	High pressure switch
HP	63HS	High pressure sensor
LP	63LS	Low pressure sensor
Vdc	-	COMP bus voltage [V]
Iu	-	Phase-U current of compressor [A]
Iw	-	Phase-W current of compressor [A]
Ts	-	Target water temperature
Twi	-	Current inlet hot water temperature
Two	-	Current outlet hot water temperature
Twg	Main water temperature	TH15 or TH16 temperature which is selected
Tout	Main outdoor temperature	4-20mA2 or IT temperature which is selected
SHs	-	Target superheat value at the suction pipe to compressor
SHt	-	-
SHb	-	-
THHS	Thermistor	IGBT temperature

LEV1	-	Electronic expansion valve(Main/Sub circuit)
LEV2	-	-
LEV3	-	Electronic expansion valve(Main/Sub injection circuit)
COMP1(Hz)	-	Operating frequency in main circuit [Hz]
COMP2(Hz)	-	Operating frequency in sub circuit [Hz]
4-20mA1	-	External analog input for Target water temp (4-20mA1)
0-10V	-	External analog input for Target water temp (0-10V/2-10V)
1-5V	-	External analog input for Target water temp (1-5V)
4-20mA2	-	External analog input for Outdoor temp (4-20mA2)

Operation Status Monitor Terminology

QAHV-N560YA-HPB, QAHV-N560YA-KR, QAHV-N136TAU-HPB

Status

Mark	Official Name	Meaning
On/Off Ctrl	On/Off Control	
System err	System error	
Demand		
Fan mode		ON : Forced The fan will remain in operation after the compressor has stopped (including when the operation status is "STOP"). OFF : Normal The fan will stop when the compressor stops.
Lnoise	Low noise mode	Operation using the set capacity as an upper limit
Lnoise(%)	Low noise capacity	Setting value used during Low noise mode.
Hot water	Hot water storage mode	
HeatingUp	Heatingup mode	
Demand(%)	Demand capacity	Setting value used during Demand control.
SWU3	SWU3	Rotary switch on control board
Pump	Pump output	Percentage of pump output (current value / maximum value) for water flow Rate control
Fan	Fan frequency	
LEVA		Command value of LEVA pulse of unit
LEVC		Command value of LEVC pulse of unit
pump2 Out	Pump output(secondary circuit)	Percentage of pump output (current value / maximum value) for water flow Rate control(secondary circuit)
Time		
Demand str	Demand start time	
Demand end	Demand end time	
Demand drv	On/Off Demand	
RestartLim	Compressor restart limit	
Remain	Time to compressor restart	
Pre err	Pre err cnt	
Err code		
63H1	High pressure switch	
TH1	Compressor Discharge Refrigerant temperature	
TH2	Compressor Suction Refrigerant temperature	
TH3	Gascooler Refrigerant temperature	
TH4	Air hex(Heat exchange) inlet Refrigerant temperature	
TH5	Air hex(Heat exchange) outlet Refrigerant temperature	
TH9	Outdoor temperature	
TH11	Water outlet temperature	
TH12	Water inlet temperature	
TH14	Shell Refrigerant temperature	
THHS	Heat sink temperature	
TH15	External water sensor.1	
TH16	External water sensor.2	
TH17	External water sensor.3	
TH15p	External water sensor.4(For 6 sensor system only)	
TH16p	External water sensor.5(For 6 sensor system only)	
TH17p	External water sensor.6(For 6 sensor system only)	
TH18	External Water sensor (secondary circuit)	
TH19	no use	
HP1	High pressure senser [Mpa]	
LP1	Low pressure senser [Mpa]	
F	Compressor frequency	
OpeMode		-(stop)/Defrost/HeatingUp/HotWaterStrage
Tej1	Defrost start air coil refrigerant temperature	Items for product developers.
Teios1	Target compressor suction superheat(LEV control)	Items for product developers.
Teio1	Current compressor suction superheat	Items for product developers.
Tdgos		Items for product developers. (Discharge refrigerant tempeRateure gas cooler outlet refrigerant temperature) target value

Iu	U-Phase current effective value[A]	
Iw	W-Phase current effective value[A]	
I _{dc}	DC trunk line current [A]	
V _{dc}	Bus voltage [V]	
V _{p-p}	No use	
MVW1		Flow control valve MV 1 Valve opening
4-20mA/1-5V/0-10V/2-10V IN	Analog input 4-20mA/0-10V/1-5V/2-10V	External analog input for Target water temperature
ThermoOffTemp	Thermo off temperature	Thermooff temperature (= Target tempeRateure of tank)
CurrentHWTemp	Current hotwater temperature	Control target outlet temperature
TargetOutletTemp	Outlet hot water temperature (boiling temperature)	
TargetOutletTemp2	Outlet hot water temperature (boiling temperature) (secondary circuit)	
TargetFlowRate1	Target flow Rate	
TargetFlowRate2	Target flow Rate (secondary circuit)	
FlowRate1(L/m)	Flow sensor.1	flow rate (L per minutes)
FlowRate2(L/m)	Flow sensor (secondary circuit)	flow rate (L per minutes)
FlowRate3(L/m)	no use	

Operation Status Monitor Terminology (EACV-P900YA,EAHV-P900YA,EAHV-P900YA-H)

Mark	Official Name	Meaning
Ver	Software Version	Program ROM

Input

Mark	Official Name	Meaning
Water temp Ctrl	-	IN→Inlet water temperature emperature control OUT→Outlet water temperature based control
Main Water temp Ctrl	-	ON→External water temperature sensor OFF→Built-in sensor on the unit
Multi Ctrl	-	ON→Multiple Ctrl , OFF→Individual control
Temp setting	-	ON→Effective , OFF→Invalid
On/Off setting	-	ON→Enable schedule setting

Status

Mark	Official Name	Meaning
On/Off Ctrl	-	Run/Stop
Fan Mode	-	ON→Control fan
Defrost Mode	-	Other/Wait/Limit/On
Demand	-	ON→Control demand
Restart Lim	-	ON→Control restart
Remain (min)	-	Restart (minute)
Pre err (cnt)	-	Error count
Err code	-	Error content (M-NET code)
Detail	-	Detail error code
Total (hr)	-	Total hour
Mode	-	Heating/Heating Eco/Cooling/Anti Freeze
Schedule	-	ON→Control schedule

Schedule

Mark	Official Name	Meaning
Time	-	Current Time
Thr-diff1	-	Thermo differential 1
Thr-diff2	-	Thermo differential 2
Demand (max%)	-	Maximum capacity demand [%]
Demand	Peak-demand control	Start time - End time
On/Off1	Scheduled operation 1	Operation start time 1 - Operation end time 1
On/Off2	Scheduled operation 2	Operation start time 2 - Operation end time 2
On/Off3	Scheduled operation 3	Operation start time 3 - Operation end time 3
Setting temp1	-	Water temp. setting 1
Setting temp2	-	Water temp. setting 2
Setting temp3	-	Water temp. setting 3

Input(CN142)

Mark	Official Name	Meaning
A1	RUN	Run/Stop
A3	Fan Mode	Forced/Normal
B1	Cooling/Heating switching	ON→Heating/OFF→Cooling
B3	Pump Interlock	Normal/Error
C5	Anti-Freeze	ON/OFF
C6	Capacity	ON→COP priority/OFF→Capacity priority
D3	Flow Switch	Normal/Error
D4	Outlet water temp. switching	ON→2nd(temp.2)/OFF→1st(temp.1)
D5	Demand	ON/OFF
D6	Mode Change	Heating Eco/Heating

Output

Mark	Official Name	Meaning
X01	MAIN BOX= SUB BOX=	MAIN BOX=Solenoid valve(4-way valve) SUB BOX=Solenoid valve(4-way valve)

X02	MAIN BOX=- SUB BOX=	MAIN BOX=Case heater(for heating the compressor) SUB BOX=Case heater(for heating the compressor)
X03	MAIN BOX= SUB BOX=	MAIN BOX=- SUB BOX=-
X04	MAIN BOX=- SUB BOX=	MAIN BOX=Pump operation command output SUB BOX=-
X05	MAIN BOX=- SUB BOX=	MAIN BOX=Drain pan heater signal output SUB BOX=Supplementary heater signal output
X06	MAIN BOX=- SUB BOX=-	MAIN BOX=Operation display output SUB BOX=-
X07	MAIN BOX=- SUB BOX=-	MAIN BOX=Error display output SUB BOX=-
X08	MAIN BOX=- SUB BOX=-	MAIN BOX=Defrost signal output SUB BOX=-
X09	MAIN BOX=- SUB BOX=-	MAIN BOX=Cooling/Heating operation display output SUB BOX=-

12Voutput

Mark	Official Name	Meaning
52C	-	Electromagnetic relay(Inverter main circuit)

Unit condition Unit1 to Unit6

Mark	Official Name	Meaning
TH1	Thermistor	Water inlet temp. 1
TH2	Thermistor	Water inlet temp. 2
TH3	Thermistor	Water outlet temperature
TH5	Thermistor	ACC Inlet Ref temperature
TH6	Thermistor	Air hex Ref temperature
TH7	Thermistor	Water hex Ref temperature
TH10	Thermistor	Outdoor temperature
TH11	Thermistor	Discharge Ref temperature
TH15	Thermistor	External Water sensor
THc1	-	Water Inlet temp. 1 compensation TH1
THc2	-	Water Inlet temp. 2 compensation TH2
THc3	-	Water Outlet temperature compensation TH3
THc15	-	External water temperature compensation TH15
63H1	-	High pressure switch
HP	63HS	High pressure sensor
LP	63LS	Low pressure sensor
Vdc	-	COMP bus voltage [V]
Iu	-	Phase-U current of compressor [A]
Iw	-	Phase-W current of compressor [A]
Ts	-	Target water temperature
Twi	-	Current inlet water temperature
Two	-	Current outlet water temperature
Twg	Main water temperature	External water temperature
Tout	-	Outdoor air temperature by BMS
SHs	-	Target superheat value at the suction pipe to compressor
SCs	-	Target subcool value at the suction pipe to compressor
SH	-	-
SC	-	-
Td-SH	-	Superheat value at the discharge pipe
THHS	Thermistor	IGBT temperature
LEV1	-	Electronic expansion valve(Main/Sub circuit)
COMP1(Hz)	-	Operating frequency in main circuit [Hz]
FAN1(Hz)	-	Operating frequency of fan moter1 [Hz]
FAN2(Hz)	-	Operating frequency of fan moter2 [Hz]
FAN3(Hz)	-	Operating frequency of fan moter3 [Hz]
4-20mA1	-	External analog input for Target water temp (4-20mA1)
0-10V	-	External analog input for Target water temp (0-10V/2-10V)
1-5V	-	External analog input for Target water temp (1-5V)

Operation Status Monitor Terminology (CMB-WP108V-G)

Mark	Official Name	Meaning
TH11	Thermistor sensor	
TH12	Thermistor sensor	
TH13	Thermistor sensor	
TH14	Thermistor sensor	
TH15	Thermistor sensor	
TH16	Thermistor sensor	
TH31a	Thermistor sensor	
TH31b	Thermistor sensor	
TH31c	Thermistor sensor	
TH31d	Thermistor sensor	
TH31e	Thermistor sensor	
TH31f	Thermistor sensor	
TH31g	Thermistor sensor	
TH31h	Thermistor sensor	
TH32	Thermistor sensor	
TH33	Thermistor sensor	
TH34	Thermistor sensor	
TH35	Thermistor sensor	
TH36	Thermistor sensor	
TH37	Thermistor sensor	
Ps1	Pressure sensor	
SWgp1	SWgp1 signal	
SWgp2	SWgp2 signal	
SWgp3	SWgp3 signal	
PS	Power failure detection	
Float	Float SW	
Flcon	Float SW	
Pump11	Pump1 Input	number of rotations
Pump12	Pump2 Input	number of rotations
PumpO1	Pump1 Output	variable for control
PumpO2	Pump2 Output	variable for control
HB Sig	Outdoor unit operation control	Outdoor unit operation control signal to OC
OC Sig	Indoor unit operation control	Indoor unit operation control signal from OC
sigmaQj(C)	Total capacity code (cooling)	Cooling indoor unit capacity
sigmaQj(H)	Total capacity code (heating)	Heating indoor unit capacity
21S4Ma	4 way valve	
21S4Mb	4 way valve	
SVM1	Solenoid valve	
72C	Contactora	
Air vent operation	Air vent operation	The record of air vent operation complete Air vent operation has been completed incomplete Air vent operation has not been completed
Debris removal operation	Debris removal operation	The record of debris removal operation complete Debris removal operation has been completed incomplete Debris removal operation has not been completed

1a-1h	2 way valve MV1*	"0" represents "valve opening = 85" "1" represents "valve opening = 800" "2" represents "valve opening = 1600"
2a-2h	2 way valve MV2*	
3a-3h	3 way valve MV3*	
LEV1	Linear expansion valve	
LEV2	Linear expansion valve	
LEV3	Linear expansion valve	

Operation Status Monitor Terminology (CMB-WP108/1016V-GA1, CMB-WM108/1016V-AA)

Mark	Official Name	Meaning
TH11	Thermistor sensor	Liquid-side refrigerant temp. of Heating-main heat exchanger
TH12	Thermistor sensor	Liquid-side refrigerant temp. of Cooling-main heat exchanger
TH13	Thermistor sensor	Gas-side refrigerant temp. of Heating-main heat exchanger
TH14	Thermistor sensor	Gas-side refrigerant temp. of Cooling-main heat exchanger
TH15	Thermistor sensor	Bypass inlet temperature
TH16	Thermistor sensor	Bypass outlet temperature
TH31a-p	Thermistor sensor	1st-16th port returned water temp.
PS1	Pressure sensor PS1	Detects the high pressure at the liquid side.
PS3	Pressure sensor PS3	Detects the low pressure.
TH32	Thermistor sensor	Outlet water temp. of Heating-main heat exchanger
TH33	Thermistor sensor	Outlet water temp. of Cooling-main heat exchanger
TH34	Thermistor sensor	Water pump 2 discharge water temp.
TH35	Thermistor sensor	Water pump 1 discharge water temp.
SH1	Superheat	Superheat at bypass exit area. TH13-TH11 (only HB)
SH2	Superheat	Superheat at bypass exit area. TH14-TH12 (only HB)
SC1	Subcool	Subcool at liquid entrance area. PT1-TH11 (only HB)
SC2	Subcool	Subcool at liquid entrance area. PT1-TH12 (only HB)
PT1	Average of saturation gas temperature of high pressure and saturation liquid temperature of high pressure	For control of LEV (LEV1,LEV2,LEV3). (only HB)
dPHM	Differential pressure	PS1-PS3 Pressure.(only HB)
PS	Power failure detection	
Float	Float SW	
Fcon	Float SW	
Pump1	Pump1 Input	number of rotations
Pump2	Pump2 Input	number of rotations
PumpO1	Pump1 Output	variable for control
PumpO2	Pump2 Output	variable for control
HB Sig	Outdoor unit operation control	Outdoor unit operation control signal to OC
OC Sig	Indoor unit operation control	Indoor unit operation control signal from OC
sigmaQj(C)	Total capacity code (cooling)	Cooling indoor unit capacity
sigmaQj(H)	Total capacity code (heating)	Heating indoor unit capacity
21S4Ma	4-way valve	Switches the cooling/heating cycle (0:Cooling, 1:Heating)
21S4Mb	4-way valve	Heat exchanger capacity control
SVM1	Solenoid valve	Refrigerant flow volume control
Air vent operation	Air vent operation	The record of air vent operation complete : Air vent operation has been completed incomplete : Air vent operation has not been completed
Debris removal operation	Debris removal operation	The record of debris removal operation complete : Debris removal operation has been completed incomplete : Debris removal operation has not been completed
VB3a-3p	3-way valve MV3*	Controls the water flow path and the water flow rate
LEV1	LEV1 opening	Liquid level control, differential pressure control
LEV2	LEV2 opening	Liquid level control, differential pressure control
LEV3	LEV3 opening	Liquid level control, differential pressure control, superheat of bypass control

Operation Status Monitor Terminology (CMB-WP108/1016V-GB1, CMB-WM108/1016V-AB)

Mark	Official Name	Meaning
TH31a-p	Thermistor sensor	1st-16th port returned water temp.
TH32	Thermistor sensor	Outlet water temp. of Heating-main heat exchanger
TH33	Thermistor sensor	Outlet water temp. of Cooling-main heat exchanger
PS	Power failure detection	
Float	Float SW	
Ficon	Float SW	
VB3a-3p	3-way valve VB3*	Controls the water flow path and the water flow rate
TH31a-p	Thermistor sensor	1st-16th port returned water temp.
TH32	Thermistor sensor	Outlet water temp. of Heating-main heat exchanger
TH33	Thermistor sensor	Outlet water temp. of Cooling-main heat exchanger
PS	Power failure detection	
Float	Float SW	
Ficon	Float SW	

Operation Status Monitor Terminology (CMB-WM350/500F-AA)

Mark	Official Name	Meaning
TH11	Thermistor (Refrigerant side)	Liquid-side refrigerant temperature of Heating-main heat exchanger.
TH12	Thermistor (Refrigerant side)	Liquid-side refrigerant temperature of Cooling-main heat exchanger.
TH13	Thermistor (Refrigerant side)	Gas-side refrigerant temperature of Heating-main heat exchanger.
TH14	Thermistor (Refrigerant side)	Gas-side refrigerant temperature of Cooling-main heat exchanger.
TH15	Thermistor (Refrigerant side)	Bypass inlet temperature.
TH16	Thermistor (Refrigerant side)	Bypass outlet temperature.
TH31a-f	Thermistor (Water side)	1st-6th port returned water temperature.
TH32	Thermistor (Water side)	Outlet water temperature of Heating-main heat exchanger.
TH33	Thermistor (Water side)	Outlet water temperature of Cooling-main heat exchanger.
TH34	Thermistor (Water side)	Water pump 2 discharge water temperature.
TH35	Thermistor (Water side)	Water pump 1 discharge water temperature.
THHS1	Thermistor	Pump1-inverter Heat sink temperature.
THHS2	Thermistor	Pump2-inverter Heat sink temperature.
PS1	Pressure sensor (Refrigerant side)	Refrigerant high pressure at the gas side.
PS3	Pressure sensor (Refrigerant side)	Refrigerant medium pressure.
Pw1(kPa)	Pressure sensor (Water side)	Water pump1 suction water pressure.
Pw2(kPa)	Pressure sensor (Water side)	Water pump1 discharge water pressure.
Pw3(kPa)	Pressure sensor (Water side)	Water pump2 suction water pressure.
Pw4(kPa)	Pressure sensor (Water side)	Water pump2 discharge water pressure.
SH1	Superheat	Superheat at exit area of heat exchanger. TH13-TH11
SH2	Superheat	Superheat at exit area of heat exchanger. TH14-TH12
SC1	Subcool	Subcool at exit area of heat exchanger. PT1-TH11
SC2	Subcool	Subcool at exit area of heat exchanger. PT1-TH12
PT1	Average of saturation gas temperature of high pressure and saturation liquid temperature of high pressure	For control of LEV. (LEV1,LEV2,LEV3)
dPHM	Differential pressure	PS1-PS3 Pressure.
PS	Power failure detection	("OFF" : normal, "ON" : power failure)
PumpO1	Pump1 Output	Variable for control.
PumpO2	Pump2 Output	Variable for control.
Vdc1	Pump1 bus voltage	Pump1 bus voltage. [V]
Iu1	Pump1 U-Phase current effective value	Pump1 U-Phase current effective value. [A]
Iw1	Pump1 W-Phase current effective value	Pump1 W-Phase current effective value. [A]
Vdc2	Pump2 bus voltage	Pump2 bus voltage. [V]
Iu2	Pump2 U-Phase current effective value	Pump2 U-Phase current effective value. [A]
Iw2	Pump2 W-Phase current effective value	Pump2 W-Phase current effective value. [A]
HB Sig	Outdoor unit operation control	Outdoor unit operation control signal to OC.
OC Sig	Indoor unit operation control	Indoor unit operation control signal from OC.
QjC	Total capacity code (cooling)	Cooling indoor unit capacity.
QjH	Total capacity code (heating)	Heating indoor unit capacity.
21S4Ma	4-way valve	Switches the cooling/heating cycle. (0:Heating, 1:Cooling)
21S4Mb	4-way valve	Switches the cooling/heating cycle. (0:Cooling, 1:Heating)
SV1	Solenoid valve	Refrigerant flow volume control.
Air vent operation	Air vent operation	The record of air vent operation. Complete : Air vent operation has been completed Incomplete : Air vent operation has not been completed
Debris removal operation	Debris removal operation	The record of debris removal operation. Complete : Debris removal operation has been completed Incomplete : Debris removal operation has not been completed
MV1	3 way valve MV1	Water supply valve for cooling circuit and heating circuit.
VB3a-f	Valve block VB3*	Controls the water flow path and the water flow rate.
LEV1	LEV1 opening	Liquid level control, differential pressure control.
LEV2	LEV2 opening	Liquid level control, differential pressure control.
LEV3	LEV3 opening	Liquid level control, differential pressure control, superheat of bypass control.
Pump1-Ver	Pump1-inverter board S/W version	Software version of the pump1-inverter board.
Pump2-Ver	Pump2-inverter board S/W version	Software version of the pump2-inverter board.
PS-Ver	Power-supply board S/W version	Software version of the power-supply board.

VB(1)-Ver	Valve-block(1) board S/W version	Software version of the valve-block(1) board.
-----------	----------------------------------	---

Operation Status Monitor Terminology (CMB-WM108/1016V-BB)

Mark	Official Name	Meaning
TH31a-p	Thermistor (Water side)	1st-16th port returned water temperature.
TH32	Thermistor (Water side)	Outlet water temperature of Heating-main heat exchanger.
TH33	Thermistor (Water side)	Outlet water temperature of Cooling-main heat exchanger.
PS	Power failure detection	("OFF" : normal, "ON" : power failure)
Float	Float switch	("OFF" : error, "ON" : normal)
Ficon	Detection of the disconnected float switch	("OFF" : disconnect, "ON" : connect)
VB3a-p	Valve block VB3*	Controls the water flow path and the water flow rate.
VB(1)-Ver	Valve-block(1) board S/W version	Software version of the valve-block(1) board.
VB(2)-Ver	Valve-block(2) board S/W version	Software version of the valve-block(2) board.

Operation Status Monitor Terminology (CMH-WM250/350/500V-A)

Mark	Official Name	Meaning
TH11	Thermistor	Liquid-side refrigerant temp. of heat exchanger
TH13	Thermistor	Gas-side refrigerant temp. of heat exchanger
TH32	Thermistor	Outlet water temp. of heat exchanger
TH35	Thermistor	Water pump discharge water temp.
THHS	Thermistor	Heat sink temperature
PWS(kPa)	Pressure sensor	Water pump suction water pressure
PWD(kPa)	Pressure sensor	Water pump discharge water pressure
Prf	Pressure sensor	Refrigerant pressure at heat exchanger
Trf	Saturation temperature of refrigerant	For control of LEV
SH	Superheat	Superheat at heat exchanger. TH13-Tref
SC	Subcool	Subcool at heat exchanger. Tref-TH11
PS	Power failure detection	Power failure detection
PumpO1	Pump1 Output	variable for control
Vdc	Pump1 bus voltage	Pump1 bus voltage [V]
Iu	U-Phase current effective value	U-Phase current effective value [A]
Iw	W-Phase current effective value	W-Phase current effective value [A]
HU Sig	Outdoor unit operation control	Outdoor unit operation control signal to OC
OC Sig	Indoor unit operation control	Indoor unit operation control signal from OC
QjC	Total capacity code (cooling)	Cooling indoor unit capacity
QjH	Total capacity code (heating)	Heating indoor unit capacity
SV1	Solenoid valve	Refrigerant flow volume control
LEV1	LEV1 opening	Heat exchanger capacity control
Air vent operation	Air vent operation	The record of air vent operation. "complete":Air vent operation has not been completed. "incomplete":Air vent operation has not been completed.
Debris removal operation	Debris removal operation	The record of debris removal operation. "complete":Debris removal operation has been completed. "incomplete":Debris removal operation has not been completed.
Water pressure checking	Water pressure checking	The record of water pressure checking. "complete":Water pressure checking has been completed. "incomplete":Water pressure checking has not been completed.
Water piping length checking	Water piping length checking	The record of water piping length checking. "complete":Water piping length checking has been completed. "incomplete":Water piping length checking has not been completed.
PS-Ver	Power-supply board S/W version	Software version of the power-supply board

Operation Status Monitor Terminology (RBH-P35NRA-Q-TWN,RBS-P20/202HRA-Q-TWN)

Mark	Official Name	Meaning
MODEL CODE (Unit code)	-	06(STD08)
Ver	Software Version	Main program ROM version
TH1	Thermistor	Room temperature (Air temperature measured by thermistor)
TH2	End of defrosting1	Defrost end(1)/Other(0)
TH3	End of defrosting2	Defrost end(1)/Other(0)
TH4	Model(Unit) setting	Model setting input
THe	Analog input1	Blank
4-20	Analog input2	Blank
SET TEMP.	Room temperature setting	Target room temperature (Cut-off value)
DATE	-	Current Time
F	Time setup flag	Current Time Set up(1)/Unset up(0)
DIFF.	Room temperature difference	Differential of room temperature ((Cut-in value) - (Cut-off value))
SETBACK	Setback value	Setting value of setback operation
TEMP ALARM	Difference of high temperature alarm	Setting value of high temperature alarm
TEMP SHIFT	Temperature shift value	Setting value of tenperature shift operation
COOLING TIME	Normal operation start time	Time to change setback operation to normal operation
SETBACK TIME	Setback operation start time	Time to change normal operation to setback operation
DEFROST TIME	Defrosting start time	Time to start defrost cycle in the case of fixed time defrost
DEF.CYCLE	Defrost cycle	Defrost cycle in the case of cycle defrost [hour]
DEF.TIME	Defrost time[minute]	Defrost time for offcycle defrosting. For defrosting with heater, it shows the backup time to finish defrosting
WATER DRIP	Water drip time [minute]	Unit stop time after defrost mode, to prevent drain water flooding
FAN DELAY	Fan start delay time [minute]	Fan start delay time from the unit starts cooling after defrost cycle [minute]
INTERVAL	Restart delay time setting	Restart delay time from the unit goes into Thermo-OFF [second]
INT.THERM	Intelligent timer preset value	Setting value of intelligence time function
RT CORRECT	Room temperature correction	Room temperature correction value [degree]
X6	External abnormalities	Condensing unit is unusual(1)/usual(0)
X7	Compressor ON/OFF	One or more compressors are Running(1)/Stop(0)
IN3	External contact input	Set up(1)/Unset up(0)
IN4	(Reserve)	Blank
LEV	Linear expansion valve	Linear expansion valve output [pulse]
UCNo.	Unit controller number	Unit controller number (1 to 4)
SW1	Setting of dip-switch 1	Setting of dip-switch 1 (Refer to Technical Manual and Instruction Manual for more information)
SW2	Setting of dip-switch 2	Setting of dip-switch 2 (Refer to Technical Manual and Instruction Manual for more information)
TEMP RANGE	Unit setting	Setting of temperature range (High/Low/Extra low temperature)
OPE. CODE	Operation code	The code of operational status
COMP START	Number of compressor starts	Number of compressor starts
LiqSV ON/OFF	Solenoid valve (liquid) ON time/OFF time	Solenoid valve (liquid) ON time/OFF time of the previous day [hour/hour]
HeaterON/OFF	Heater ON time/OFF time	Defrost heater ON time/OFF time of the previous day [hour/hour]
TH1 MAX,MIN	MAX/MIN value of room temperature	MAX,MIN value of room temperature of the previous day [degree]
X1	Control source output	-
X2	Solenoid valve (liquid) output	-
X3	Cooler fan output	-
X4	Defrost heater output1	-
X5	Defrost heater output2	-
X30	Alarm output1	Condensing unit is unusual(1)/usual(0)
X31	Alarm output2	High temperature alarm(1)/usual(0)
X32	Alarm output3	High temperature error (50°C)(1)/usual(0)
12-1	Driver output1 (DC12V)	Warning buzzer output
12-2	Driver output2 (DC12V)	Blank
12-3	Driver output2 (DC12V)	Blank

Operation Status Monitor Terminology(P-series)

Mark	Official Name	Meaning
action	Operation state(action)	Operation state of Unit
mode	Operation mode	Operation mode of Unit
TO	Setting temperature	Setting temperature of Unit
capacity save(%)	Capacity save	Signal of capacity saving from system controller. figure : %, No signal : 100%
TH1	Indoor room temperature	Detects the room temperature and performs thermo judgment based on the difference from the set temperature. The display temperature varies depending on the room temperature detect position of function selecting.
TH2	Indoor pipe temperature	Indoor pipe temperature In case of multiple indoor units connection, average value is displayed.
TH5	Indoor 2-phase pipe temperature	Indoor 2-phase pipe temperature
COMP	Compressor state	Compressor state "ON" indication at compressor operation
21S4	4way valve state	4way valve state "ON" indication at heating side
SV	Solenoid valve state	Solenoid valve state "ON" indication at solenoid valve operation
FAN	Fan step	Fan step of Outdoor unit
Hz	Target frequency	Target Compressor frequency
49C	Inner thermo	Inner thermo(compressor) state Normally "closed" indication, operation "open" indication
63H	63H protection state	High pressure protection state Normally "closed" indication, operation "open" indication
63L	63L protection state	Low pressure protection state Normally "closed" indication, operation "open" indication
63HS	Pressure saturation temperature	Pressure saturation temperature of Outdoor unit
LEV A	LEV opening (A)	LEV opening(A) of Outdoor unit
LEV B	LEV opening (B)	LEV opening (B) of Outdoor unit
LEV C	LEV opening (C)	LEV opening (C) of Outdoor unit
TH3	Liquid temperature	Liquid temperature of Outdoor unit
TH4	Discharge temperature	Discharge temperature of Outdoor unit
TH5	Indoor pipe temperature	Indoor pipe temperature of Outdoor unit
TH6	2-phase pipe temperature	2-phase pipe temperature of Outdoor unit
TH7	Ambient temperature	Ambient temperature of Outdoor unit
TH8	Heat sink temperature	Heat sink temperature of Outdoor unit
TH32	Suction pipe temperature	Suction pipe temperature
TH33	Comp. surface temperature	Comp. surface temperature
SHd(SH)	Discharge superheat	Discharge superheat
SC	Subcool	Subcool
COMP(A)	Secondary current	Secondary current
Last Error Adrs	Last Error Address	Unit address where the error occurred after turn ON (Latest value only)
Last Error Code	Last Error Code	Error code after turn ON(Latest value only)

*Depending on the model, the monitor Mark and display value may not match.

*Depending on the model, Monitorable data is different.

*The model name displayed on the monitor may not match the actual model name.

Operation Status Monitor Terminology(M-series)

Mark	Official Name	Unit
DiscTemp	Discharge temperature	°C/°F
TgtDiscTemp	Target discharge temperature	°C/°F
PrognoDiscTemp	Prognostic discharge temperature	°C/°F
DefTemp	Defrost temperature	°C/°F
FinTemp	Fin temperature	°C/°F
PCbordTemp	PC board temperature	°C/°F
AmbientTemp	Ambient temperature	°C/°F
OutHEXtemp	Outdoor Hexadecimal temp	°C/°F
EvaTemp	Evaporation temperature	°C/°F
CoilTemp_main	Coil temperature [MAIN]	°C/°F
CoilTemp_sub	Coil temperature [SUB]	°C/°F
RoomTemp	Room temperature	°C/°F
Set-RoomTemp	Set temp - room temp	°C/°F
Compfreq	Compressor frequency	Hz
Compfreq_Uplim	Upper limit compressor frequency	Hz
Compfreq_Dnlim	Lower limit compressor frequency	Hz
PriCurrent	Outdoor primary current	A
LEV_M	LEV M opening	pulse
FanSPD	Outdoor fan speed	rpm
H/L_Bypass_St	H/L bypass valve control State	-
H/L_Bypass2_St	H/L bypass valve control 2 State	-
LEVOpening	LEV opening	Pulse
FanSPDCode	Fan speed code	-
HP_ProtecCode	High pressure protection code	-
Dryness_ProtecCode	Dryness protection code	-
Frost_PreventCode	Frost prevention code	-
ProtecCode(Lower)	Protection code	-
ProtecCode(Upper)		-
FaultStopInfo(Lower)	Fault stop information	-
FaultStopInfo(Upper)		-
ProtecStopInfo(Lower)	Protection stop information	-
ProtecStopInfo(Upper)		-

*Depending on the model, Monitorable data is different.

<For USA>

fiscal_year	series	model	Relay cable	Connector
2005	MUZ-A24 RAC-A(1)	MUY/MUZ-A24NA(-1/U1)	Type AD	CN605
2005	MUZ-A24 RAC-A(2)	MUY/MUZ-A24NA(-1/U1)	Type AD	CN605
2005	MUZ-A24 RAC-A(3)	MUY/MUZ-A24NA(-1/U1)	Type AD	CN605
2005	MUZ-D(GA) big rac	MUZ-D30/36NA(-1/-U1/-U2) GA24NA(-U1)	Type AD	CN605
2005	GE small rac	MUZ-GE09/12/15/18NA(-U1)	Type AD	CN606
2005	MUZ-A09/12/15/17NA small rac(1)	MUZ-A09/12/15/17NA(-1/-U1/-U2)	Type AD	CN606
2005	MUZ-A09/12/15/17NA small rac(2)	MUZ-A09/12/15/17NA(-1/-U1/-U2)	Type AD	CN606
2005	MUZ-A09/12/15/17NA small rac(3)	MUZ-A09/12/15/17NA(-1/-U1/-U2)	Type B	CN606
2005	MUZ-FD09/12NA(-U1) small rac	MUZ-FD09/12NA(-U1)	Type B	CN606
2008	SUZ-KA25NA.TH	SUZ-KA25NA.TH	Type AD	CN606
2008	SUZ-KA35NA.TH	SUZ-KA35NA.TH	Type AD	CN606
2008	SUZ-KA50NA.TH	SUZ-KA50NA.TH	Type B	CN606
2008	SUZ-KA60NA.TH	SUZ-KA60NA.TH	Type B	CN605
2008	SUZ-KA71NA.TH	SUZ-KA71NA.TH	Type B	CN605
2009	MUY-D30NA-1	MUY-D30NA-1	Type AD	CN605
2009	MUY-D36NA-1	MUY-D36NA-1	Type AD	CN605
2009	MUY-GA24NA	MUY-GA24NA	Type AD	CN605
2009	MUY-GE09NA	MUY-GE09NA	Type AD	CN606
2009	MUY-GE12NA	MUY-GE12NA	Type AD	CN606
2009	MUY-GE15NA	MUY-GE15NA	Type AD	CN606
2009	MUY-GE18NA	MUY-GE18NA	Type AD	CN606
2009	MUZ-D30NA-1	MUZ-D30NA-1	Type AD	CN605
2009	MUZ-D30NA-U2	MUZ-D30NA-U2	Type AD	CN605
2009	MUZ-D36NA-1	MUZ-D36NA-1	Type B	CN605
2009	MUZ-D36NA-U2	MUZ-D36NA-U2	Type B	CN605
2009	FE small rac	MUZ-FE09/12NA	Type B	CN606
2009	MUZ-FE09NA	MUZ-FE09NA	Type B	CN606
2009	MUZ-FE12NA	MUZ-FE12NA	Type B	CN606
2009	MUZ-GA24NA	MUZ-GA24NA	Type B	CN605
2009	MUZ-GA24NA-U1	MUZ-GA24NA-U1	Type B	CN605
2009	MUZ-GE09NA	MUZ-GE09NA	Type B	CN606
2009	MUZ-GE12NA	MUZ-GE12NA	Type B	CN606
2009	MUZ-GE15NA	MUZ-GE15NA	Type B	CN606
2009	MUZ-GE18NA	MUZ-GE18NA	Type B	CN606
2010	SUZ-KA09NA.TH	SUZ-KA09NA.TH	Type B	CN606
2010	SUZ-KA09NA.TH H	SUZ-KA09NA.TH H	Type B	CN606
2010	SUZ-KA12NA.TH	SUZ-KA12NA.TH	Type B	CN606
2010	SUZ-KA12NA.TH H	SUZ-KA12NA.TH H	Type B	CN606
2010	SUZ-KA15NA.TH	SUZ-KA15NA.TH	Type B	CN606
2010	SUZ-KA15NA.TH H	SUZ-KA15NA.TH H	Type B	CN606
2010	SUZ-KA18NA.TH	SUZ-KA18NA.TH	Type B	CN606
2010	SUZ-KA18NA.TH H	SUZ-KA18NA.TH H	Type B	CN606
2011	MUY-GE15NA-1	MUY-GE15NA-1	Type B	CN606
2011	MUY-GE18NA-1	MUY-GE18NA-1	Type B	CN606
2011	MUY-GE24NA	MUY-GE24NA	Type C	CN806
2011	MUZ-FE09NA H	MUZ-FE09NA H	Type B	CN606

fiscal_year	series	model	Relay cable	Connector
2011	MUZ-FE09NA-1	MUZ-FE09NA-1	Type B	CN606
2011	MUZ-FE12NA H	MUZ-FE12NA H	Type B	CN606
2011	MUZ-FE12NA1	MUZ-FE12NA1	Type B	CN606
2011	MUZ-FE18NA	MUZ-FE18NA	Type C	CN806
2011	MUZ-GE09NA H	MUZ-GE09NA H	Type B	CN606
2011	MUZ-GE12NA H	MUZ-GE12NA H	Type B	CN606
2011	MUZ-GE15NA H	MUZ-GE15NA H	Type B	CN606
2011	MUZ-GE15NA-1	MUZ-GE15NA-1	Type B	CN606
2011	MUZ-GE18NA H	MUZ-GE18NA H	Type B	CN606
2011	MUZ-GE18NA-1	MUZ-GE18NA-1	Type B	CN606
2011	MUZ-GE24NA	MUZ-GE24NA	Type C	CN806
2012	MUZ-FE09NAH	MUZ-FE09NAH	Type B	CN606
2012	MUZ-FE12NAH	MUZ-FE12NAH	Type B	CN606
2012	MUZ-GE09NAH	MUZ-GE09NAH	Type B	CN606
2012	MUZ-GE12NAH	MUZ-GE12NAH	Type B	CN606
2012	MUZ-GE15NAH	MUZ-GE15NAH	Type B	CN606
2012	MUZ-GE18NAH	MUZ-GE18NAH	Type B	CN606
2013	MUZ-FE18NA H	MUZ-FE18NA H	Type C	CN806
2013	MUZ-FH09NA	MUZ-FH09NA	Type C	CN606
2013	MUZ-FH09NAH	MUZ-FH09NAH	Type C	CN606
2013	MUZ-FH12NA	MUZ-FH12NA	Type C	CN606
2013	MUZ-FH12NAH	MUZ-FH12NAH	Type C	CN606
2013	MUZ-FH15NA	MUZ-FH15NA	Type C	CN806
2013	MUZ-FH15NAH	MUZ-FH15NAH	Type C	CN806
2013	MUZ-GE24NA H	MUZ-GE24NA H	Type C	CN806
2014	MUY-GE09NA2	MUY-GE09NA2	Type B	CN606
2014	MUY-GE12NA2	MUY-GE12NA2	Type B	CN606
2014	MUY-GE15NA2	MUY-GE15NA2	Type B	CN606
2014	MUZ-GE09NA2	MUZ-GE09NA2	Type B	CN606
2014	MUZ-GE09NAH2	MUZ-GE09NAH2	Type B	CN606
2014	MUZ-GE12NA2	MUZ-GE12NA2	Type B	CN606
2014	MUZ-GE12NAH2	MUZ-GE12NAH2	Type B	CN606
2014	MUZ-GE15NA2	MUZ-GE15NA2	Type B	CN606
2014	MUZ-GE15NAH2	MUZ-GE15NAH2	Type B	CN606
2014	MUZ-HE09NA	MUZ-HE09NA	Type B	CN606
2014	MUZ-HE12NA	MUZ-HE12NA	Type B	CN606
2014	MUZ-HE15NA	MUZ-HE15NA	Type C	CN606
2014	MUZ-HE18NA	MUZ-HE18NA	Type B	CN606
2014	MUZ-HE24NA	MUZ-HE24NA	Type B	CN806
2015	MUY-GL18NA-U1	MUY-GL18NA-U1	Type C	CN606
2015	MUY-GL24NA-U1	MUY-GL24NA-U1	Type AD	CN806
2015	MUZ-FH18NA	MUZ-FH18NA	Type AD	CN806
2015	MUZ-FH18NA2	MUZ-FH18NA2	Type AD	CN806
2015	MUZ-FH18NAH	MUZ-FH18NAH	Type AD	CN806
2015	MUZ-FH18NAH2	MUZ-FH18NAH2	Type C	CN806
2015	MUZ-GL18NAH-U1	MUZ-GL18NAH-U1	Type AD	CN606
2015	MUZ-GL18NA-U1	MUZ-GL18NA-U1	Type C	CN606
2015	MUZ-GL24NAH-U1	MUZ-GL24NAH-U1	Type C	CN806
2015	MUZ-GL24NA-U1	MUZ-GL24NA-U1	Type C	CN806
2015	MUZ-HM24NA-U1	MUZ-HM24NA-U1	Type C	CN606
2015	MXZ-2B20NA	MXZ-2B20NA	Type AD	CN605
2015	MXZ-2B20NA-1	MXZ-2B20NA-1	Type AD	CN605
2015	MXZ-2B20NA-2	MXZ-2B20NA-2	Type AD	CN605

fiscal_year	series	model	Relay cable	Connector
2015	MXZ-2C20NAHZ	MXZ-2C20NAHZ	Type C	CN861
2015	MXZ-2C20NAHZ2-U1	MXZ-2C20NAHZ2-U1	Type C	CN861
2015	MXZ-3B24NA	MXZ-3B24NA	Type AD	CN606
2015	MXZ-3B24NA-1 (a)	MXZ-3B24NA-1 (a)	Type AD	CN606
2015	MXZ-3B24NA-1 (b)	MXZ-3B24NA-1 (b)	Type C	CN605
2015	MXZ-3B30NA	MXZ-3B30NA	Type AD	CN605
2015	MXZ-3B30NA-1 (a)	MXZ-3B30NA-1 (a)	Type AD	CN605
2015	MXZ-3B30NA-1 (b)	MXZ-3B30NA-1 (b)	Type C	CN605
2015	MXZ-3C24NA	MXZ-3C24NA	Type C	CN861
2015	MXZ-3C24NA2-U1	MXZ-3C24NA2-U1	Type C	CN861
2015	MXZ-3C24NAHZ	MXZ-3C24NAHZ	Type C	CN861
2015	MXZ-3C24NAHZ2-U1	MXZ-3C24NAHZ2-U1	Type C	CN861
2015	MXZ-3C30NA	MXZ-3C30NA	Type C	CN861
2015	MXZ-3C30NA2-U1	MXZ-3C30NA2-U1	Type C	CN861
2015	MXZ-3C30NAHZ	MXZ-3C30NAHZ	Type C	CN861
2015	MXZ-3C30NAHZ2-U1	MXZ-3C30NAHZ2-U1	Type C	CN861
2015	MXZ-4B36NA	MXZ-4B36NA	Type C	CN861
2015	MXZ-4B36NA-1 (a)	MXZ-4B36NA-1 (a)	Type C	CN861
2015	MXZ-4B36NA-1 (b)	MXZ-4B36NA-1 (b)	Type C	CN605
2015	MXZ-4C36NA	MXZ-4C36NA	Type C	CN861
2015	MXZ-4C36NA2-U1	MXZ-4C36NA2-U1	Type C	CN861
2015	MXZ-5B42NA	MXZ-5B42NA	Type C	CN861
2015	MXZ-5C42NA	MXZ-5C42NA	Type C	CN861
2015	MXZ-5C42NA2-U1	MXZ-5C42NA2-U1	Type C	CN861
2015	MUZ-GL18NAH	MUZ-GL18NAH	Type C	CN606
2016	MUZ-HM24NA2-U1	MUZ-HM24NA2-U1	Type C	CN606
2016	MUZ-HM09NA-U8	MUZ-HM09NA-U8	Type B	CN606
2016	MUZ-HM09NA2-U8	MUZ-HM09NA2-U8	Type B	CN606
2016	MUZ-HM12NA-U8	MUZ-HM12NA-U8	Type B	CN606
2016	MUZ-HM12NA2-U8	MUZ-HM12NA2-U8	Type B	CN606
2016	MUZ-HM24NA-U1	MUZ-HM24NA-U1	Type C	CN606
2016	MUFZ-KJ09NAHZ-U1	MUFZ-KJ09NAHZ-U1	Type C	CN606
2016	MUFZ-KJ12NAHZ-U1	MUFZ-KJ12NAHZ-U1	Type C	CN606
2016	MUFZ-KJ15NAHZ-U1	MUFZ-KJ15NAHZ-U1	Type C	CN806
2016	MUFZ-KJ18NAHZ-U1	MUFZ-KJ18NAHZ-U1	Type C	CN806
PIMS2016	MUZ-FH09NA-1	MUZ-FH09NA-1	Type C	CN606
PIMS2016	MUZ-FH09NAH-1	MUZ-FH09NAH-1	Type C	CN606
PIMS2016	MUZ-FH12NA-1	MUZ-FH12NA-1	Type C	CN606
PIMS2016	MUZ-FH12NAH-1	MUZ-FH12NAH-1	Type C	CN606
PIMS2016	MUZ-GL09NAH-U1	MUZ-GL09NAH-U1	Type C	CN606
PIMS2016	MUZ-GL12NAH-U1	MUZ-GL12NAH-U1	Type C	CN606
PIMS2016	MUZ-GL15NAH-U1	MUZ-GL15NAH-U1	Type C	CN606
PIMS2016	MUY-GL09NA-U1	MUY-GL09NA-U1	Type C	CN606
PIMS2016	MUY-GL12NA-U1	MUY-GL12NA-U1	Type C	CN606
PIMS2016	MUY-GL15NA-U1	MUY-GL15NA-U1	Type C	CN606
PIMS2016	MUZ-GL09NA-U1	MUZ-GL09NA-U1	Type C	CN606
PIMS2016	MUZ-GL12NA-U1	MUZ-GL12NA-U1	Type C	CN606
PIMS2016	MUZ-GL15NA-U1	MUZ-GL15NA-U1	Type C	CN606
PIMS2016	MUZ-HM09NA-U1	MUZ-HM09NA-U1	Type C	CN606
PIMS2016	MUZ-HM12NA-U1	MUZ-HM12NA-U1	Type C	CN606
PIMS2016	MUZ-HM15NA-U1	MUZ-HM15NA-U1	Type C	CN606
PIMS2016	MUY-HM09NA-L1	MUY-HM09NA-L1	Type C	CN606
PIMS2016	MUY-HM12NA-L1	MUY-HM12NA-L1	Type C	CN606

fiscal_year	series	model	Relay cable	Connector
PIMS2016	MUY-HM15NA-L1	MUY-HM15NA-L1	Type C	CN606
PIMS2016	MUZ-HM18NA-U1	MUZ-HM18NA-U1	Type C	CN606
PIMS2016	MUY-HM18NA-L1	MUY-HM18NA-L1	Type C	CN606
PIMS2016	MUZ-HM09NA2-U1	MUZ-HM09NA2-U1	Type C	CN606
PIMS2016	MUZ-HM12NA2-U1	MUZ-HM12NA2-U1	Type C	CN606
PIMS2016	MUZ-HM15NA2-U1	MUZ-HM15NA2-U1	Type C	CN606
PIMS2016	MUZ-HM18NA2-U1	MUZ-HM18NA2-U1	Type C	CN606
PIMS2016	MUZ-FH06NA	MUZ-FH06NA	Type C	CN606
PIMS2016	MUZ-FH06NAH	MUZ-FH06NAH	Type C	CN606
PIMS2016	MUZ-GL09NA-U8	MUZ-GL09NA-U8	Type C	CN606
PIMS2016	MUZ-GL09NAH-U8	MUZ-GL09NAH-U8	Type C	CN606
2017	MXZ-2C20NA2-U1	MXZ-2C20NA2-U1	Type C	CN861
2017	MUY-HM24NA-L1	MUY-HM24NA-L1	Type C	CN606
2018	MUZ-GL24NA-U2	MUZ-GL24NA-U2	Type C	CN806
2018	MUZ-JP09WA-U1	MUZ-JP09WA-U1	Type C	CN606
2018	MUZ-JP12WA-U1	MUZ-JP12WA-U1	Type C	CN606
2018	MUZ-WR09NA-U1	MUZ-WR09NA-U1	Type C	CN606
2018	MUZ-WR12NA-U1	MUZ-WR12NA-U1	Type C	CN606
2018	MUZ-WR18NA-U1	MUZ-WR18NA-U1	Type C	CN606
2018	MUZ-WR24NA-U1	MUZ-WR24NA-U1	Type C	CN606
2018	SUZ-KA09NA2.MX	SUZ-KA09NA2.MX	Type C	CN606
2018	SUZ-KA09NAH2.MX	SUZ-KA09NAH2.MX	Type C	CN606
2018	SUZ-KA09NAR1.TH	SUZ-KA09NAR1.TH	Type C	CN606
2018	SUZ-KA09NAR1.TH H	SUZ-KA09NAR1.TH H	Type C	CN606
2018	SUZ-KA12NA2.MX	SUZ-KA12NA2.MX	Type C	CN606
2018	SUZ-KA12NAH2.MX	SUZ-KA12NAH2.MX	Type C	CN606
2018	SUZ-KA12NAR1.TH	SUZ-KA12NAR1.TH	Type C	CN606
2018	SUZ-KA12NAR1.TH H	SUZ-KA12NAR1.TH H	Type C	CN606
2018	SUZ-KA15NA2.MX	SUZ-KA15NA2.MX	Type C	CN606
2018	SUZ-KA15NAH2.MX	SUZ-KA15NAH2.MX	Type C	CN606
2018	SUZ-KA15NAR1.TH	SUZ-KA15NAR1.TH	Type C	CN606
2018	SUZ-KA15NAR1.TH H	SUZ-KA15NAR1.TH H	Type C	CN606
2018	SUZ-KA18NAR1.TH	SUZ-KA18NAR1.TH	Type C	CN606
2018	SUZ-KA18NAR1.TH H	SUZ-KA18NAR1.TH H	Type C	CN606
2019	MUY-GL09NA-U2	MUY-GL09NA-U2	Type C	CN606
2019	MUY-GL12NA-U2	MUY-GL12NA-U2	Type C	CN606
2019	MUY-GL15NA-U2	MUY-GL15NA-U2	Type C	CN606
2019	MUZ-GL09NAH-U2	MUZ-GL09NAH-U2	Type C	CN606
2019	MUZ-GL09NA-U2	MUZ-GL09NA-U2	Type C	CN606
2019	MUZ-GL12NAH-U2	MUZ-GL12NAH-U2	Type C	CN606
2019	MUZ-GL12NA-U2	MUZ-GL12NA-U2	Type C	CN606
2019	MUZ-GL15NAH-U2	MUZ-GL15NAH-U2	Type C	CN606
2019	MUZ-GL15NA-U2	MUZ-GL15NA-U2	Type C	CN606
2019	MUZ-HM09NAH-U1	MUZ-HM09NAH-U1	Type C	CN606
2019	MUZ-HM09NA-U2	MUZ-HM09NA-U2	Type C	CN606
2019	MUZ-HM12NAH-U1	MUZ-HM12NAH-U1	Type C	CN606
2019	MUZ-HM12NA-U2	MUZ-HM12NA-U2	Type C	CN606
2019	MUZ-HM15NAH-U1	MUZ-HM15NAH-U1	Type C	CN606
2019	MUZ-HM15NA-U2	MUZ-HM15NA-U2	Type C	CN606
2019	MUZ-HM18NAH-U1	MUZ-HM18NAH-U1	Type C	CN606
2019	MUZ-HM18NA-U2	MUZ-HM18NA-U2	Type C	CN606
2019	MUZ-HM24NAH-U1	MUZ-HM24NAH-U1	Type C	CN606
2019	MUZ-WR09NA-U2	MUZ-WR09NA-U2	Type C	CN606

fiscal_year	series	model	Relay cable	Connector
2019	MUZ-WR12NA-U2	MUZ-WR12NA-U2	Type C	CN606
2019	MUZ-WR18NA-U2	MUZ-WR18NA-U2	Type C	CN606
2019	SUZ-KA09NAHZ.TH	SUZ-KA09NAHZ.TH	Type C	CN606
2019	SUZ-KA12NAHZ.TH	SUZ-KA12NAHZ.TH	Type C	CN606
2019	SUZ-KA15NAHZ.TH	SUZ-KA15NAHZ.TH	Type C	CN806
2019	SUZ-KA18NAHZ.TH	SUZ-KA18NAHZ.TH	Type C	CN806
2020	SUZ-KA18NA2.TH	SUZ-KA18NA2.TH	Type C	CN606
2020	SUZ-KA18NAH2.TH	SUZ-KA18NAH2.TH	Type C	CN606
2020	SUZ-KA24NA2.TH	SUZ-KA24NA2.TH	Type C	CN806
2020	SUZ-KA24NAH2.TH	SUZ-KA24NAH2.TH	Type C	CN806
2020	SUZ-KA30NA2.TH	SUZ-KA30NA2.TH	Type C	CN806
2020	SUZ-KA30NAH2.TH	SUZ-KA30NAH2.TH	Type C	CN806
2020	SUZ-KA36NA2.TH	SUZ-KA36NA2.TH	Type C	CN806
2020	SUZ-KA36NAH2.TH	SUZ-KA36NAH2.TH	Type C	CN806

<For Europe>

fiscal_year	series	model	Relay cable	Connector
2005	MUZ-FA GA KA small RAC(1)	MUZ-FA GA25/35VA(H) GB/HA/GC35VA(H) SUZ25	Type AD	CN606
2005	MUZ-FA GA KA small RAC(2)	MUZ-FA GA25/35VA(H) SUZ25	Type AD	CN606
2005	MUZ-FA GA KA small RAC(3)	MUZ-FA GA25/35VA(H) SUZ25	Type AD	CN606
2005	MUZ-FB25/35	MUZ-FB25/35VA(H)-E1,E2	Type B	CN606
2005	MUZ-FD25/35VABH	MUZ-FD25/35VABH-E1	Type B	CN606
2005	MUZ-FD50	MUZ-FD50VA(BH)-E1	Type AD	CN605
2005	MUZ-GA GB big RAC-A(1)	MUZ-GA50VA-E1/GA60VA-E1,E2 /GA71VA-E1,E2/GB50VA-E1,E2	Type AD	CN605
2005	MUZ-GA GB big RAC-A(2)	MUZ-GA50VA-E1/GA60VA-E1,E2 /GA71VA-E1,E2/GB50VA-E1,E2	Type AD	CN605
2005	MUZ-GA GB big RAC-A(3)	MUZ-GA50VA-E1/GA60VA-E1,E2 /GA71VA-E1,E2/GB50VA-E1,E2	Type AD	CN605
2005	MUZ-GA60VA big RAC-B	MUZ-GA60VA-E3	Type AD	CN605
2005	MUZ-GB50/FB35/GE	MUZ-GB50VA/FB35VAH/GE25/35/42/50VA(H)	Type B	CN606
2005	MUZ-HC GC FD small RAC	MUZ-HC FD25/35VA(H) GC25VA(H)	Type B	CN606
2005	SUZ-KA25VA.TH	SUZ-KA25VA.TH	Type AD	CN606
2005	SUZ-KA25VAH.TH	SUZ-KA25VAH.TH	Type AD	CN606
2005	SUZ-KA35VA.TH	SUZ-KA35VA.TH	Type AD	CN606
2005	SUZ-KA35VAH.TH	SUZ-KA35VAH.TH	Type AD	CN606
2005	SUZ-KA50VA.TH	SUZ-KA50VA.TH	Type AD	CN605
2005	SUZ-KA60VA.TH	SUZ-KA60VA.TH	Type AD	CN605
2005	SUZ-KA71VA.TH	SUZ-KA71VA.TH	Type AD	CN605
2007	MUZ-GA71VA-E2	MUZ-GA71VA-E2	Type AD	CN605
2007	MUZ-GC25VA-E1	MUZ-GC25VA-E1	Type B	CN606
2007	MUZ-GC35VA-E1	MUZ-GC35VA-E1	Type AD	CN606
2007	MUZ-HC25VA-E1	MUZ-HC25VA-E1	Type B	CN606
2007	MUZ-HC35VAB-E1	MUZ-HC35VAB-E1	Type B	CN606
2007	SUZ-KA50VA#1.TH	SUZ-KA50VA#1.TH	Type AD	CN605
2007	SUZ-KA60VA#1.TH	SUZ-KA60VA#1.TH	Type AD	CN605
2007	SUZ-KA71VA#1.TH	SUZ-KA71VA#1.TH	Type AD	CN605
2008	MUZ-FD25VABH-E1	MUZ-FD25VABH-E1	Type B	CN606
2008	MUZ-FD25VA-E1	MUZ-FD25VA-E1	Type B	CN606
2008	MUZ-FD25VAH-E1	MUZ-FD25VAH-E1	Type B	CN606
2008	MUZ-FD35VABH-E1	MUZ-FD35VABH-E1	Type B	CN606
2008	MUZ-FD35VA-E1	MUZ-FD35VA-E1	Type B	CN606
2008	MUZ-FD35VAH-E1	MUZ-FD35VAH-E1	Type B	CN606
2008	MUZ-FD50VABH-E1	MUZ-FD50VABH-E1	Type AD	CN605
2008	MUZ-GA60VA-E3	MUZ-GA60VA-E3	Type AD	CN605
2008	MUZ-GB50VA-E3	MUZ-GB50VA-E3	Type B	CN606
2008	MUZ-HC35VAB-E2	MUZ-HC35VAB-E2	Type B	CN606
2008	MUZ-HC35VA-E2	MUZ-HC35VA-E2	Type B	CN606
2008	SUZ-KA25VAHR1.TH	SUZ-KA25VAHR1.TH	Type B	CN606
2008	SUZ-KA25VAR1.TH	SUZ-KA25VAR1.TH	Type B	CN606
2008	SUZ-KA35VAHR1.TH	SUZ-KA35VAHR1.TH	Type B	CN606
2008	SUZ-KA35VAR1.TH	SUZ-KA35VAR1.TH	Type B	CN606
2008	SUZ-KA50VAR2.TH	SUZ-KA50VAR2.TH	Type B	CN606
2008	SUZ-KA60VAR2.TH	SUZ-KA60VAR2.TH	Type AD	CN605
2009	MUZ 09model	MUZ-GE25/35/42/50/60/71VA(H)-E1	Type C	CN605
2009	MUZ-FD50VA-E1	MUZ-FD50VA-E1	Type AD	CN605
2009	MUZ-GE25VA-E1	MUZ-GE25VA-E1	Type B	CN606
2009	MUZ-GE25VAH-E1	MUZ-GE25VAH-E1	Type B	CN606
2009	MUZ-GE35VA-E1	MUZ-GE35VA-E1	Type B	CN606
2009	MUZ-GE35VAH-E1	MUZ-GE35VAH-E1	Type B	CN606

fiscal_year	series	model	Relay cable	Connector
2009	MUZ-GE42VA-E1	MUZ-GE42VA-E1	Type B	CN606
2009	MUZ-GE42VAH-E1	MUZ-GE42VAH-E1	Type B	CN606
2009	MUZ-GE50VA-E1	MUZ-GE50VA-E1	Type B	CN606
2009	MUZ-GE50VAH-E1	MUZ-GE50VAH-E1	Type B	CN606
2010	MUZ-GE60VA-E1	MUZ-GE60VA-E1	Type C	CN806
2010	MUZ-GE71VA-E1	MUZ-GE71VA-E1	Type C	CN806
2010	SUZ-KA25VA2.TH	SUZ-KA25VA2.TH	Type B	CN606
2010	SUZ-KA35VA2.TH	SUZ-KA35VA2.TH	Type B	CN606
2010	SUZ-KA50VA2.TH	SUZ-KA50VA2.TH	Type B	CN606
2010	SUZ-KA60VA2.TH	SUZ-KA60VA2.TH	Type AD	CN605
2010	SUZ-KA71VA2.TH	SUZ-KA71VA2.TH	Type C	CN806
2011	MUZ-EF25VE-E1	MUZ-EF25VE-E1	Type C	CN606
2011	MUZ-EF25VEH-E1	MUZ-EF25VEH-E1	Type C	CN606
2011	MUZ-EF35VE-E1	MUZ-EF35VE-E1	Type C	CN606
2011	MUZ-EF35VEH-E1	MUZ-EF35VEH-E1	Type C	CN606
2011	MUZ-EF42VE-E1	MUZ-EF42VE-E1	Type C	CN606
2011	MUZ-EF50VE-E1	MUZ-EF50VE-E1	Type C	CN606
2012	MUZ-FH25VE-E1	MUZ-FH25VE-E1	Type C	CN606
2012	MUZ-FH25VEHZ-E1	MUZ-FH25VEHZ-E1	Type C	CN606
2012	MUZ-FH35VE-E1	MUZ-FH35VE-E1	Type C	CN606
2012	MUZ-FH35VEHZ-E1	MUZ-FH35VEHZ-E1	Type C	CN606
2012	MUZ-FH50VE-E1	MUZ-FH50VE-E1	Type C	CN806
2012	MUZ-FH50VEHZ-E1	MUZ-FH50VEHZ-E1	Type C	CN806
2012	MUZ-GE25VA-E2	MUZ-GE25VA-E2	Type B	CN606
2012	MUZ-GE35VA-E2	MUZ-GE35VA-E2	Type B	CN606
2012	MUZ-GE35VAH-E2	MUZ-GE35VAH-E2	Type B	CN606
2012	MUZ-GF60VE-E1	MUZ-GF60VE-E1	Type C	CN806
2012	MUZ-GF71VE-E1	MUZ-GF71VE-E1	Type C	CN806
2012	MUZ-SF25VE-E1	MUZ-SF25VE-E1	Type C	CN606
2012	MUZ-SF25VEH-E1	MUZ-SF25VEH-E1	Type C	CN606
2012	MUZ-SF35VE-E1	MUZ-SF35VE-E1	Type C	CN606
2012	MUZ-SF35VEH-E1	MUZ-SF35VEH-E1	Type C	CN606
2012	MUZ-SF42VE-E1	MUZ-SF42VE-E1	Type C	CN606
2012	MUZ-SF42VEH-E1	MUZ-SF42VEH-E1	Type C	CN606
2012	MUZ-SF50VE-E1	MUZ-SF50VE-E1	Type C	CN606
2012	MUZ-SF50VEH-E1	MUZ-SF50VEH-E1	Type C	CN606
2012	SUZ-KA25VA3.TH	SUZ-KA25VA3.TH	Type C	CN606
2012	SUZ-KA35VA3.TH	SUZ-KA35VA3.TH	Type C	CN606
2012	SUZ-KA50VA3.TH	SUZ-KA50VA3.TH	Type C	CN606
2012	SUZ-KA60VA3.TH	SUZ-KA60VA3.TH	Type C	CN806
2012	SUZ-KA71VA3.TH	SUZ-KA71VA3.TH	Type C	CN806
2013	MUFZ-KJ25VE-E1	MUFZ-KJ25VE-E1	Type C	CN606
2013	MUFZ-KJ25VEHZ-E1	MUFZ-KJ25VEHZ-E1	Type C	CN606
2013	MUFZ-KJ35VE-E1	MUFZ-KJ35VE-E1	Type C	CN606
2013	MUFZ-KJ35VEHZ-E1	MUFZ-KJ35VEHZ-E1	Type C	CN606
2013	MUFZ-KJ50VE-E1	MUFZ-KJ50VE-E1	Type C	CN806
2013	MUFZ-KJ50VEHZ-E1	MUFZ-KJ50VEHZ-E1	Type C	CN806
2013	MUZ-EF25VE-E2	MUZ-EF25VE-E2	Type C	CN606
2013	MUZ-EF25VEH-E2	MUZ-EF25VEH-E2	Type C	CN606
2013	MUZ-EF35VE-E2	MUZ-EF35VE-E2	Type C	CN606
2013	MUZ-EF35VEH-E2	MUZ-EF35VEH-E2	Type C	CN606
2013	MUZ-EF42VE-E2	MUZ-EF42VE-E2	Type C	CN606
2013	MUZ-EF50VE-E2	MUZ-EF50VE-E2	Type C	CN606

fiscal_year	series	model	Relay cable	Connector
2013	MUZ-HJ25VA-E1	MUZ-HJ25VA-E1	Type C	CN606
2013	MUZ-HJ35VA-E1	MUZ-HJ35VA-E1	Type C	CN606
2013	MUZ-HJ50VA-E1	MUZ-HJ50VA-E1	Type C	CN606
2013	SUHZ-SW45VA.TH	SUHZ-SW45VA.TH	Type C	CN606
2013	SUHZ-SW45VAH.TH	SUHZ-SW45VAH.TH	Type C	CN606
2013	SUZ-KA25VA4.TH	SUZ-KA25VA4.TH	Type C	CN606
2013	SUZ-KA25VA4.TH-ER	SUZ-KA25VA4.TH-ER	Type C	CN606
2013	SUZ-KA35VA4.TH	SUZ-KA35VA4.TH	Type C	CN606
2013	SUZ-KA35VA4.TH-ER	SUZ-KA35VA4.TH-ER	Type C	CN606
2013	SUZ-KA50VA4.TH	SUZ-KA50VA4.TH	Type C	CN606
2013	SUZ-KA50VA4.TH-ER	SUZ-KA50VA4.TH-ER	Type C	CN606
2013	SUZ-KA60VA4.TH	SUZ-KA60VA4.TH	Type C	CN806
2013	SUZ-KA60VA4.TH-ER	SUZ-KA60VA4.TH-ER	Type C	CN806
2013	SUZ-KA71VA4.TH	SUZ-KA71VA4.TH	Type C	CN806
2013	SUZ-KA71VA4.TH-ER	SUZ-KA71VA4.TH-ER	Type C	CN806
2014	MUFZ-KJ25VE-ER1	MUFZ-KJ25VE-ER1	Type C	CN606
2014	MUFZ-KJ25VEHZ-ER1	MUFZ-KJ25VEHZ-ER1	Type C	CN606
2014	MUFZ-KJ35VE-ER1	MUFZ-KJ35VE-ER1	Type C	CN606
2014	MUFZ-KJ35VEHZ-ER1	MUFZ-KJ35VEHZ-ER1	Type C	CN606
2014	MUFZ-KJ50VE-ER1	MUFZ-KJ50VE-ER1	Type C	CN806
2014	MUFZ-KJ50VEHZ-ER1	MUFZ-KJ50VEHZ-ER1	Type C	CN806
2014	MUZ-EF25VE-E3	MUZ-EF25VE-E3	Type C	CN606
2014	MUZ-EF25VE-ER3	MUZ-EF25VE-ER3	Type C	CN606
2014	MUZ-EF25VE-ET4	MUZ-EF25VE-ET4	Type C	CN606
2014	MUZ-EF25VEH-ER2	MUZ-EF25VEH-ER2	Type C	CN606
2014	MUZ-EF25VEH-ET3	MUZ-EF25VEH-ET3	Type C	CN606
2014	MUZ-EF35VE-E3	MUZ-EF35VE-E3	Type C	CN606
2014	MUZ-EF35VE-ER3	MUZ-EF35VE-ER3	Type C	CN606
2014	MUZ-EF35VE-ET4	MUZ-EF35VE-ET4	Type C	CN606
2014	MUZ-EF35VEH-ER2	MUZ-EF35VEH-ER2	Type C	CN606
2014	MUZ-EF35VEH-ET3	MUZ-EF35VEH-ET3	Type C	CN606
2014	MUZ-EF42VE-E3	MUZ-EF42VE-E3	Type C	CN606
2014	MUZ-EF42VE-ER3	MUZ-EF42VE-ER3	Type C	CN606
2014	MUZ-EF42VE-ET4	MUZ-EF42VE-ET4	Type C	CN606
2014	MUZ-EF50VE-ER2	MUZ-EF50VE-ER2	Type C	CN606
2014	MUZ-FH25VE-E2	MUZ-FH25VE-E2	Type C	CN606
2014	MUZ-FH25VE-E3	MUZ-FH25VE-E3	Type C	CN606
2014	MUZ-FH25VE-ER1	MUZ-FH25VE-ER1	Type C	CN606
2014	MUZ-FH25VE-ER2	MUZ-FH25VE-ER2	Type C	CN606
2014	MUZ-FH25VE-ER3	MUZ-FH25VE-ER3	Type C	CN606
2014	MUZ-FH25VEHZ-E3	MUZ-FH25VEHZ-E3	Type C	CN606
2014	MUZ-FH25VEHZ-ER1	MUZ-FH25VEHZ-ER1	Type C	CN606
2014	MUZ-FH25VEHZ-ER3	MUZ-FH25VEHZ-ER3	Type C	CN606
2014	MUZ-FH35VE-E2	MUZ-FH35VE-E2	Type C	CN606
2014	MUZ-FH35VE-ER1	MUZ-FH35VE-ER1	Type C	CN606
2014	MUZ-FH35VE-ER2	MUZ-FH35VE-ER2	Type C	CN606
2014	MUZ-FH35VEHZ-ER1	MUZ-FH35VEHZ-ER1	Type C	CN606
2014	MUZ-FH50VE-ER1	MUZ-FH50VE-ER1	Type C	CN806
2014	MUZ-FH50VEHZ-ER1	MUZ-FH50VEHZ-ER1	Type C	CN806
2014	MUZ-GF60VE-ER1	MUZ-GF60VE-ER1	Type C	CN806
2014	MUZ-GF71VE-ER1	MUZ-GF71VE-ER1	Type C	CN806
2014	MUZ-HJ25VA-ER1	MUZ-HJ25VA-ER1	Type C	CN606
2014	MUZ-HJ35VA-E2	MUZ-HJ35VA-E2	Type B	CN606

fiscal_year	series	model	Relay cable	Connector
2014	MUZ-HJ35VA-ER1	MUZ-HJ35VA-ER1	Type C	CN606
2014	MUZ-HJ35VA-ER2	MUZ-HJ35VA-ER2	Type B	CN606
2014	MUZ-HJ50VA-ER1	MUZ-HJ50VA-ER1	Type C	CN606
2014	MUZ-HJ60VA-E1	MUZ-HJ60VA-E1	Type C	CN606
2014	MUZ-HJ60VA-ER1	MUZ-HJ60VA-ER1	Type C	CN606
2014	MUZ-HJ71VA-E1	MUZ-HJ71VA-E1	Type C	CN606
2014	MUZ-HJ71VA-ER1	MUZ-HJ71VA-ER1	Type C	CN606
2014	MUZ-SF25VE-E2	MUZ-SF25VE-E2	Type C	CN606
2014	MUZ-SF25VE-ER2	MUZ-SF25VE-ER2	Type C	CN606
2014	MUZ-SF25VE-ET3	MUZ-SF25VE-ET3	Type C	CN606
2014	MUZ-SF25VEH-ER1	MUZ-SF25VEH-ER1	Type C	CN606
2014	MUZ-SF25VEH-ET2	MUZ-SF25VEH-ET2	Type C	CN606
2014	MUZ-SF35VE-E2	MUZ-SF35VE-E2	Type C	CN606
2014	MUZ-SF35VE-ER2	MUZ-SF35VE-ER2	Type C	CN606
2014	MUZ-SF35VE-ET3	MUZ-SF35VE-ET3	Type C	CN606
2014	MUZ-SF35VEH-ER1	MUZ-SF35VEH-ER1	Type C	CN606
2014	MUZ-SF35VEH-ET2	MUZ-SF35VEH-ET2	Type C	CN606
2014	MUZ-SF42VE-E2	MUZ-SF42VE-E2	Type C	CN606
2014	MUZ-SF42VE-ER2	MUZ-SF42VE-ER2	Type C	CN606
2014	MUZ-SF42VE-ET3	MUZ-SF42VE-ET3	Type C	CN606
2014	MUZ-SF42VEH-ER1	MUZ-SF42VEH-ER1	Type C	CN606
2014	MUZ-SF42VEH-ET2	MUZ-SF42VEH-ET2	Type C	CN606
2014	MUZ-SF50VE-ER1	MUZ-SF50VE-ER1	Type C	CN606
2014	MUZ-SF50VEH-ER1	MUZ-SF50VEH-ER1	Type C	CN606
2014	MUFZ-KJ25VEHZ-ET1	MUFZ-KJ25VEHZ-ET1	Type C	CN606
2014	MUFZ-KJ35VEHZ-ET1	MUFZ-KJ35VEHZ-ET1	Type C	CN606
2014	MUFZ-KJ50VEHZ-ET1	MUFZ-KJ50VEHZ-ET1	Type C	CN606
2014	MXZ-2D53VAH-ER2	MXZ-2D53VAH-ER2	Type A	CN606
2014	SUZ-SA71VA.TH	SUZ-SA71VA.TH	Type C	CN806
2015	MUZ-DM25VA-E1	MUZ-DM25VA-E1	Type C	CN606
2015	MUZ-DM25VA-ER1	MUZ-DM25VA-ER1	Type C	CN606
2015	MUZ-DM25VA-ET1	MUZ-DM25VA-ET1	Type C	CN606
2015	MUZ-DM35VA-E1	MUZ-DM35VA-E1	Type C	CN606
2015	MUZ-DM35VA-ER1	MUZ-DM35VA-ER1	Type C	CN606
2015	MUZ-DM35VA-ET1	MUZ-DM35VA-ET1	Type C	CN606
2015	MUZ-EF25VE-E4	MUZ-EF25VE-E4	Type C	CN606
2015	MUZ-EF25VE-E5	MUZ-EF25VE-E5	Type C	CN606
2015	MUZ-EF25VE-ER4	MUZ-EF25VE-ER4	Type C	CN606
2015	MUZ-EF25VE-ER5	MUZ-EF25VE-ER5	Type C	CN606
2015	MUZ-EF25VE-ET3	MUZ-EF25VE-ET3	Type C	CN606
2015	MUZ-EF25VE-ET5	MUZ-EF25VE-ET5	Type C	CN606
2015	MUZ-EF25VEH-E3	MUZ-EF25VEH-E3	Type C	CN606
2015	MUZ-EF25VEH-E4	MUZ-EF25VEH-E4	Type C	CN606
2015	MUZ-EF25VEH-ER3	MUZ-EF25VEH-ER3	Type C	CN606
2015	MUZ-EF25VEH-ET2	MUZ-EF25VEH-ET2	Type C	CN606
2015	MUZ-EF35VE-E4	MUZ-EF35VE-E4	Type C	CN606
2015	MUZ-EF35VE-E5	MUZ-EF35VE-E5	Type C	CN606
2015	MUZ-EF35VE-ER4	MUZ-EF35VE-ER4	Type C	CN606
2015	MUZ-EF35VE-ER5	MUZ-EF35VE-ER5	Type C	CN606
2015	MUZ-EF35VE-ET3	MUZ-EF35VE-ET3	Type C	CN606
2015	MUZ-EF35VE-ET5	MUZ-EF35VE-ET5	Type C	CN606
2015	MUZ-EF35VEH-E3	MUZ-EF35VEH-E3	Type C	CN606
2015	MUZ-EF35VEH-E4	MUZ-EF35VEH-E4	Type C	CN606

fiscal_year	series	model	Relay cable	Connector
2015	MUZ-EF35VEH-ER3	MUZ-EF35VEH-ER3	Type C	CN606
2015	MUZ-EF35VEH-ET2	MUZ-EF35VEH-ET2	Type C	CN606
2015	MUZ-EF42VE-E4	MUZ-EF42VE-E4	Type C	CN606
2015	MUZ-EF42VE-E5	MUZ-EF42VE-E5	Type C	CN606
2015	MUZ-EF42VE-ER4	MUZ-EF42VE-ER4	Type C	CN606
2015	MUZ-EF42VE-ER5	MUZ-EF42VE-ER5	Type C	CN606
2015	MUZ-EF42VE-ET3	MUZ-EF42VE-ET3	Type C	CN606
2015	MUZ-EF42VE-ET5	MUZ-EF42VE-ET5	Type C	CN606
2015	MUZ-EF50VE-E3	MUZ-EF50VE-E3	Type C	CN606
2015	MUZ-EF50VE-ER3	MUZ-EF50VE-ER3	Type C	CN606
2015	MUZ-EF50VE-ET2	MUZ-EF50VE-ET2	Type C	CN606
2015	MUZ-EF50VE-ET3	MUZ-EF50VE-ET3	Type C	CN606
2015	MUZ-FH25VE-E4	MUZ-FH25VE-E4	Type C	CN606
2015	MUZ-FH25VE-ER4	MUZ-FH25VE-ER4	Type C	CN606
2015	MUZ-FH25VE-ET2	MUZ-FH25VE-ET2	Type C	CN606
2015	MUZ-FH25VE-ET3	MUZ-FH25VE-ET3	Type C	CN606
2015	MUZ-FH25VEHZ-E4	MUZ-FH25VEHZ-E4	Type C	CN606
2015	MUZ-FH25VEHZ-ER4	MUZ-FH25VEHZ-ER4	Type C	CN606
2015	MUZ-FH25VEHZ-ET1	MUZ-FH25VEHZ-ET1	Type C	CN606
2015	MUZ-FH25VEHZ-ET2	MUZ-FH25VEHZ-ET2	Type C	CN606
2015	MUZ-FH35VE-E3	MUZ-FH35VE-E3	Type C	CN606
2015	MUZ-FH35VE-ER3	MUZ-FH35VE-ER3	Type C	CN606
2015	MUZ-FH35VE-ET2	MUZ-FH35VE-ET2	Type C	CN606
2015	MUZ-FH35VE-ET3	MUZ-FH35VE-ET3	Type C	CN606
2015	MUZ-FH35VEHZ-E2	MUZ-FH35VEHZ-E2	Type C	CN606
2015	MUZ-FH35VEHZ-ER2	MUZ-FH35VEHZ-ER2	Type C	CN606
2015	MUZ-FH35VEHZ-ET1	MUZ-FH35VEHZ-ET1	Type C	CN606
2015	MUZ-FH35VEHZ-ET2	MUZ-FH35VEHZ-ET2	Type C	CN606
2015	MUZ-FH50VE-E2	MUZ-FH50VE-E2	Type C	CN806
2015	MUZ-FH50VE-ER2	MUZ-FH50VE-ER2	Type C	CN806
2015	MUZ-FH50VE-ET1	MUZ-FH50VE-ET1	Type C	CN806
2015	MUZ-FH50VE-ET2	MUZ-FH50VE-ET2	Type C	CN806
2015	MUZ-FH50VEHZ-E2	MUZ-FH50VEHZ-E2	Type C	CN806
2015	MUZ-FH50VEHZ-ER2	MUZ-FH50VEHZ-ER2	Type C	CN806
2015	MUZ-FH50VEHZ-ET1	MUZ-FH50VEHZ-ET1	Type C	CN806
2015	MUZ-FH50VEHZ-ET2	MUZ-FH50VEHZ-ET2	Type C	CN806
2015	MUZ-GF60VE-E2	MUZ-GF60VE-E2	Type C	CN806
2015	MUZ-GF60VE-ER2	MUZ-GF60VE-ER2	Type C	CN806
2015	MUZ-GF60VE-ET1	MUZ-GF60VE-ET1	Type C	CN806
2015	MUZ-GF60VE-ET2	MUZ-GF60VE-ET2	Type C	CN806
2015	MUZ-GF71VE-E2	MUZ-GF71VE-E2	Type C	CN806
2015	MUZ-GF71VE-ER2	MUZ-GF71VE-ER2	Type C	CN806
2015	MUZ-GF71VE-ET1	MUZ-GF71VE-ET1	Type C	CN806
2015	MUZ-GF71VE-ET2	MUZ-GF71VE-ET2	Type C	CN806
2015	MUZ-HJ25VA-E2	MUZ-HJ25VA-E2	Type C	CN606
2015	MUZ-HJ25VA-ER2	MUZ-HJ25VA-ER2	Type C	CN606
2015	MUZ-HJ25VA-ET1	MUZ-HJ25VA-ET1	Type C	CN606
2015	MUZ-HJ25VA-ET2	MUZ-HJ25VA-ET2	Type C	CN606
2015	MUZ-HJ35VA-E3	MUZ-HJ35VA-E3	Type C	CN606
2015	MUZ-HJ35VA-ER3	MUZ-HJ35VA-ER3	Type C	CN606
2015	MUZ-HJ35VA-ET1	MUZ-HJ35VA-ET1	Type C	CN606
2015	MUZ-HJ35VA-ET2	MUZ-HJ35VA-ET2	Type C	CN606
2015	MUZ-HJ50VA-E2	MUZ-HJ50VA-E2	Type C	CN606

fiscal_year	series	model	Relay cable	Connector
2015	MUZ-HJ50VA-ER2	MUZ-HJ50VA-ER2	Type C	CN606
2015	MUZ-HJ50VA-ET1	MUZ-HJ50VA-ET1	Type C	CN606
2015	MUZ-HJ50VA-ET2	MUZ-HJ50VA-ET2	Type C	CN606
2015	MUZ-HJ60VA-E1	MUZ-HJ60VA-E1	Type C	CN606
2015	MUZ-HJ60VA-E2	MUZ-HJ60VA-E2	Type C	CN606
2015	MUZ-HJ60VA-ER1	MUZ-HJ60VA-ER1	Type C	CN606
2015	MUZ-HJ60VA-ET1	MUZ-HJ60VA-ET1	Type C	CN606
2015	MUZ-HJ71VA-E1	MUZ-HJ71VA-E1	Type C	CN606
2015	MUZ-HJ71VA-E2	MUZ-HJ71VA-E2	Type C	CN606
2015	MUZ-HJ71VA-ER1	MUZ-HJ71VA-ER1	Type C	CN606
2015	MUZ-HJ71VA-ET1	MUZ-HJ71VA-ET1	Type C	CN606
2015	MUZ-SF25VE-E3	MUZ-SF25VE-E3	Type C	CN606
2015	MUZ-SF25VE-E4	MUZ-SF25VE-E4	Type C	CN606
2015	MUZ-SF25VE-ER3	MUZ-SF25VE-ER3	Type C	CN606
2015	MUZ-SF25VE-ER4	MUZ-SF25VE-ER4	Type C	CN606
2015	MUZ-SF25VE-ET2	MUZ-SF25VE-ET2	Type C	CN606
2015	MUZ-SF25VE-ET4	MUZ-SF25VE-ET4	Type C	CN606
2015	MUZ-SF25VEH-E2	MUZ-SF25VEH-E2	Type C	CN606
2015	MUZ-SF25VEH-E3	MUZ-SF25VEH-E3	Type C	CN606
2015	MUZ-SF25VEH-ER2	MUZ-SF25VEH-ER2	Type C	CN606
2015	MUZ-SF25VEH-ET1	MUZ-SF25VEH-ET1	Type C	CN606
2015	MUZ-SF35VE-E3	MUZ-SF35VE-E3	Type C	CN606
2015	MUZ-SF35VE-E4	MUZ-SF35VE-E4	Type C	CN606
2015	MUZ-SF35VE-ER3	MUZ-SF35VE-ER3	Type C	CN606
2015	MUZ-SF35VE-ER4	MUZ-SF35VE-ER4	Type C	CN606
2015	MUZ-SF35VE-ET2	MUZ-SF35VE-ET2	Type C	CN606
2015	MUZ-SF35VE-ET4	MUZ-SF35VE-ET4	Type C	CN606
2015	MUZ-SF35VEH-E2	MUZ-SF35VEH-E2	Type C	CN606
2015	MUZ-SF35VEH-E3	MUZ-SF35VEH-E3	Type C	CN606
2015	MUZ-SF35VEH-ER2	MUZ-SF35VEH-ER2	Type C	CN606
2015	MUZ-SF35VEH-ET1	MUZ-SF35VEH-ET1	Type C	CN606
2015	MUZ-SF42VE-E3	MUZ-SF42VE-E3	Type C	CN606
2015	MUZ-SF42VE-E4	MUZ-SF42VE-E4	Type C	CN606
2015	MUZ-SF42VE-ER3	MUZ-SF42VE-ER3	Type C	CN606
2015	MUZ-SF42VE-ER4	MUZ-SF42VE-ER4	Type C	CN606
2015	MUZ-SF42VE-ET2	MUZ-SF42VE-ET2	Type C	CN606
2015	MUZ-SF42VE-ET4	MUZ-SF42VE-ET4	Type C	CN606
2015	MUZ-SF42VEH-E2	MUZ-SF42VEH-E2	Type C	CN606
2015	MUZ-SF42VEH-E3	MUZ-SF42VEH-E3	Type C	CN606
2015	MUZ-SF42VEH-ER2	MUZ-SF42VEH-ER2	Type C	CN606
2015	MUZ-SF42VEH-ET1	MUZ-SF42VEH-ET1	Type C	CN606
2015	MUZ-SF50VE-E2	MUZ-SF50VE-E2	Type C	CN606
2015	MUZ-SF50VE-ER2	MUZ-SF50VE-ER2	Type C	CN606
2015	MUZ-SF50VE-ET1	MUZ-SF50VE-ET1	Type C	CN606
2015	MUZ-SF50VE-ET2	MUZ-SF50VE-ET2	Type C	CN606
2015	MUZ-SF50VEH-E2	MUZ-SF50VEH-E2	Type C	CN606
2015	MUZ-SF50VEH-ET1	MUZ-SF50VEH-ET1	Type C	CN606
2015	MXZ-2B30VA-E1	MXZ-2B30VA-E1	Type AD	CN606
2015	MXZ-2B40VA-E1	MXZ-2B40VA-E1	Type AD	CN606
2015	MXZ-2B52VA-E1	MXZ-2B52VA-E1	Type AD	CN606
2015	MXZ-2C30VA-E1	MXZ-2C30VA-E1	Type AD	CN606
2015	MXZ-2C40VA-E1	MXZ-2C40VA-E1	Type AD	CN606
2015	MXZ-2C52VA-E1	MXZ-2C52VA-E1	Type AD	CN606

fiscal_year	series	model	Relay cable	Connector
2015	MXZ-2D33VA-E1	MXZ-2D33VA-E1	Type AD	CN606
2015	MXZ-2D33VA-E2	MXZ-2D33VA-E2	Type AD	CN606
2015	MXZ-2D33VA-ER2	MXZ-2D33VA-ER2	Type AD	CN606
2015	MXZ-2D33VA-ET2	MXZ-2D33VA-ET2	Type AD	CN606
2015	MXZ-2D40VA-E1	MXZ-2D40VA-E1	Type AD	CN606
2015	MXZ-2D40VA-ER2	MXZ-2D40VA-ER2	Type AD	CN606
2015	MXZ-2D42VA2-E3	MXZ-2D42VA2-E3	Type AD	CN606
2015	MXZ-2D42VA2-ER3	MXZ-2D42VA2-ER3	Type AD	CN606
2015	MXZ-2D42VA2-ET3	MXZ-2D42VA2-ET3	Type AD	CN606
2015	MXZ-2D42VA-E2	MXZ-2D42VA-E2	Type AD	CN606
2015	MXZ-2D42VA-E3	MXZ-2D42VA-E3	Type AD	CN606
2015	MXZ-2D42VA-ER3	MXZ-2D42VA-ER3	Type AD	CN606
2015	MXZ-2D42VA-ET2	MXZ-2D42VA-ET2	Type AD	CN606
2015	MXZ-2D42VA-ET3	MXZ-2D42VA-ET3	Type AD	CN606
2015	MXZ-2D53VA2-E3	MXZ-2D53VA2-E3	Type AD	CN606
2015	MXZ-2D53VA2-ER3	MXZ-2D53VA2-ER3	Type AD	CN606
2015	MXZ-2D53VA2-ET3	MXZ-2D53VA2-ET3	Type AD	CN606
2015	MXZ-2D53VA-E1	MXZ-2D53VA-E1	Type AD	CN606
2015	MXZ-2D53VA-E2	MXZ-2D53VA-E2	Type AD	CN606
2015	MXZ-2D53VA-E3	MXZ-2D53VA-E3	Type AD	CN606
2015	MXZ-2D53VA-ER2	MXZ-2D53VA-ER2	Type AD	CN606
2015	MXZ-2D53VA-ER3	MXZ-2D53VA-ER3	Type AD	CN606
2015	MXZ-2D53VA-ET2	MXZ-2D53VA-ET2	Type AD	CN606
2015	MXZ-2D53VA-ET3	MXZ-2D53VA-ET3	Type AD	CN606
2015	MXZ-2D53VAH2-E3	MXZ-2D53VAH2-E3	Type AD	CN606
2015	MXZ-2D53VAH-E1	MXZ-2D53VAH-E1	Type AD	CN606
2015	MXZ-2D53VAH-E2	MXZ-2D53VAH-E2	Type AD	CN606
2015	MXZ-2D53VAH-E3	MXZ-2D53VAH-E3	Type AD	CN606
2015	MXZ-2DM40VA-E1	MXZ-2DM40VA-E1	Type AD	CN606
2015	MXZ-2DM40VA-ER1	MXZ-2DM40VA-ER1	Type AD	CN606
2015	MXZ-2DM40VA-ET1	MXZ-2DM40VA-ET1	Type AD	CN606
2015	MXZ-2E53VAHZ-E1	MXZ-2E53VAHZ-E1	Type C	CN861
2015	MXZ-2E53VAHZ-ER1	MXZ-2E53VAHZ-ER1	Type C	CN861
2015	MXZ-2HJ40VA-E1	MXZ-2HJ40VA-E1	Type AD	CN606
2015	MXZ-2HJ40VA-ER1	MXZ-2HJ40VA-ER1	Type AD	CN606
2015	MXZ-2HJ40VA-ET1	MXZ-2HJ40VA-ET1	Type AD	CN606
2015	MXZ-3B54VA-E1	MXZ-3B54VA-E1	Type AD	CN605
2015	MXZ-3B68VA-E1	MXZ-3B68VA-E1	Type AD	CN605
2015	MXZ-3C54VA-E1	MXZ-3C54VA-E1	Type AD	CN605
2015	MXZ-3C68VA-E1	MXZ-3C68VA-E1	Type AD	CN605
2015	MXZ-3D54VA2-E2	MXZ-3D54VA2-E2	Type C	CN861
2015	MXZ-3D54VA2-E3	MXZ-3D54VA2-E3	Type C	CN861
2015	MXZ-3D54VA2-ER2	MXZ-3D54VA2-ER2	Type C	CN861
2015	MXZ-3D54VA2-ER3	MXZ-3D54VA2-ER3	Type C	CN861
2015	MXZ-3D54VA2-ET2	MXZ-3D54VA2-ET2	Type C	CN861
2015	MXZ-3D54VA2-ET3	MXZ-3D54VA2-ET3	Type C	CN861
2015	MXZ-3D54VA-E1	MXZ-3D54VA-E1	Type C	CN861
2015	MXZ-3D68VA-E1	MXZ-3D68VA-E1	Type C	CN861
2015	MXZ-3D68VA-E2	MXZ-3D68VA-E2	Type C	CN861
2015	MXZ-3D68VA-E3	MXZ-3D68VA-E3	Type C	CN861
2015	MXZ-3D68VA-ER2	MXZ-3D68VA-ER2	Type C	CN861
2015	MXZ-3D68VA-ER3	MXZ-3D68VA-ER3	Type C	CN861
2015	MXZ-3D68VA-ET2	MXZ-3D68VA-ET2	Type C	CN861

fiscal_year	series	model	Relay cable	Connector
2015	MXZ-3D68VA-ET3	MXZ-3D68VA-ET3	Type C	CN861
2015	MXZ-3DM50VA-E1	MXZ-3DM50VA-E1	Type C	CN861
2015	MXZ-3DM50VA-ER1	MXZ-3DM50VA-ER1	Type C	CN861
2015	MXZ-3DM50VA-ET1	MXZ-3DM50VA-ET1	Type C	CN861
2015	MXZ-3E54VA-E1	MXZ-3E54VA-E1	Type C	CN861
2015	MXZ-3E54VA-ER1	MXZ-3E54VA-ER1	Type C	CN861
2015	MXZ-3E54VA-ET1	MXZ-3E54VA-ET1	Type C	CN861
2015	MXZ-3E68VA-E1	MXZ-3E68VA-E1	Type C	CN861
2015	MXZ-3E68VA-ER1	MXZ-3E68VA-ER1	Type C	CN861
2015	MXZ-3E68VA-ET1	MXZ-3E68VA-ET1	Type C	CN861
2015	MXZ-3HJ50VA-E1	MXZ-3HJ50VA-E1	Type C	CN861
2015	MXZ-3HJ50VA-ER1	MXZ-3HJ50VA-ER1	Type C	CN861
2015	MXZ-3HJ50VA-ET1	MXZ-3HJ50VA-ET1	Type C	CN861
2015	MXZ-4B71VA-E1	MXZ-4B71VA-E1	Type AD	CN605
2015	MXZ-4B80VA-E1	MXZ-4B80VA-E1	Type AD	CN605
2015	MXZ-4C71VA-E1	MXZ-4C71VA-E1	Type AD	CN605
2015	MXZ-4C80VA2-E1	MXZ-4C80VA2-E1	Type C	CN605
2015	MXZ-4C80VA-E1 (a)	MXZ-4C80VA-E1 (a)	Type AD	CN605
2015	MXZ-4C80VA-E1 (b)	MXZ-4C80VA-E1 (b)	Type C	CN605
2015	MXZ-4D72VA-E1	MXZ-4D72VA-E1	Type C	CN861
2015	MXZ-4D72VA-E2	MXZ-4D72VA-E2	Type C	CN861
2015	MXZ-4D72VA-E3	MXZ-4D72VA-E3	Type C	CN861
2015	MXZ-4D72VA-ER2	MXZ-4D72VA-ER2	Type C	CN861
2015	MXZ-4D72VA-ER3	MXZ-4D72VA-ER3	Type C	CN861
2015	MXZ-4D72VA-ET2	MXZ-4D72VA-ET2	Type C	CN861
2015	MXZ-4D72VA-ET3	MXZ-4D72VA-ET3	Type C	CN861
2015	MXZ-4D83VA-E1	MXZ-4D83VA-E1	Type C	CN605
2015	MXZ-4D83VA-E2	MXZ-4D83VA-E2	Type C	CN605
2015	MXZ-4D83VA-ER2	MXZ-4D83VA-ER2	Type C	CN605
2015	MXZ-4D83VA-ET2	MXZ-4D83VA-ET2	Type C	CN605
2015	MXZ-4E72VA-E1	MXZ-4E72VA-E1	Type C	CN861
2015	MXZ-4E72VA-ER1	MXZ-4E72VA-ER1	Type C	CN861
2015	MXZ-4E72VA-ET1	MXZ-4E72VA-ET1	Type C	CN861
2015	MXZ-4E83VA-E1	MXZ-4E83VA-E1	Type C	CN861
2015	MXZ-4E83VA-E2	MXZ-4E83VA-E2	Type C	CN861
2015	MXZ-4E83VA-ER1	MXZ-4E83VA-ER1	Type C	CN861
2015	MXZ-4E83VA-ET1	MXZ-4E83VA-ET1	Type C	CN861
2015	MXZ-4E83VA-ET2	MXZ-4E83VA-ET2	Type C	CN861
2015	MXZ-4E83VAHZ-E1	MXZ-4E83VAHZ-E1	Type C	CN861
2015	MXZ-4E83VAHZ-ER1	MXZ-4E83VAHZ-ER1	Type C	CN861
2015	MXZ-5B100VA-E1	MXZ-5B100VA-E1	Type AD	CN605
2015	MXZ-5C100VA2-E1	MXZ-5C100VA2-E1	Type C	CN605
2015	MXZ-5C100VA-E1 (a)	MXZ-5C100VA-E1 (a)	Type AD	CN605
2015	MXZ-5C100VA-E1 (b)	MXZ-5C100VA-E1 (b)	Type C	CN605
2015	MXZ-5D102VA-E1	MXZ-5D102VA-E1	Type C	CN605
2015	MXZ-5D102VA-E2	MXZ-5D102VA-E2	Type C	CN605
2015	MXZ-5D102VA-ER2	MXZ-5D102VA-ER2	Type C	CN605
2015	MXZ-5D102VA-ET2	MXZ-5D102VA-ET2	Type C	CN605
2015	MXZ-5E102VA-E1	MXZ-5E102VA-E1	Type C	CN861
2015	MXZ-5E102VA-E2	MXZ-5E102VA-E2	Type C	CN861
2015	MXZ-5E102VA-ER1	MXZ-5E102VA-ER1	Type C	CN861
2015	MXZ-5E102VA-ET1	MXZ-5E102VA-ET1	Type C	CN861
2015	MXZ-5E102VA-ET2	MXZ-5E102VA-ET2	Type C	CN861

fiscal_year	series	model	Relay cable	Connector
2015	MXZ-6C120VA-E1	MXZ-6C120VA-E1	Type C	CN861
2015	MXZ-6C120VA-E2	MXZ-6C120VA-E2	Type C	CN861
2015	MXZ-6C122VA-E1	MXZ-6C122VA-E1	Type C	CN861
2015	MXZ-6C122VA-E2	MXZ-6C122VA-E2	Type C	CN861
2015	MXZ-6C122VA-ER1	MXZ-6C122VA-ER1	Type C	CN861
2015	MXZ-6C122VA-ER2	MXZ-6C122VA-ER2	Type C	CN861
2015	MXZ-6D122VA-E1	MXZ-6D122VA-E1	Type C	CN861
2015	MXZ-6D122VA-ER1	MXZ-6D122VA-ER1	Type C	CN861
2015	MXZ-6D122VA-ET1	MXZ-6D122VA-ET1	Type C	CN861
2015	MXZ-2D53VAH-ER3	MXZ-2D53VAH-ER3	Type A	CN606
2016	MUZ-DM50VA-ER1	MUZ-DM50VA-ER1	Type C	CN606
2016	MUZ-DM60VA-ER1	MUZ-DM60VA-ER1	Type C	CN606
2016	MUZ-DM71VA-ER1	MUZ-DM71VA-ER1	Type C	CN606
2016	MUZ-HC35VA-E1	MUZ-HC35VA-E1	Type B	CN606
2016	MUZ-LN25VG-E1	MUZ-LN25VG-E1	Type C	CN606
2016	MUZ-LN25VG-ER1	MUZ-LN25VG-ER1	Type C	CN606
2016	MUZ-LN25VG-ET1	MUZ-LN25VG-ET1	Type C	CN606
2016	MUZ-LN25VGHZ-E1	MUZ-LN25VGHZ-E1	Type C	CN606
2016	MUZ-LN25VGHZ-ER1	MUZ-LN25VGHZ-ER1	Type C	CN606
2016	MUZ-LN25VGHZ-ET1	MUZ-LN25VGHZ-ET1	Type C	CN606
2016	MUZ-LN35VG-E1	MUZ-LN35VG-E1	Type C	CN606
2016	MUZ-LN35VG-ER1	MUZ-LN35VG-ER1	Type C	CN606
2016	MUZ-LN35VG-ET1	MUZ-LN35VG-ET1	Type C	CN606
2016	MUZ-LN35VGHZ-E1	MUZ-LN35VGHZ-E1	Type C	CN606
2016	MUZ-LN35VGHZ-ER1	MUZ-LN35VGHZ-ER1	Type C	CN606
2016	MUZ-LN35VGHZ-ET1	MUZ-LN35VGHZ-ET1	Type C	CN606
2016	MUZ-LN50VG-E1	MUZ-LN50VG-E1	Type C	CN606
2016	MUZ-LN50VG-ER1	MUZ-LN50VG-ER1	Type C	CN606
2016	MUZ-LN50VG-ET1	MUZ-LN50VG-ET1	Type C	CN606
2016	MUZ-LN50VGHZ-E1	MUZ-LN50VGHZ-E1	Type C	CN606
2016	MUZ-LN50VGHZ-ER1	MUZ-LN50VGHZ-ER1	Type C	CN606
2016	MUZ-LN50VGHZ-ET1	MUZ-LN50VGHZ-ET1	Type C	CN606
2016	MUZ-LN60VG-E1	MUZ-LN60VG-E1	Type C	CN606
2016	MUZ-LN60VG-ER1	MUZ-LN60VG-ER1	Type C	CN606
2016	MUZ-LN60VG-ET1	MUZ-LN60VG-ET1	Type C	CN606
2016	MUZ-WN25VA-E1	MUZ-WN25VA-E1	Type C	CN606
2016	MUZ-WN25VA-ER1	MUZ-WN25VA-ER1	Type C	CN606
2016	MUZ-WN25VA-ET1	MUZ-WN25VA-ET1	Type C	CN606
2016	MUZ-WN35VA-ET1	MUZ-WN35VA-ET1	Type C	CN606
2016	MXZ-4E83VA-E3	MXZ-4E83VA-E3	Type C	CN861
2016	MXZ-4E83VA-ER2	MXZ-4E83VA-ER2	Type C	CN861
2016	MXZ-4E83VA-ET3	MXZ-4E83VA-ET3	Type C	CN861
2016	MXZ-4E83VAHZ-E2	MXZ-4E83VAHZ-E2	Type C	CN861
2016	MXZ-4E83VAHZ-ER2	MXZ-4E83VAHZ-ER2	Type C	CN861
2016	MXZ-5E102VA-E3	MXZ-5E102VA-E3	Type C	CN861
2016	MXZ-5E102VA-ER2	MXZ-5E102VA-ER2	Type C	CN861
2016	MXZ-5E102VA-ET3	MXZ-5E102VA-ET3	Type C	CN861
2016	MXZ-6D122VA-E2	MXZ-6D122VA-E2	Type C	CN861
2016	MXZ-6D122VA-ER2	MXZ-6D122VA-ER2	Type C	CN861
2016	MXZ-6D122VA-ET2	MXZ-6D122VA-ET2	Type C	CN861
2016	MUFZ-KJ25VEHZ-E2	MUFZ-KJ25VEHZ-E2	Type C	CN606
2016	MUFZ-KJ25VEHZ-ER2	MUFZ-KJ25VEHZ-ER2	Type C	CN606
2016	MUFZ-KJ25VEHZ-ET2	MUFZ-KJ25VEHZ-ET2	Type C	CN606

fiscal_year	series	model	Relay cable	Connector
2016	MUFZ-KJ35VEHZ-E2	MUFZ-KJ35VEHZ-E2	Type C	CN606
2016	MUFZ-KJ35VEHZ-ER2	MUFZ-KJ35VEHZ-ER2	Type C	CN606
2016	MUFZ-KJ35VEHZ-ET2	MUFZ-KJ35VEHZ-ET2	Type C	CN606
2016	MUFZ-KJ50VEHZ-E2	MUFZ-KJ50VEHZ-E2	Type C	CN606
2016	MUFZ-KJ50VEHZ-ER2	MUFZ-KJ50VEHZ-ER2	Type C	CN606
2016	MUFZ-KJ50VEHZ-ET2	MUFZ-KJ50VEHZ-ET2	Type C	CN606
2016	SUZ-KA25VA6.TH	SUZ-KA25VA6.TH	Type C	CN606
2016	SUZ-KA25VA6.TH-ER	SUZ-KA25VA6.TH-ER	Type C	CN606
2016	SUZ-KA25VA6.TH-ET	SUZ-KA25VA6.TH-ET	Type C	CN606
2016	SUZ-KA35VA6.TH	SUZ-KA35VA6.TH	Type C	CN606
2016	SUZ-KA35VA6.TH-ER	SUZ-KA35VA6.TH-ER	Type C	CN606
2016	SUZ-KA35VA6.TH-ET	SUZ-KA35VA6.TH-ET	Type C	CN606
2016	SUZ-KA50VA6.TH	SUZ-KA50VA6.TH	Type C	CN606
2016	SUZ-KA50VA6.TH-ET	SUZ-KA50VA6.TH-ET	Type C	CN606
2016	SUZ-KA60VA6.TH	SUZ-KA60VA6.TH	Type C	CN806
2016	SUZ-KA60VA6.TH-ET	SUZ-KA60VA6.TH-ET	Type C	CN806
2016	SUZ-KA71VA6.TH	SUZ-KA71VA6.TH	Type C	CN806
2016	SUZ-KA71VA6.TH-ET	SUZ-KA71VA6.TH-ET	Type C	CN806
2017	MUZ-WN35VA-E1	MUZ-WN35VA-E1	Type C	CN606
2017	MXZ-2D33VA-E3	MXZ-2D33VA-E3	Type AD	CN606
2017	MXZ-2D33VA-ER3	MXZ-2D33VA-ER3	Type AD	CN606
2017	MXZ-2D33VA-ET3	MXZ-2D33VA-ET3	Type AD	CN606
2017	MXZ-4D83VA-ER1	MXZ-4D83VA-ER1	Type C	CN605
2017	MXZ-5D102VA-ER1	MXZ-5D102VA-ER1	Type C	CN605
2017	MXZ-6D122VA2-E1	MXZ-6D122VA2-E1	Type C	CN861
2017	MXZ-6D122VA2-ER1	MXZ-6D122VA2-ER1	Type C	CN861
2017	MXZ-6D122VA2-ET1	MXZ-6D122VA2-ET1	Type C	CN861
2018	MUY-TP35VF-E1	MUY-TP35VF-E1	Type C	CN606
2018	MUY-TP35VF-ET1	MUY-TP35VF-ET1	Type C	CN606
2018	MUY-TP50VF-E1	MUY-TP50VF-E1	Type C	CN606
2018	MUY-TP50VF-ET1	MUY-TP50VF-ET1	Type C	CN606
2018	MUZ-AP25VG-E1	MUZ-AP25VG-E1	Type C	CN606
2018	MUZ-AP25VG-E6	MUZ-AP25VG-E6	Type C	CN606
2018	MUZ-AP25VG-ER1	MUZ-AP25VG-ER1	Type C	CN606
2018	MUZ-AP25VG-ET1	MUZ-AP25VG-ET1	Type C	CN606
2018	MUZ-AP25VGH-E1	MUZ-AP25VGH-E1	Type C	CN606
2018	MUZ-AP35VG-E1	MUZ-AP35VG-E1	Type C	CN606
2018	MUZ-AP35VG-E6	MUZ-AP35VG-E6	Type C	CN606
2018	MUZ-AP35VG-ER1	MUZ-AP35VG-ER1	Type C	CN606
2018	MUZ-AP35VG-ET1	MUZ-AP35VG-ET1	Type C	CN606
2018	MUZ-AP35VGH-E1	MUZ-AP35VGH-E1	Type C	CN606
2018	MUZ-AP42VG-E1	MUZ-AP42VG-E1	Type C	CN606
2018	MUZ-AP42VG-E6	MUZ-AP42VG-E6	Type C	CN606
2018	MUZ-AP42VG-ER1	MUZ-AP42VG-ER1	Type C	CN606
2018	MUZ-AP42VG-ET1	MUZ-AP42VG-ET1	Type C	CN606
2018	MUZ-AP42VGH-E1	MUZ-AP42VGH-E1	Type C	CN606
2018	MUZ-AP50VG-E1	MUZ-AP50VG-E1	Type C	CN606
2018	MUZ-AP50VG-ER1	MUZ-AP50VG-ER1	Type C	CN606
2018	MUZ-AP50VG-ET1	MUZ-AP50VG-ET1	Type C	CN606
2018	MUZ-AP50VGH-E1	MUZ-AP50VGH-E1	Type C	CN606
2018	MUZ-AP25VG-E2	MUZ-AP25VG-E2	Type C	CN606
2018	MUZ-AP25VG-ER2	MUZ-AP25VG-ER2	Type C	CN606
2018	MUZ-AP25VG-ET2	MUZ-AP25VG-ET2	Type C	CN606

fiscal_year	series	model	Relay cable	Connector
2018	MUZ-AP25VGH-E2	MUZ-AP25VGH-E2	Type C	CN606
2018	MUZ-AP35VG-E2	MUZ-AP35VG-E2	Type C	CN606
2018	MUZ-AP35VG-ER2	MUZ-AP35VG-ER2	Type C	CN606
2018	MUZ-AP35VG-ET2	MUZ-AP35VG-ET2	Type C	CN606
2018	MUZ-AP35VGH-E2	MUZ-AP35VGH-E2	Type C	CN606
2018	MUZ-AP42VG-E2	MUZ-AP42VG-E2	Type C	CN606
2018	MUZ-AP42VG-ER2	MUZ-AP42VG-ER2	Type C	CN606
2018	MUZ-AP42VG-ET2	MUZ-AP42VG-ET2	Type C	CN606
2018	MUZ-AP42VGH-E2	MUZ-AP42VGH-E2	Type C	CN606
2018	MUZ-HR25VF-ET1	MUZ-HR25VF-ET1	Type C	CN606
2018	MUZ-HR35VF-ET1	MUZ-HR35VF-ET1	Type C	CN606
2018	MUZ-HR42VF-ET1	MUZ-HR42VF-ET1	Type C	CN606
2018	MUZ-HR50VF-ET1	MUZ-HR50VF-ET1	Type C	CN606
2018	MXZ-2D33VA-E4	MXZ-2D33VA-E4	Type A	CN606
2018	MXZ-2D33VA-ER4	MXZ-2D33VA-ER4	Type A	CN606
2018	MXZ-2D33VA-ET4	MXZ-2D33VA-ET4	Type A	CN606
2018	MXZ-2D42VA2-E4	MXZ-2D42VA2-E4	Type A	CN606
2018	MXZ-2D42VA2-ER4	MXZ-2D42VA2-ER4	Type A	CN606
2018	MXZ-2D42VA2-ET4	MXZ-2D42VA2-ET4	Type A	CN606
2018	MXZ-2D53VA2-E4	MXZ-2D53VA2-E4	Type A	CN606
2018	MXZ-2D53VA2-ER4	MXZ-2D53VA2-ER4	Type A	CN606
2018	MXZ-2D53VA2-ET4	MXZ-2D53VA2-ET4	Type A	CN606
2018	MXZ-2D53VAH2-E4	MXZ-2D53VAH2-E4	Type A	CN606
2018	MXZ-2E53VAHZ-E2	MXZ-2E53VAHZ-E2	Type C	CN861
2018	MXZ-2E53VAHZ-ER2	MXZ-2E53VAHZ-ER2	Type C	CN861
2018	MXZ-2F33VF2-E1	MXZ-2F33VF2-E1	Type C	CN606
2018	MXZ-2F33VF2-ET1	MXZ-2F33VF2-ET1	Type C	CN606
2018	MXZ-2F33VF3-E1	MXZ-2F33VF3-E1	Type C	CN606
2018	MXZ-2F33VF3-ET1	MXZ-2F33VF3-ET1	Type C	CN606
2018	MXZ-2F33VF-E1	MXZ-2F33VF-E1	Type C	CN606
2018	MXZ-2F33VF-ET1	MXZ-2F33VF-ET1	Type C	CN606
2018	MXZ-2F42VF2-ET1	MXZ-2F42VF2-ET1	Type C	CN606
2018	MXZ-2F42VF3-E1	MXZ-2F42VF3-E1	Type C	CN606
2018	MXZ-2F42VF3-ET1	MXZ-2F42VF3-ET1	Type C	CN606
2018	MXZ-2F42VF-E1	MXZ-2F42VF-E1	Type C	CN606
2018	MXZ-2F42VF-ET1	MXZ-2F42VF-ET1	Type C	CN606
2018	MXZ-2F53VF2-ET1	MXZ-2F53VF2-ET1	Type C	CN606
2018	MXZ-2F53VF3-E1	MXZ-2F53VF3-E1	Type C	CN606
2018	MXZ-2F53VF3-ET1	MXZ-2F53VF3-ET1	Type C	CN606
2018	MXZ-2F53VF-E1	MXZ-2F53VF-E1	Type C	CN606
2018	MXZ-2F53VF-ET1	MXZ-2F53VF-ET1	Type C	CN606
2018	MXZ-2F53VFH-E1	MXZ-2F53VFH-E1	Type C	CN606
2018	MXZ-2HA40VF-E1	MXZ-2HA40VF-E1	Type C	CN606
2018	MXZ-2HA40VF-ET1	MXZ-2HA40VF-ET1	Type C	CN606
2018	MXZ-2HA50VF-E1	MXZ-2HA50VF-E1	Type C	CN606
2018	MXZ-2HA50VF-ET1	MXZ-2HA50VF-ET1	Type C	CN606
2018	MXZ-3E54VA-E2	MXZ-3E54VA-E2	Type C	CN861
2018	MXZ-3E54VA-ER2	MXZ-3E54VA-ER2	Type C	CN861
2018	MXZ-3E54VA-ET2	MXZ-3E54VA-ET2	Type C	CN861
2018	MXZ-3E68VA-E2	MXZ-3E68VA-E2	Type C	CN861
2018	MXZ-3E68VA-ER2	MXZ-3E68VA-ER2	Type C	CN861
2018	MXZ-3E68VA-ET2	MXZ-3E68VA-ET2	Type C	CN861
2018	MXZ-3F54VF-E1	MXZ-3F54VF-E1	Type C	CN861

fiscal_year	series	model	Relay cable	Connector
2018	MXZ-3F54VF-E2	MXZ-3F54VF-E2	Type C	CN861
2018	MXZ-3F54VF-ET1	MXZ-3F54VF-ET1	Type C	CN861
2018	MXZ-3F54VF-ET2	MXZ-3F54VF-ET2	Type C	CN861
2018	MXZ-3F68VF-E1	MXZ-3F68VF-E1	Type C	CN861
2018	MXZ-3F68VF-E2	MXZ-3F68VF-E2	Type C	CN861
2018	MXZ-3F68VF-ET1	MXZ-3F68VF-ET1	Type C	CN861
2018	MXZ-3F68VF-ET2	MXZ-3F68VF-ET2	Type C	CN861
2018	MXZ-3HA50VF-E1	MXZ-3HA50VF-E1	Type C	CN861
2018	MXZ-3HA50VF-ET1	MXZ-3HA50VF-ET1	Type C	CN861
2018	MXZ-4E72VA-E2	MXZ-4E72VA-E2	Type C	CN861
2018	MXZ-4E72VA-ER2	MXZ-4E72VA-ER2	Type C	CN861
2018	MXZ-4E72VA-ET2	MXZ-4E72VA-ET2	Type C	CN861
2018	MXZ-4E83VA-E4	MXZ-4E83VA-E4	Type C	CN861
2018	MXZ-4E83VA-ER3	MXZ-4E83VA-ER3	Type C	CN861
2018	MXZ-4E83VA-ET4	MXZ-4E83VA-ET4	Type C	CN861
2018	MXZ-4E83VAHZ-E3	MXZ-4E83VAHZ-E3	Type C	CN861
2018	MXZ-4E83VAHZ-ER3	MXZ-4E83VAHZ-ER3	Type C	CN861
2018	MXZ-4F72VF-E1	MXZ-4F72VF-E1	Type C	CN861
2018	MXZ-4F72VF-E2	MXZ-4F72VF-E2	Type C	CN861
2018	MXZ-4F72VF-ET1	MXZ-4F72VF-ET1	Type C	CN861
2018	MXZ-4F72VF-ET2	MXZ-4F72VF-ET2	Type C	CN861
2018	MXZ-5E102VA-E4	MXZ-5E102VA-E4	Type C	CN861
2018	MXZ-5E102VA-ER3	MXZ-5E102VA-ER3	Type C	CN861
2018	MXZ-5E102VA-ET4	MXZ-5E102VA-ET4	Type C	CN861
2018	SUZ-M25VA.TH	SUZ-M25VA.TH	Type C	CN606
2018	SUZ-M25VA-ET.TH	SUZ-M25VA-ET.TH	Type C	CN606
2018	SUZ-M35VA.TH	SUZ-M35VA.TH	Type C	CN606
2018	SUZ-M35VA-ET.TH	SUZ-M35VA-ET.TH	Type C	CN606
2018	SUZ-M50VA.TH	SUZ-M50VA.TH	Type C	CN606
2018	SUZ-M50VA-ET.TH	SUZ-M50VA-ET.TH	Type C	CN606
2018	SUZ-M60VA.TH	SUZ-M60VA.TH	Type C	CN806
2018	SUZ-M60VA-ET.TH	SUZ-M60VA-ET.TH	Type C	CN806
2018	SUZ-M71VA.TH	SUZ-M71VA.TH	Type C	CN806
2018	SUZ-M71VA-ET.TH	SUZ-M71VA-ET.TH	Type C	CN806
2018	SUZ-SA100VA2.TH	SUZ-SA100VA2.TH	Type C	CN806
2018	SUZ-SA71VA3.TH	SUZ-SA71VA3.TH	Type C	CN806
2018	SUZ-SM71VA.TH	SUZ-SM71VA.TH	Type C	CN806
2019	MUZ-AP20VG-E1	MUZ-AP20VG-E1	Type C	CN606
2019	MUZ-AP20VG-ER1	MUZ-AP20VG-ER1	Type C	CN606
2019	MUZ-AP20VG-ET1	MUZ-AP20VG-ET1	Type C	CN606
2019	MUZ-AP60VG-E1	MUZ-AP60VG-E1	Type C	CN606
2019	MUZ-AP60VG-ER1	MUZ-AP60VG-ER1	Type C	CN606
2019	MUZ-AP60VG-ET1	MUZ-AP60VG-ET1	Type C	CN606
2019	MUZ-AP71VG-E1	MUZ-AP71VG-E1	Type C	CN806
2019	MUZ-BT20VG-E1	MUZ-BT20VG-E1	Type C	CN606
2019	MUZ-BT20VG-ER1	MUZ-BT20VG-ER1	Type C	CN606
2019	MUZ-BT20VG-ET1	MUZ-BT20VG-ET1	Type C	CN606
2019	MUZ-BT25VG-E1	MUZ-BT25VG-E1	Type C	CN606
2019	MUZ-BT25VG-ER1	MUZ-BT25VG-ER1	Type C	CN606
2019	MUZ-BT25VG-ET1	MUZ-BT25VG-ET1	Type C	CN606
2019	MUZ-BT35VG-E1	MUZ-BT35VG-E1	Type C	CN606
2019	MUZ-BT35VG-ER1	MUZ-BT35VG-ER1	Type C	CN606
2019	MUZ-BT35VG-ET1	MUZ-BT35VG-ET1	Type C	CN606

fiscal_year	series	model	Relay cable	Connector
2019	MUZ-BT50VG-E1	MUZ-BT50VG-E1	Type C	CN606
2019	MUZ-BT50VG-ER1	MUZ-BT50VG-ER1	Type C	CN606
2019	MUZ-BT50VG-ET1	MUZ-BT50VG-ET1	Type C	CN606
2019	MUZ-EF25VG-E1	MUZ-EF25VG-E1	Type C	CN606
2019	MUZ-EF25VG-ER1	MUZ-EF25VG-ER1	Type C	CN606
2019	MUZ-EF25VG-ET1	MUZ-EF25VG-ET1	Type C	CN606
2019	MUZ-EF25VGH-E1	MUZ-EF25VGH-E1	Type C	CN606
2019	MUZ-EF35VG-E1	MUZ-EF35VG-E1	Type C	CN606
2019	MUZ-EF35VG-ER1	MUZ-EF35VG-ER1	Type C	CN606
2019	MUZ-EF35VG-ET1	MUZ-EF35VG-ET1	Type C	CN606
2019	MUZ-EF35VGH-E1	MUZ-EF35VGH-E1	Type C	CN606
2019	MUZ-EF42VG-E1	MUZ-EF42VG-E1	Type C	CN606
2019	MUZ-EF42VG-ER1	MUZ-EF42VG-ER1	Type C	CN606
2019	MUZ-EF42VG-ET1	MUZ-EF42VG-ET1	Type C	CN606
2019	MUZ-EF50VG-E1	MUZ-EF50VG-E1	Type C	CN606
2019	MUZ-EF50VG-ER1	MUZ-EF50VG-ER1	Type C	CN606
2019	MUZ-EF50VG-ET1	MUZ-EF50VG-ET1	Type C	CN606
2019	MUZ-HR25VF-E1	MUZ-HR25VF-E1	Type C	CN606
2019	MUZ-HR25VF-ER1	MUZ-HR25VF-ER1	Type C	CN606
2019	MUZ-HR35VF-E1	MUZ-HR35VF-E1	Type C	CN606
2019	MUZ-HR35VF-ER1	MUZ-HR35VF-ER1	Type C	CN606
2019	MUZ-HR42VF-E1	MUZ-HR42VF-E1	Type C	CN606
2019	MUZ-HR42VF-ER1	MUZ-HR42VF-ER1	Type C	CN606
2019	MUZ-HR50VF-E1	MUZ-HR50VF-E1	Type C	CN606
2019	MUZ-HR50VF-ER1	MUZ-HR50VF-ER1	Type C	CN606
2019	MUZ-LN25VG2-E1	MUZ-LN25VG2-E1	Type C	CN606
2019	MUZ-LN25VG2-ET1	MUZ-LN25VG2-ET1	Type C	CN606
2019	MUZ-LN25VGHZ2-E1	MUZ-LN25VGHZ2-E1	Type C	CN606
2019	MUZ-LN35VG2-E1	MUZ-LN35VG2-E1	Type C	CN606
2019	MUZ-LN35VG2-ET1	MUZ-LN35VG2-ET1	Type C	CN606
2019	MUZ-LN35VGHZ2-E1	MUZ-LN35VGHZ2-E1	Type C	CN606
2019	MUZ-LN50VG2-E1	MUZ-LN50VG2-E1	Type C	CN606
2019	MUZ-LN50VG2-ET1	MUZ-LN50VG2-ET1	Type C	CN606
2019	MXZ-2F42VF2-E1	MXZ-2F42VF2-E1	Type C	CN606
2019	MXZ-2F53VF2-E1	MXZ-2F53VF2-E1	Type C	CN606
2019	MXZ-2F53VFH2-E1	MXZ-2F53VFH2-E1	Type C	CN606
2019	MXZ-2F53VFH3-E1	MXZ-2F53VFH3-E1	Type C	CN606
2019	MXZ-2F53VFHZ-E1	MXZ-2F53VFHZ-E1	Type C	CN861
2019	MXZ-3F54VF2-E1	MXZ-3F54VF2-E1	Type C	CN861
2019	MXZ-3F54VF2-ET1	MXZ-3F54VF2-ET1	Type C	CN861
2019	MXZ-3F54VF3-E1	MXZ-3F54VF3-E1	Type C	CN861
2019	MXZ-3F54VF3-ET1	MXZ-3F54VF3-ET1	Type C	CN861
2019	MXZ-3F68VF2-E1	MXZ-3F68VF2-E1	Type C	CN861
2019	MXZ-3F68VF2-ET1	MXZ-3F68VF2-ET1	Type C	CN861
2019	MXZ-3F68VF3-E1	MXZ-3F68VF3-E1	Type C	CN861
2019	MXZ-3F68VF3-ET1	MXZ-3F68VF3-ET1	Type C	CN861
2019	MXZ-4F72VF2-E1	MXZ-4F72VF2-E1	Type C	CN861
2019	MXZ-4F72VF2-ET1	MXZ-4F72VF2-ET1	Type C	CN861
2019	MXZ-4F72VF3-E1	MXZ-4F72VF3-E1	Type C	CN861
2019	MXZ-4F72VF3-ET1	MXZ-4F72VF3-ET1	Type C	CN861
2019	MXZ-4F80VF2-E1	MXZ-4F80VF2-E1	Type C	CN861
2019	MXZ-4F80VF2-ET1	MXZ-4F80VF2-ET1	Type C	CN861
2019	MXZ-4F80VF3-E1	MXZ-4F80VF3-E1	Type C	CN861

fiscal_year	series	model	Relay cable	Connector
2019	MXZ-4F80VF3-ET1	MXZ-4F80VF3-ET1	Type C	CN861
2019	MXZ-4F83VF-E1	MXZ-4F83VF-E1	Type C	CN861
2019	MXZ-4F83VF-ET1	MXZ-4F83VF-ET1	Type C	CN861
2019	MXZ-4F83VFHZ-E1	MXZ-4F83VFHZ-E1	Type C	CN861
2019	MXZ-5F102VF-E1	MXZ-5F102VF-E1	Type C	CN861
2019	MXZ-5F102VF-ET1	MXZ-5F102VF-ET1	Type C	CN861
2019	SUZ-KA50VA6.TH-ER	SUZ-KA50VA6.TH-ER	Type C	CN606
2019	SUZ-KA60VA6.TH-ER	SUZ-KA60VA6.TH-ER	Type C	CN806
2019	SUZ-M25VA-ETR2.TH	SUZ-M25VA-ETR2.TH	Type C	CN606
2019	SUZ-M25VAR1.TH	SUZ-M25VAR1.TH	Type C	CN606
2019	SUZ-M25VAR2.TH	SUZ-M25VAR2.TH	Type C	CN606
2019	SUZ-M35VA-ETR2.TH	SUZ-M35VA-ETR2.TH	Type C	CN606
2019	SUZ-M35VAR1.TH	SUZ-M35VAR1.TH	Type C	CN606
2019	SUZ-M35VAR2.TH	SUZ-M35VAR2.TH	Type C	CN606
2019	SUZ-M50VA-ETR2.TH	SUZ-M50VA-ETR2.TH	Type C	CN606
2019	SUZ-M50VAR1.TH	SUZ-M50VAR1.TH	Type C	CN606
2019	SUZ-M50VAR2.TH	SUZ-M50VAR2.TH	Type C	CN606
2019	SUZ-M60VA-ETR2.TH	SUZ-M60VA-ETR2.TH	Type C	CN806
2019	SUZ-M60VAR1.TH	SUZ-M60VAR1.TH	Type C	CN806
2019	SUZ-M60VAR2.TH	SUZ-M60VAR2.TH	Type C	CN806
2019	SUZ-M71VA-ETR1.TH	SUZ-M71VA-ETR1.TH	Type C	CN806
2019	SUZ-M71VAR1.TH	SUZ-M71VAR1.TH	Type C	CN806
2020	MUZ-AP25VG-E3	MUZ-AP25VG-E3	Type C	CN606
2020	MUZ-AP25VG-ET3	MUZ-AP25VG-ET3	Type C	CN606
2020	MUZ-AP25VGH-E3	MUZ-AP25VGH-E3	Type C	CN606
2020	MUZ-AP35VG-E3	MUZ-AP35VG-E3	Type C	CN606
2020	MUZ-AP35VG-ET3	MUZ-AP35VG-ET3	Type C	CN606
2020	MUZ-AP35VGH-E3	MUZ-AP35VGH-E3	Type C	CN606
2020	MUZ-FT25VGHZ-E1	MUZ-FT25VGHZ-E1	Type C	CN606
2020	MUZ-FT25VGHZ-ET1	MUZ-FT25VGHZ-ET1	Type C	CN606
2020	MUZ-FT25VGHZ-SC1	MUZ-FT25VGHZ-SC1	Type C	CN606
2020	MUZ-FT35VGHZ-E1	MUZ-FT35VGHZ-E1	Type C	CN606
2020	MUZ-FT35VGHZ-ET1	MUZ-FT35VGHZ-ET1	Type C	CN606
2020	MUZ-FT35VGHZ-SC1	MUZ-FT35VGHZ-SC1	Type C	CN606
2020	MUZ-FT50VGHZ-E1	MUZ-FT50VGHZ-E1	Type C	CN606
2020	MUZ-FT50VGHZ-ET1	MUZ-FT50VGHZ-ET1	Type C	CN606
2020	MUZ-FT50VGHZ-SC1	MUZ-FT50VGHZ-SC1	Type C	CN606
2020	MUZ-HR25VF-E2	MUZ-HR25VF-E2	Type C	CN606
2020	MUZ-HR25VF-ET2	MUZ-HR25VF-ET2	Type C	CN606
2020	MUZ-HR35VF-E2	MUZ-HR35VF-E2	Type C	CN606
2020	MUZ-HR35VF-ET2	MUZ-HR35VF-ET2	Type C	CN606
2020	MUZ-HR42VF-E2	MUZ-HR42VF-E2	Type C	CN606
2020	MUZ-HR42VF-ET2	MUZ-HR42VF-ET2	Type C	CN606
2020	MUZ-HR50VF-E2	MUZ-HR50VF-E2	Type C	CN606
2020	MUZ-HR50VF-ET2	MUZ-HR50VF-ET2	Type C	CN606
2020	MUZ-HR60VF-E1	MUZ-HR60VF-E1	Type C	CN606
2020	MUZ-HR60VF-ER1	MUZ-HR60VF-ER1	Type C	CN606
2020	MUZ-HR60VF-ET1	MUZ-HR60VF-ET1	Type C	CN606
2020	MUZ-HR71VF-E1	MUZ-HR71VF-E1	Type C	CN606
2020	MUZ-HR71VF-ER1	MUZ-HR71VF-ER1	Type C	CN606
2020	MUZ-HR71VF-ET1	MUZ-HR71VF-ET1	Type C	CN606
2020	MXZ-6F122VF-E1	MXZ-6F122VF-E1	Type C	CN861
2020	MXZ-6F122VF-ET1	MXZ-6F122VF-ET1	Type C	CN861

fiscal_year	series	model	Relay cable	Connector
2020	SUZ-KA71VA6.TH-ER	SUZ-KA71VA6.TH-ER	Type C	CN806

<For Australia>

fiscal_year	series	model	Relay cable	Connector
2005	FB50VA	MUZ-FB50VA(H)-A1	Type AD	CN605
2005	FB50VA	MUFZ-FB50VA(H)-A1	Type AD	CN605
2005	GB50/FB35/GE	MUZ-GB50VA-A2/FB35VAH/GE25/35/50	Type B	CN606
2005	MUZ-FA GA KA small RAC(1)	MUZ-GA25/35VA(H) GB25/35VA(H) SUZ25	Type AD	CN606
2005	MUZ-FA GA KA small RAC(2)	MUZ-GA25/35VA(H) SUZ25	Type AD	CN606
2005	MUZ-FA GA KA small RAC(3)	MUZ-GA25/35VA(H) FA25/35VA-A1 SUZ25	Type AD	CN606
2005	MUZ-FB25/35	MUZ-FB25VA(H)/35VA-A1 GC25/35VA	Type B	CN606
2005	MUZ-FB35VAH	MUZ-FB35VAH-A1	Type B	CN606
2005	MUZ-GA GB big RAC-A(1)	MUZ-GA50VA-A1/GA60VA-A1,A2 /GA71VA-A1/GA80VA-A1/GB50VA-A1	Type AD	CN605
2005	MUZ-GA GB big RAC-A(2)	MUZ-GA50VA-A1/GA60VA-A1,A2 /GA71VA-A1/GA80VA-A1/GB50VA-A1	Type AD	CN605
2005	MUZ-GA GB big RAC-A(3)	MUZ-GA50VA-A1/GA60VA-A1,A2 /GA71VA-A1/GA80VA-A1/GB50VA-A1	Type AD	CN605
2005	MUZ-GA60VA big RAC-B	MUZ-GA60VA-A3	Type AD	CN605
2005	SUZ-KA25VA.TH-A	SUZ-KA25VA.TH-A	Type AD	CN606
2005	SUZ-KA35VA.TH-A	SUZ-KA35VA.TH-A	Type AD	CN606
2005	SUZ-KA50VA.TH-A	SUZ-KA50VA.TH-A	Type AD	CN605
2005	SUZ-KA60VA.TH-A	SUZ-KA60VA.TH-A	Type AD	CN605
2005	SUZ-KA71VA.TH-A	SUZ-KA71VA.TH-A	Type AD	CN605
2007	SUZ-KA50VA#1.TH-A	SUZ-KA50VA#1.TH-A	Type AD	CN605
2007	SUZ-KA60VA#1.TH-A	SUZ-KA60VA#1.TH-A	Type AD	CN605
2007	SUZ-KA71VA#1.TH-A	SUZ-KA71VA#1.TH-A	Type AD	CN605
2008	MUZ-FB25VA-A1	MUZ-FB25VA-A1	Type B	CN606
2008	MUZ-FB35VA-A1	MUZ-FB35VA-A1	Type B	CN606
2008	MUZ-FB35VAH-A1	MUZ-FB35VAH-A1	Type B	CN606
2008	MUZ-FB50VA-A1	MUZ-FB50VA-A1	Type AD	CN605
2008	MUZ-FB50VAH-A1	MUZ-FB50VAH-A1	Type AD	CN605
2008	SUZ-KA25VAR1.TH-A	SUZ-KA25VAR1.TH-A	Type B	CN606
2008	SUZ-KA35VAR1.TH-A	SUZ-KA35VAR1.TH-A	Type B	CN606
2008	SUZ-KA50VAR2.TH-A	SUZ-KA50VAR2.TH-A	Type B	CN606
2008	SUZ-KA60VAR2.TH-A	SUZ-KA60VAR2.TH-A	Type AD	CN605
2009	MUFZ-FB50VAH-A1	MUFZ-FB50VAH-A1	Type AD	CN606
2009	MUY-GC25VA-A1	MUY-GC25VA-A1	Type B	CN606
2009	MUY-GC35VA-A1	MUY-GC35VA-A1	Type B	CN606
2009	MUY-GC71	MUY-GC71VA-A1	Type AD	CN605
2009	MUZ 09model	MUZ-GE60/71/80VA-A1	Type C	CN806
2009	MUZ-GE25VA-A1	MUZ-GE25VA-A1	Type B	CN606
2009	MUZ-GE35VA-A1	MUZ-GE35VA-A1	Type B	CN606
2009	MUZ-GE50VA-A1	MUZ-GE50VA-A1	Type B	CN606
2010	MUZ-GE60VA-A1	MUZ-GE60VA-A1	Type C	CN806
2010	MUZ-GE71VA-A1	MUZ-GE71VA-A1	Type C	CN806
2010	MUZ-GE80VA-A1	MUZ-GE80VA-A1	Type C	CN806
2010	SUZ-KA25VA2.TH-A	SUZ-KA25VA2.TH-A	Type B	CN606
2010	SUZ-KA35VA2.TH-A	SUZ-KA35VA2.TH-A	Type B	CN606
2010	SUZ-KA50VA2.TH-A	SUZ-KA50VA2.TH-A	Type B	CN606
2010	SUZ-KA60VA2.TH-A	SUZ-KA60VA2.TH-A	Type AD	CN605
2010	SUZ-KA71VA2.TH-A	SUZ-KA71VA2.TH-A	Type C	CN806
2011	MUZ-GE33VA-A1	MUZ-GE33VA-A1	Type B	CN606
2011	MUZ-GE42VA-A1	MUZ-GE42VA-A1	Type B	CN606
2011	SUZ-KA25VA3.TH-A	SUZ-KA25VA3.TH-A	Type B	CN606
2011	SUZ-KA50VA3.TH-A	SUZ-KA50VA3.TH-A	Type B	CN606
2011	SUZ-KA60VA3.TH-A	SUZ-KA60VA3.TH-A	Type C	CN806

fiscal_year	series	model	Relay cable	Connector
2011	SUZ-KA71VA3.TH-A	SUZ-KA71VA3.TH-A	Type C	CN806
2012	MUZ-GE25VA-A2	MUZ-GE25VA-A2	Type B	CN606
2012	MUZ-GE35VA2-A1	MUZ-GE35VA2-A1	Type B	CN606
2012	MUZ-GE35VA2-A2	MUZ-GE35VA2-A2	Type B	CN606
2012	MUZ-GE50VA2-A1	MUZ-GE50VA2-A1	Type C	CN806
2012	MUZ-GE80VA2-A1	MUZ-GE80VA2-A1	Type C	CN806
2013	MUZ-EF25VE-A1	MUZ-EF25VE-A1	Type C	CN606
2013	MUZ-EF35VE-A1	MUZ-EF35VE-A1	Type C	CN606
2013	MUZ-EF42VE-A1	MUZ-EF42VE-A1	Type C	CN606
2013	MUZ-EF50VE-A1	MUZ-EF50VE-A1	Type C	CN606
2013	MUZ-GE60VAD-A1	MUZ-GE60VAD-A1	Type C	CN806
2013	MUZ-GE71VAD-A1	MUZ-GE71VAD-A1	Type C	CN806
2013	MUZ-GE80VAD-A1	MUZ-GE80VAD-A1	Type C	CN806
2014	MUFZ-KJ25VE-A1	MUFZ-KJ25VE-A1	Type C	CN606
2014	MUFZ-KJ35VE-A1	MUFZ-KJ35VE-A1	Type C	CN606
2014	MUFZ-KJ50VE-A1	MUFZ-KJ50VE-A1	Type C	CN806
2014	MUFZ-KJ50VEHZ-A1	MUFZ-KJ50VEHZ-A1	Type C	CN806
2014	MUZ-GE25VAD-A1	MUZ-GE25VAD-A1	Type B	CN606
2014	MUZ-GE35VAD-A1	MUZ-GE35VAD-A1	Type B	CN606
2014	MUZ-GE42VAD-A1	MUZ-GE42VAD-A1	Type B	CN606
2014	MUZ-GE50VAD-A1	MUZ-GE50VAD-A1	Type B	CN606
2015	MUZ-FH25VE-A1	MUZ-FH25VE-A1	Type C	CN606
2015	MUZ-FH25VEHZ-A1	MUZ-FH25VEHZ-A1	Type C	CN606
2015	MUZ-FH35VE-A1	MUZ-FH35VE-A1	Type C	CN606
2015	MUZ-FH35VEHZ-A1	MUZ-FH35VEHZ-A1	Type C	CN606
2015	MUZ-FH50VE-A1	MUZ-FH50VE-A1	Type C	CN806
2015	MUZ-FH50VEHZ-A1	MUZ-FH50VEHZ-A1	Type C	CN806
2015	MUZ-GL25VGD-A1	MUZ-GL25VGD-A1	Type C	CN606
2015	MUZ-GL35VGD-A1	MUZ-GL35VGD-A1	Type C	CN606
2015	MUZ-GL42VGD-A1	MUZ-GL42VGD-A1	Type C	CN606
2015	MUZ-GL50VGD-A1	MUZ-GL50VGD-A1	Type C	CN806
2015	MUZ-GL60VGD-A1	MUZ-GL60VGD-A1	Type C	CN806
2015	MUZ-GL71VGD-A1	MUZ-GL71VGD-A1	Type C	CN806
2015	MUZ-GL80VGD-A1	MUZ-GL80VGD-A1	Type C	CN806
2015	MXZ-2B52VA-A1	MXZ-2B52VA-A1	Type AD	CN606
2015	MXZ-2C52VA-A1	MXZ-2C52VA-A1	Type AD	CN606
2015	MXZ-2D52VA-A1	MXZ-2D52VA-A1	Type AD	CN606
2015	MXZ-2D52VA-A2	MXZ-2D52VA-A2	Type AD	CN606
2015	MXZ-3B54VA-A1	MXZ-3B54VA-A1	Type AD	CN605
2015	MXZ-3C54VA-A1	MXZ-3C54VA-A1	Type AD	CN605
2015	MXZ-3D54VA-A1	MXZ-3D54VA-A1	Type C	CN861
2015	MXZ-3D54VA-A2	MXZ-3D54VA-A2	Type C	CN861
2015	MXZ-4B71VA-A1	MXZ-4B71VA-A1	Type AD	CN605
2015	MXZ-4B80VA-A1	MXZ-4B80VA-A1	Type AD	CN605
2015	MXZ-4C71VA-A1	MXZ-4C71VA-A1	Type AD	CN605
2015	MXZ-4C80VA-A1 (a)	MXZ-4C80VA-A1 (a)	Type AD	CN605
2015	MXZ-4C80VA-A1 (b)	MXZ-4C80VA-A1 (b)	Type C	CN605
2015	MXZ-4D71VA-A1	MXZ-4D71VA-A1	Type C	CN861
2015	MXZ-4D71VA-A2	MXZ-4D71VA-A2	Type C	CN861
2015	MXZ-4D80VA-A1	MXZ-4D80VA-A1	Type C	CN605
2015	MXZ-5B100VA-A1	MXZ-5B100VA-A1	Type AD	CN605
2015	MXZ-5C100VA-A1 (a)	MXZ-5C100VA-A1 (a)	Type AD	CN605
2015	MXZ-5C100VA-A1 (b)	MXZ-5C100VA-A1 (b)	Type C	CN605

fiscal_year	series	model	Relay cable	Connector
2015	MXZ-5D100VA-A1	MXZ-5D100VA-A1	Type C	CN605
2015	MXZ-6C120VA-A1	MXZ-6C120VA-A1	Type C	CN861
2015	MXZ-6C120VA-A2	MXZ-6C120VA-A2	Type C	CN861
2015	MXZ-6D120VA-A1	MXZ-6D120VA-A1	Type C	CN861
2016	MUZ-GE25VAD2-A1	MUZ-GE25VAD2-A1	Type B	CN606
2016	MUZ-GE35VAD2-A1	MUZ-GE35VAD2-A1	Type B	CN606
2016	MUZ-GE42VAD2-A1	MUZ-GE42VAD2-A1	Type B	CN606
2016	MUZ-GE50VAD2-A1	MUZ-GE50VAD2-A1	Type B	CN606
2016	MXZ-2E52VAD-A1	MXZ-2E52VAD-A1	Type C	CN861
2016	MXZ-3E54VAD-A1	MXZ-3E54VAD-A1	Type C	CN861
2016	MXZ-4E71VAD-A1	MXZ-4E71VAD-A1	Type C	CN861
2016	MXZ-4E80VAD-A1	MXZ-4E80VAD-A1	Type C	CN861
2016	MXZ-5E100VAD-A1	MXZ-5E100VAD-A1	Type C	CN861
2016	MXZ-6E120VAD-A1	MXZ-6E120VAD-A1	Type C	CN861
2017	MUY-GN25VF-A1	MUY-GN25VF-A1	Type C	CN606
2017	MUY-GN35VF-A1	MUY-GN35VF-A1	Type C	CN606
2017	MUY-GN42VF-A1	MUY-GN42VF-A1	Type C	CN606
2017	MUY-GN50VF-A1	MUY-GN50VF-A1	Type C	CN606
2017	MUY-GN60VF-A1	MUY-GN60VF-A1	Type C	CN606
2017	MUY-GN71VF-A1	MUY-GN71VF-A1	Type C	CN806
2017	MUY-GN80VF-A1	MUY-GN80VF-A1	Type C	CN806
2018	MUZ-AP25VG-A1	MUZ-AP25VG-A1	Type C	CN606
2018	MUZ-AP25VGD-A1	MUZ-AP25VGD-A1	Type C	CN606
2018	MUZ-AP35VG-A1	MUZ-AP35VG-A1	Type C	CN606
2018	MUZ-AP35VGD-A1	MUZ-AP35VGD-A1	Type C	CN606
2018	MUZ-AP42VG-A1	MUZ-AP42VG-A1	Type C	CN606
2018	MUZ-AP42VGD-A1	MUZ-AP42VGD-A1	Type C	CN606
2018	MUZ-AP50VG-A1	MUZ-AP50VG-A1	Type C	CN606
2018	MUZ-AP50VGD-A1	MUZ-AP50VGD-A1	Type C	CN606
2018	MUZ-AP60VG-A1	MUZ-AP60VG-A1	Type C	CN606
2018	MUZ-AP60VGD-A1	MUZ-AP60VGD-A1	Type C	CN606
2018	MUZ-AP71VG-A1	MUZ-AP71VG-A1	Type C	CN806
2018	MUZ-AP71VGD-A1	MUZ-AP71VGD-A1	Type C	CN806
2018	MUZ-AP80VG-A1	MUZ-AP80VG-A1	Type C	CN806
2018	MUZ-AP80VGD-A1	MUZ-AP80VGD-A1	Type C	CN806
2018	MUZ-LN25VG-A1	MUZ-LN25VG-A1	Type C	CN606
2018	MUZ-LN25VGHZ-A1	MUZ-LN25VGHZ-A1	Type C	CN606
2018	MUZ-LN35VG-A1	MUZ-LN35VG-A1	Type C	CN606
2018	MUZ-LN35VGHZ-A1	MUZ-LN35VGHZ-A1	Type C	CN606
2018	MUZ-LN50VG-A1	MUZ-LN50VG-A1	Type C	CN606
2018	MUZ-LN50VGHZ-A1	MUZ-LN50VGHZ-A1	Type C	CN806
2018	MUZ-LN60VG-A1	MUZ-LN60VG-A1	Type C	CN806
2018	MXZ-2D52VA2-A1	MXZ-2D52VA2-A1	Type AD	CN606
2018	SUZ-KA25VAD2.TH-A	SUZ-KA25VAD2.TH-A	Type C	CN606
2018	SUZ-KA35VAD2.TH-A	SUZ-KA35VAD2.TH-A	Type C	CN606
2018	SUZ-KA50VAD2.TH-A	SUZ-KA50VAD2.TH-A	Type C	CN806
2018	SUZ-KA60VAD2.TH-A	SUZ-KA60VAD2.TH-A	Type C	CN806
2018	SUZ-KA71VAD2.TH-A	SUZ-KA71VAD2.TH-A	Type C	CN806
2019	MXZ-2E52VAD2-A1	MXZ-2E52VAD2-A1	Type C	CN861
2019	MXZ-3E54VAD2-A1	MXZ-3E54VAD2-A1	Type C	CN861
2019	MXZ-4E71VAD2-A1	MXZ-4E71VAD2-A1	Type C	CN861
2019	MXZ-4E80VAD2-A1	MXZ-4E80VAD2-A1	Type C	CN861
2019	MXZ-5E100VAD2-A1	MXZ-5E100VAD2-A1	Type C	CN861

fiscal_year	series	model	Relay cable	Connector
2019	MXZ-6E120VAD2-A1	MXZ-6E120VAD2-A1	Type C	CN861
2020	MUFZ-KW25VG-A1	MUFZ-KW25VG-A1	Type C	CN606
2020	MUFZ-KW35VG-A1	MUFZ-KW35VG-A1	Type C	CN606
2020	MUFZ-KW42VG-A1	MUFZ-KW42VG-A1	Type C	CN606
2020	MUFZ-KW50VG-A1	MUFZ-KW50VG-A1	Type C	CN806
2020	MUFZ-KW50VGHZ-A1	MUFZ-KW50VGHZ-A1	Type C	CN806
2020	MUFZ-KW60VG-A1	MUFZ-KW60VG-A1	Type C	CN806
2020	MUFZ-KW60VGHZ-A1	MUFZ-KW60VGHZ-A1	Type C	CN806
2020	MUZ-AP20VG-A1	MUZ-AP20VG-A1	Type C	CN606
2020	MUZ-EF25VG-A1	MUZ-EF25VG-A1	Type C	CN606
2020	MUZ-EF35VG-A1	MUZ-EF35VG-A1	Type C	CN606
2020	MUZ-EF42VG-A1	MUZ-EF42VG-A1	Type C	CN606
2020	MUZ-EF50VG-A1	MUZ-EF50VG-A1	Type C	CN606
2020	MUZ-LN25VG2-A1	MUZ-LN25VG2-A1	Type C	CN606
2020	MUZ-LN25VGHZ2-A1	MUZ-LN25VGHZ2-A1	Type C	CN606
2020	MUZ-LN35VG2-A1	MUZ-LN35VG2-A1	Type C	CN606
2020	MUZ-LN35VGHZ2-A1	MUZ-LN35VGHZ2-A1	Type C	CN606
2020	MUZ-LN50VG2-A1	MUZ-LN50VG2-A1	Type C	CN606
2020	MXZ-2F52VF-A1	MXZ-2F52VF-A1	Type C	CN606
2020	MXZ-2F52VGD-A1	MXZ-2F52VGD-A1	Type C	CN861
2020	MXZ-3F54VGD-A1	MXZ-3F54VGD-A1	Type C	CN861
2020	MXZ-4F71VGD-A1	MXZ-4F71VGD-A1	Type C	CN861
2020	MXZ-4F80VGD-A1	MXZ-4F80VGD-A1	Type C	CN861
2020	MXZ-5F100VGD-A1	MXZ-5F100VGD-A1	Type C	CN861
2020	MXZ-6F120VGD-A1	MXZ-6F120VGD-A1	Type C	CN861
2020	SUZ-M25VAD-A.TH	SUZ-M25VAD-A.TH	Type C	CN606
2020	SUZ-M35VAD-A.TH	SUZ-M35VAD-A.TH	Type C	CN606
2020	SUZ-M50VAD-A.TH	SUZ-M50VAD-A.TH	Type C	CN606
2020	SUZ-M60VAD-A.TH	SUZ-M60VAD-A.TH	Type C	CN806
2020	SUZ-M71VAD-A.TH	SUZ-M71VAD-A.TH	Type C	CN806

<For Asia>

fiscal_year	series	model	Relay cable	Connector
2010	MUY-GE10VA-R1	MUY-GE10VA-R1	Type B	CN606
2010	MUY-GE13VA-R1	MUY-GE13VA-R1	Type B	CN606
2010	MUY-GE15VA-R1	MUY-GE15VA-R1	Type B	CN606
2010	MUY-GE18VA-R1	MUY-GE18VA-R1	Type B	CN606
2010	MUY-GE24VA-R1	MUY-GE24VA-R1	Type C	CN806
2010	MXY-2E20VA-R1	MXY-2E20VA-R1	Type AD	CN606
2010	MXY-3A28VA-R6	MXY-3A28VA-R6	Type AD	CN605
2010	MXY-4A28VA-R6	MXY-4A28VA-R6	Type AD	CN605
2010	MXY-4A38VA-P2	MXY-4A38VA-P2	Type AD	CN605
2010	MXY-4A38VA-P3	MXY-4A38VA-P3	Type AD	CN605
2011	MXY-2E20VA-R2	MXY-2E20VA-R2	Type AD	CN606
2011	MXY-3A28VA-R7	MXY-3A28VA-R7	Type AD	CN605
2011	MXY-4A28VA-R7	MXY-4A28VA-R7	Type AD	CN605
2011	MUZ-SFG09VA-T1	MUZ-SFG09VA-T1	Type B	CN606
2011	MUZ-SFG13VA-T1	MUZ-SFG13VA-T1	Type B	CN606
2012	MUY-GE10VA-R2	MUY-GE10VA-R2	Type B	CN606
2012	MUY-GE13VA-R2	MUY-GE13VA-R2	Type B	CN606
2012	MUY-GE15VA-R2	MUY-GE15VA-R2	Type B	CN606
2012	MUY-GE24VA-R2	MUY-GE24VA-R2	Type C	CN806
2012	MXY-2H20VA-T1	MXY-2H20VA-T1	Type AD	CN606
2012	MXY-3H28VA-T1	MXY-3H28VA-T1	Type AD	CN605
2012	MXY-4A38VA-P3	MXY-4A38VA-P3	Type AD	CN605
2012	MUZ-EF09VA-T1	MUZ-EF09VA-T1	Type C	CN606
2012	MUZ-EF13VA-T1	MUZ-EF13VA-T1	Type C	CN606
2012	MUZ-SGH09VA-T1	MUZ-SGH09VA-T1	Type B	CN606
2012	MUZ-SGH13VA-T1	MUZ-SGH13VA-T1	Type B	CN606
2012	MUZ-SGH15VA-T1	MUZ-SGH15VA-T1	Type B	CN606
2012	MUZ-SGH18VA-T1	MUZ-SGH18VA-T1	Type C	CN606
2012	MUZ-SGH24VA-T1	MUZ-SGH24VA-T1	Type C	CN806
2013	SUY-KA18VA.TH	SUY-KA18VA.TH	Type C	CN606
2013	SUY-KA24VA.TH	SUY-KA24VA.TH	Type C	CN806
2013	MUZ-FK09VA-T1	MUZ-FK09VA-T1	Type C	CN606
2013	MUZ-FK13VA-T1	MUZ-FK13VA-T1	Type C	CN606
2014	MUY-GK09VA-T1	MUY-GK09VA-T1	Type B	CN606
2014	MUY-GK13VA-T1	MUY-GK13VA-T1	Type B	CN606
2014	MUY-GK15VA-T1	MUY-GK15VA-T1	Type B	CN606
2014	MUY-GK18VA-T1	MUY-GK18VA-T1	Type B	CN606
2014	MUY-GK24VA-T1	MUY-GK24VA-T1	Type C	CN806
2014	MUY-GM18VF-T1	MUY-GM18VF-T1	Type C	CN606
2014	SUY-KA18VA.TH-T	SUY-KA18VA.TH-T	Type C	CN606
2014	SUY-KA24VA.TH-T	SUY-KA24VA.TH-T	Type C	CN806
2014	SUY-KA30VA.TH-T	SUY-KA30VA.TH-T	Type C	CN806
2014	SUY-KA36VA.TH-T	SUY-KA36VA.TH-T	Type C	CN806
2015	MUY-FL10VE-R1	MUY-FL10VE-R1	Type C	CN606
2015	MUY-GL10VA-R1	MUY-GL10VA-R1	Type B	CN606
2015	MUY-GL18VA-R1	MUY-GL18VA-R1	Type C	CN806
2015	MXY-2G20VA-R1	MXY-2G20VA-R1	Type AD	CN606
2015	MXY-3G28VA-R1	MXY-3G28VA-R1	Type C	CN861
2015	MXY-4G28VA-R1	MXY-4G28VA-R1	Type C	CN861
2015	MXY-4G38VA-R1	MXY-4G38VA-R1	Type C	CN861
2015	MXY-5G48VA-R1	MXY-5G48VA-R1	Type C	CN861
2015	MUZ-FK18VA-T1	MUZ-FK18VA-T1	Type C	CN806

fiscal_year	series	model	Relay cable	Connector
2016	MXY-3G28VA-R2	MXY-3G28VA-R2	Type C	CN861
2016	MXY-4G28VA-R2	MXY-4G28VA-R2	Type C	CN861
2016	MUY-GM09VF-T1	MUY-GM09VF-T1	Type C	CN606
2016	MUY-GM13VF-T1	MUY-GM13VF-T1	Type C	CN606
2016	MUY-GM15VF-T1	MUY-GM15VF-T1	Type C	CN606
2016	MUY-GM24VF-T1	MUY-GM24VF-T1	Type C	CN806
2016	MUY-GM30VF-T1	MUY-GM30VF-T1	Type C	CN806
2016	MUY-GN09VF-T1	MUY-GN09VF-T1	Type C	CN606
2016	MUY-GN13VF-T1	MUY-GN13VF-T1	Type C	CN606
2016	MUY-GN15VF-T1	MUY-GN15VF-T1	Type C	CN606
2016	MUY-GN18VF-T1	MUY-GN18VF-T1	Type C	CN606
2016	MUY-GN24VF-T1	MUY-GN24VF-T1	Type C	CN806
2016	MUY-GN30VF-T1	MUY-GN30VF-T1	Type C	CN806
2016	MUZ-FM09VF-T1	MUZ-FM09VF-T1	Type C	CN606
2016	MUZ-FM13VF-T1	MUZ-FM13VF-T1	Type C	CN606
2016	MUZ-FM18VF-T1	MUZ-FM18VF-T1	Type C	CN806
2016	MUZ-LN09VF-T1	MUZ-LN09VF-T1	Type C	CN606
2016	MUZ-LN13VF-T1	MUZ-LN13VF-T1	Type C	CN606
2016	MUZ-LN18VF-T1	MUZ-LN18VF-T1	Type C	CN606
2016	SUY-SA18VA.TH-T	SUY-SA18VA.TH-T	Type C	CN606
2016	SUY-SA24VA.TH-T	SUY-SA24VA.TH-T	Type C	CN606
2016	SUY-SA30VA.TH-T	SUY-SA30VA.TH-T	Type C	CN806
2016	SUY-SA36VA.TH-T	SUY-SA36VA.TH-T	Type C	CN806
2016	MUY-GE22NA-C1	MUY-GE22NA-C1	Type C	CN606
2016	MUY-GE25NA-C1	MUY-GE25NA-C1	Type C	CN606
2016	MUY-GE35NA-C1	MUY-GE35NA-C1	Type C	CN606
2016	MUY-GE42NA-C1	MUY-GE42NA-C1	Type C	CN606
2016	MUY-GE50NA-C1	MUY-GE50NA-C1	Type C	CN806
2016	MUY-GE60NA-C1	MUY-GE60NA-C1	Type C	CN806
2016	MUY-GE71NA-C1	MUY-GE71NA-C1	Type C	CN806
2016	MUY-GN10VF-D1	MUY-GN10VF-D1	Type C	CN606
2016	MUY-GN13VF-D1	MUY-GN13VF-D1	Type C	CN606
2016	MUY-GN15VF-D1	MUY-GN15VF-D1	Type C	CN606
2016	MUY-GN18VF-D1	MUY-GN18VF-D1	Type C	CN606
2016	MUY-GN22VF-D1	MUY-GN22VF-D1	Type C	CN606
2016	MUY-GN26VF-D1	MUY-GN26VF-D1	Type C	CN806
2016	MUZ-GE22NA-C1	MUZ-GE22NA-C1	Type C	CN606
2016	MUZ-GE25NA-C1	MUZ-GE25NA-C1	Type C	CN606
2016	MUZ-GE35NA-C1	MUZ-GE35NA-C1	Type C	CN606
2016	MUZ-GE42NA-C1	MUZ-GE42NA-C1	Type C	CN606
2016	MUZ-GE50NA-C1	MUZ-GE50NA-C1	Type C	CN806
2016	MUZ-GE60NA-C1	MUZ-GE60NA-C1	Type C	CN806
2016	MUZ-GE71NA-C1	MUZ-GE71NA-C1	Type C	CN806
2016	MUZ-HJ35VA-PK1	MUZ-HJ35VA-PK1	Type C	CN606
2016	MUZ-HJ50VA-PK1	MUZ-HJ50VA-PK1	Type C	CN606
2016	MUZ-HJ71VA-PK1	MUZ-HJ71VA-PK1	Type C	CN606
2016	MUZ-HL25VA-V1	MUZ-HL25VA-V1	Type C	CN606
2016	MUZ-HL35VA-V1	MUZ-HL35VA-V1	Type C	CN606
2016	MUZ-HL50VA-V1	MUZ-HL50VA-V1	Type C	CN606
2017	MXY-2G20VA2-R1	MXY-2G20VA2-R1	Type C	CN606
2017	MXY-2G20VA-R2	MXY-2G20VA-R2	Type AD	CN606
2017	MXY-3G28VA2-R1	MXY-3G28VA2-R1	Type C	CN861
2017	MXY-4G33VA2-R1	MXY-4G33VA2-R1	Type C	CN861

fiscal_year	series	model	Relay cable	Connector
2017	MXY-4G38VA2-R1	MXY-4G38VA2-R1	Type C	CN861
2017	MXY-5G48VA2-R1	MXY-5G48VA2-R1	Type C	CN861
2017	SUY-KA30VA.TH	SUY-KA30VA.TH	Type C	CN806
2017	SUY-KA36VA.TH	SUY-KA36VA.TH	Type C	CN806
2017	MUY-JP09VF-TH1	MUY-JP09VF-TH1	Type C	CN606
2017	MUY-JP13VF-TH1	MUY-JP13VF-TH1	Type C	CN606
2017	MUY-JP15VF-TH1	MUY-JP15VF-TH1	Type C	CN606
2017	MUY-JP18VF-TH1	MUY-JP18VF-TH1	Type C	CN606
2017	MUY-JP24VF-TH1	MUY-JP24VF-TH1	Type C	CN606
2017	MUY-GF24VA-HK1	MUY-GF24VA-HK1	Type C	CN806
2017	MUY-GJ10VA-HK1	MUY-GJ10VA-HK1	Type C	CN606
2017	MUY-GJ13VA-HK1	MUY-GJ13VA-HK1	Type C	CN606
2017	MUY-GK18VA-HK1	MUY-GK18VA-HK1	Type C	CN606
2017	MXZ-2C50NA-C1	MXZ-2C50NA-C1	Type A	CN606
2017	MXZ-4C80NA-C1	MXZ-4C80NA-C1	Type C	CN605
2017	MXZ-5C100NA-CZ	MXZ-5C100NA-CZ	Type C	CN605
2018	MUY-GR09VF-TH1	MUY-GR09VF-TH1	Type C	CN606
2018	MUY-GR13VF-TH1	MUY-GR13VF-TH1	Type C	CN606
2018	MUY-GR15VF-TH1	MUY-GR15VF-TH1	Type C	CN606
2018	MUY-GR18VF-TH1	MUY-GR18VF-TH1	Type C	CN606
2018	MUY-GR24VF-TH1	MUY-GR24VF-TH1	Type C	CN606
2018	MUY-GR30VF-TH1	MUY-GR30VF-TH1	Type C	CN806
2018	SUY-SA18VA2.TH-TH	SUY-SA18VA2.TH-TH	Type C	CN606
2018	SUY-SA24VA2.TH-TH	SUY-SA24VA2.TH-TH	Type C	CN606
2018	SUY-SA30VA2.TH-TH	SUY-SA30VA2.TH-TH	Type C	CN806
2018	MUY-GN10VA-SG1	MUY-GN10VA-SG1	Type C	CN606
2018	MUY-GN13VA-SG1	MUY-GN13VA-SG1	Type C	CN606
2018	MUY-GN15VA-SG1	MUY-GN15VA-SG1	Type C	CN606
2018	MUY-GN18VA-SG1	MUY-GN18VA-SG1	Type C	CN606
2018	MUY-GN24VA-SG1	MUY-GN24VA-SG1	Type C	CN806
2018	MUY-JP10VF-DA1	MUY-JP10VF-DA1	Type C	CN606
2018	MUY-JP10VF-NE1	MUY-JP10VF-NE1	Type C	CN606
2018	MUY-JP13VF-DA1	MUY-JP13VF-DA1	Type C	CN606
2018	MUY-JP13VF-NE1	MUY-JP13VF-NE1	Type C	CN606
2018	MUY-JP15VF-DA1	MUY-JP15VF-DA1	Type C	CN606
2018	MUY-JP18VF-DA1	MUY-JP18VF-DA1	Type C	CN606
2018	MUY-JP18VF-NE1	MUY-JP18VF-NE1	Type C	CN606
2018	MUY-JP22VF-DA1	MUY-JP22VF-DA1	Type C	CN606
2018	MUY-JP24VF-NE1	MUY-JP24VF-NE1	Type C	CN606
2018	MUY-JP25VF-VN1	MUY-JP25VF-VN1	Type C	CN606
2018	MUY-JP35VF-VN1	MUY-JP35VF-VN1	Type C	CN606
2018	MUY-JP50VF-VN1	MUY-JP50VF-VN1	Type C	CN606
2018	MUY-JP60VF-VN1	MUY-JP60VF-VN1	Type C	CN606
2018	MUZ-HP13VA-DA1	MUZ-HP13VA-DA1	Type C	CN606
2018	MUZ-HP18VA-DA1	MUZ-HP18VA-DA1	Type C	CN606
2018	MUZ-HP24VA-DA1	MUZ-HP24VA-DA1	Type C	CN606
2018	MUZ-LN10VF-MY1	MUZ-LN10VF-MY1	Type C	CN606
2018	MUZ-LN13VF-MY1	MUZ-LN13VF-MY1	Type C	CN606
2018	MUZ-LN18VF-DA1	MUZ-LN18VF-DA1	Type C	CN606
2018	MUZ-LN25VF-VN1	MUZ-LN25VF-VN1	Type C	CN606
2018	MUZ-LN35VF-VN1	MUZ-LN35VF-VN1	Type C	CN606
2019	MUY-KP09VF-TH1	MUY-KP09VF-TH1	Type C	CN606
2019	MUY-KP13VF-TH1	MUY-KP13VF-TH1	Type C	CN606

fiscal_year	series	model	Relay cable	Connector
2019	MUY-KP15VF-TH1	MUY-KP15VF-TH1	Type C	CN606
2019	MUY-KP18VF-TH1	MUY-KP18VF-TH1	Type C	CN606
2019	MUY-GP10VF-SG1	MUY-GP10VF-SG1	Type C	CN606
2019	MUY-GP13VF-SG1	MUY-GP13VF-SG1	Type C	CN606
2019	MUY-GP15VF-SG1	MUY-GP15VF-SG1	Type C	CN606
2019	MUY-GP18VF-SG1	MUY-GP18VF-SG1	Type C	CN606
2019	MUY-GP20VF-SG1	MUY-GP20VF-SG1	Type C	CN606
2019	MUY-GP24VF-SG1	MUY-GP24VF-SG1	Type C	CN806
2019	MUY-GR10VF-DA1	MUY-GR10VF-DA1	Type C	CN606
2019	MUY-GR10VF-MY1	MUY-GR10VF-MY1	Type C	CN606
2019	MUY-GR13VF-DA1	MUY-GR13VF-DA1	Type C	CN606
2019	MUY-GR13VF-MY1	MUY-GR13VF-MY1	Type C	CN606
2019	MUY-GR13VFT-DA1	MUY-GR13VFT-DA1	Type C	CN606
2019	MUY-GR15VF-DA1	MUY-GR15VF-DA1	Type C	CN606
2019	MUY-GR15VF-MY1	MUY-GR15VF-MY1	Type C	CN606
2019	MUY-GR18VF-DA1	MUY-GR18VF-DA1	Type C	CN606
2019	MUY-GR18VF-MY1	MUY-GR18VF-MY1	Type C	CN606
2019	MUY-GR18VFT-DA1	MUY-GR18VFT-DA1	Type C	CN606
2019	MUY-GR22NJ-TW1	MUY-GR22NJ-TW1	Type C	CN606
2019	MUY-GR22VF-DA1	MUY-GR22VF-DA1	Type C	CN606
2019	MUY-GR22VFT-DA1	MUY-GR22VFT-DA1	Type C	CN606
2019	MUY-GR24VF-MY1	MUY-GR24VF-MY1	Type C	CN606
2019	MUY-GR25VF-VN1	MUY-GR25VF-VN1	Type C	CN606
2019	MUY-GR26VF-DA1	MUY-GR26VF-DA1	Type C	CN806
2019	MUY-GR28NJ-TW1	MUY-GR28NJ-TW1	Type C	CN606
2019	MUY-GR28VF-MY1	MUY-GR28VF-MY1	Type C	CN806
2019	MUY-GR35NJ-TW1	MUY-GR35NJ-TW1	Type C	CN606
2019	MUY-GR35VF-VN1	MUY-GR35VF-VN1	Type C	CN606
2019	MUY-GR42NJ-TW1	MUY-GR42NJ-TW1	Type C	CN606
2019	MUY-GR50NJ-TW1	MUY-GR50NJ-TW1	Type C	CN806
2019	MUY-GR50VF-VN1	MUY-GR50VF-VN1	Type C	CN606
2019	MUY-GR60NJ-TW1	MUY-GR60NJ-TW1	Type C	CN806
2019	MUY-GR60VF-VN1	MUY-GR60VF-VN1	Type C	CN606
2019	MUY-GR71NJ-TW1	MUY-GR71NJ-TW1	Type C	CN806
2019	MUY-GR71VF-VN1	MUY-GR71VF-VN1	Type C	CN606
2019	MUY-GR80NJ-TW1	MUY-GR80NJ-TW1	Type C	CN806
2019	MUY-JR22VF-DA1	MUY-JR22VF-DA1	Type C	CN606
2019	MUY-JR36VF-DA1	MUY-JR36VF-DA1	Type C	CN806
2019	MUY-JR36VF-MY1	MUY-JR36VF-MY1	Type C	CN806
2019	MUY-JS09VF-TH1	MUY-JS09VF-TH1	Type C	CN606
2019	MUY-JS13VF-TH1	MUY-JS13VF-TH1	Type C	CN606
2019	MUY-JS15VF-TH1	MUY-JS15VF-TH1	Type C	CN606
2019	MUY-JS18VF-TH1	MUY-JS18VF-TH1	Type C	CN606
2019	MUY-JS24VF-TH1	MUY-JS24VF-TH1	Type C	CN606
2019	MUY-KS09VF-TH1	MUY-KS09VF-TH1	Type C	CN606
2019	MUY-KS13VF-TH1	MUY-KS13VF-TH1	Type C	CN606
2019	MUY-KS15VF-TH1	MUY-KS15VF-TH1	Type C	CN606
2019	MUY-KS18VF-TH1	MUY-KS18VF-TH1	Type C	CN606
2019	MUY-KS24VF-TH1	MUY-KS24VF-TH1	Type C	CN606
2019	MUZ-GR22NJ-TW1	MUZ-GR22NJ-TW1	Type C	CN606
2019	MUZ-GR28NJ-TW1	MUZ-GR28NJ-TW1	Type C	CN606
2019	MUZ-GR35NJ-TW1	MUZ-GR35NJ-TW1	Type C	CN606
2019	MUZ-GR42NJ-TW1	MUZ-GR42NJ-TW1	Type C	CN606

fiscal_year	series	model	Relay cable	Connector
2019	MUZ-GR50NJ-TW1	MUZ-GR50NJ-TW1	Type C	CN806
2019	MUZ-GR60NJ-TW1	MUZ-GR60NJ-TW1	Type C	CN806
2019	MUZ-GR71NJ-TW1	MUZ-GR71NJ-TW1	Type C	CN806
2019	MUZ-GR80NJ-TW1	MUZ-GR80NJ-TW1	Type C	CN806
2019	SUZ-KA25VA-VN.TH	SUZ-KA25VA-VN.TH	Type C	CN606
2019	SUZ-KA35VA-VN.TH	SUZ-KA35VA-VN.TH	Type C	CN606
2019	SUZ-KA50VA-DA.TH	SUZ-KA50VA-DA.TH	Type C	CN606
2019	SUZ-KA50VA-VN.TH	SUZ-KA50VA-VN.TH	Type C	CN606
2019	SUZ-KA71VA-DA.TH	SUZ-KA71VA-DA.TH	Type C	CN806
2019	SUZ-KA71VA-VN.TH	SUZ-KA71VA-VN.TH	Type C	CN806
2020	MUY-HS22NF-TW1	MUY-HS22NF-TW1	Type C	CN606
2020	MUY-HS28NF-TW1	MUY-HS28NF-TW1	Type C	CN606
2020	MUY-HS35NF-TW1	MUY-HS35NF-TW1	Type C	CN606
2020	MUY-HS42NF-TW1	MUY-HS42NF-TW1	Type C	CN606
2020	MUY-HS50NF-TW1	MUY-HS50NF-TW1	Type C	CN606
2020	MUY-HS60NF-TW1	MUY-HS60NF-TW1	Type C	CN606
2020	MUY-HS71NF-TW1	MUY-HS71NF-TW1	Type C	CN806
2020	MUY-HS80NF-TW1	MUY-HS80NF-TW1	Type C	CN806
2020	MUY-HS90NF-TW1	MUY-HS90NF-TW1	Type C	CN806
2020	MUY-JP10VF2-MY1	MUY-JP10VF2-MY1	Type C	CN606
2020	MUY-JP10VF-MY1	MUY-JP10VF-MY1	Type C	CN606
2020	MUY-JP13VF-MY1	MUY-JP13VF-MY1	Type C	CN606
2020	MUY-JP15VF-MY1	MUY-JP15VF-MY1	Type C	CN606
2020	MUY-JP18VF-MY1	MUY-JP18VF-MY1	Type C	CN606
2020	MUY-JP24VF-MY1	MUY-JP24VF-MY1	Type C	CN606
2020	MUY-JR30VF-DA1	MUY-JR30VF-DA1	Type C	CN806
2020	MUY-JR34VF-TH1	MUY-JR34VF-TH1	Type C	CN806
2020	MUY-JS18VF-DA1	MUY-JS18VF-DA1	Type C	CN606
2020	MUY-JS18VF-MY1	MUY-JS18VF-MY1	Type C	CN606
2020	MUY-JS22VF-DA1	MUY-JS22VF-DA1	Type C	CN606
2020	MUY-JS24VF-MY1	MUY-JS24VF-MY1	Type C	CN606

Maintenance Tool for .NET

© 2010 (2023) MITSUBISHI ELECTRIC CORPORATION ALL RIGHTS RESERVED.

DotNetZip

Version 1.9.1.5

Microsoft Public License (Ms-PL)

Copyright © Dino Chiesa 2006 - 2010.

Maintenance Tool for .NET contains software that is based on the Microsoft Public License (Ms-PL) and other licenses.

These open source components are provided "as is" without warranty of any kind, including, but not limited to the implied warranties of merchantability and fitness for a particular purpose.

Distributed DotNetZip library according to Microsoft Public License (Ms-PL) is used for data export and import in the Maintenance Tool.

The DotNetZip source code is available at <http://dotnetzip.codeplex.com/>.

Microsoft Public License (Ms-PL)

This license governs use of the accompanying software. If you use the software, you accept this license. If you do not accept the license, do not use the software.

1. Definitions

The terms "reproduce," "reproduction," "derivative works," and "distribution" have the same meaning here as under U.S. copyright law.

A "contribution" is the original software, or any additions or changes to the software.

A "contributor" is any person that distributes its contribution under this license.

"Licensed patents" are a contributor's patent claims that read directly on its contribution.

2. Grant of Rights

(A) Copyright Grant- Subject to the terms of this license, including the license conditions and limitations in section 3, each contributor grants you a non-exclusive, worldwide, royalty-free copyright license to reproduce its contribution, prepare derivative works of its contribution, and distribute its contribution or any derivative works that you create.

(B) Patent Grant- Subject to the terms of this license, including the license conditions and limitations in section 3, each contributor grants you a non-exclusive, worldwide, royalty-free license under its licensed patents to make, have made, use, sell, offer for sale, import, and/or otherwise dispose of its contribution in the software or derivative works of the contribution in the software.

3. Conditions and Limitations

(A) No Trademark License- This license does not grant you rights to use any contributors' name, logo, or trademarks.

(B) If you bring a patent claim against any contributor over patents that you claim are infringed by the software, your patent license from such contributor to the software ends automatically.

(C) If you distribute any portion of the software, you must retain all copyright, patent, trademark, and attribution notices that are present in the software.

(D) If you distribute any portion of the software in source code form, you may do so only under this license by including a complete copy of this license with your distribution. If you distribute any portion of the software in compiled or object code form, you may only do so under a license that complies with this license.

(E) The software is licensed "as-is." You bear the risk of using it. The contributors give no express warranties, guarantees, or conditions. You may have additional consumer rights under your local laws which this license cannot change. To the extent permitted under your local laws, the contributors exclude the implied warranties of merchantability, fitness for a particular purpose and non-infringement.

• MS, Microsoft, Microsoft logo, and Windows are registered trademarks and trade names of Microsoft Corporation. Each company may use as registered trademarks and trade names the product names used in this manual.